

User Manual



Solar Hybrid Inverter

HESP4840U120-HUS | HESP4850U120-HUS
HESP4860U140-HUS | HESP4865U140-HUS

CONTENTS

1. Safety Precautions	1
1.1 How to Use This Instruction Manual	1
1.2 Symbols in this manual	1
1.3 Safety Instructions	1
2. Product Introduction	2
2.1 Product Description	2
2.2 Product Features	2
2.3 System Connection Diagram	3
2.4 Product Overview	6
2.5 Product Size	7
3. Installation	8
3.1 Parts List	8
3.2 Mounting Instructions	9
4. Connection Instructions	11
4.1 Split-Phase or Split-Phase Mode	11
4.2 Cable & Circuit Breaker Requirement	12
4.3 GRID & LOAD & Generator Connection	14
4.4 Battery Connection	15
4.5 PV Connection	15
4.6 Dry Contact Connection	17
4.7 Grounding Connection	18
4.8 Final Installation	18
4.9 Parallel Connection	18
5. Operation	29
5.1 Operation and Display Panel	29
5.2 Setting Parameters	32
5.3 Time-slot Charging and Discharging Function	43
5.4 Battery Parameters	44
6. Communication	45
6.1 Product Overview	45
6.2 RS485/CAN Communication Function	45
6.3 CAN Function	46
6.4 Dry Contact Function	46
6.5 WiFi Communication Function	47
6.6 USB-1 Communication Function	48
6.7 USB-2 Display Port	48
6.8 DRM(Only Australia)	48
6.9 Parallel Communication Function	49
6.10 External CT Wiring	49
7. Fault Codes and Countermeasures	51
7.1 Fault Codes	51
7.2 Partial Troubleshooting	53
8. Protection and Maintenance	54
8.1 Protection Functions	54
8.2 Maintenance	55
9. Datasheet	56





1. Safety Precautions

1.1 How to Use This Instruction Manual

The manual mainly describes the product information, installation guidelines, operation instructions, maintenance instructions for the HESP4840U120-HUS, HESP4850U120-HUS, HESP4860U140-HUS, HESP4865U140-HUS.

Read the manual and other related documents before performing any operation on the inverter. Documents must be stored carefully and be available at all times.

1.2 Symbols in this manual

 DANGER	DANGER indicates a hazardous situations which if not avoided will result in death or serious injury.
 WARNING	WARNING indicates a hazardous situations which if not avoided could result in death or serious injury.
 CAUTION	CAUTION indicates a hazardous situations which if not avoided could result in minor or moderate injury.
 NOTICE	NOTICE provide some tips on operation of products.

1.3 Safety Instructions

WARNING: This chapter contains important safety and operating instructions. Read and keep this manual for future reference.

- Be sure to comply the local requirements and regulation to install this inverter.
- Beware of high voltage. Please turn off the switch of each power sources before and during the installation to avoid electric shock.
- For optimum operation of this inverter, please follow required specification to select appropriate cable size and necessary protective device.
- Do not connect or disconnect any connections when the inverter is working.
- Do not open the terminal cover when the inverter working.
- Make sure the inverter is well grounding.
- Never cause AC output and DC input short circuited.
- Do not disassembly this unit, for all repair and maintenance, please take it to the professional service center.
- Never charge a frozen battery.
- Please keep children away from touching or mishandling the inverter.
- Please make sure that this inverter is the only input power source for the load, do not use it in parallel with other input AC power sources to avoid damage. Ensure this inverter is the sole input power source for the load. Do not parallel it with other AC input power sources to avoid damage.

2. Product Introduction

2.1 Product Description

The HESP series is a new type of photovoltaic energy storage inverter integrating photovoltaic and grid charging functions, with AC sine wave output. It adopts DSP control and advanced control algorithms, featuring high response speed, high reliability, and industrial-grade standards.

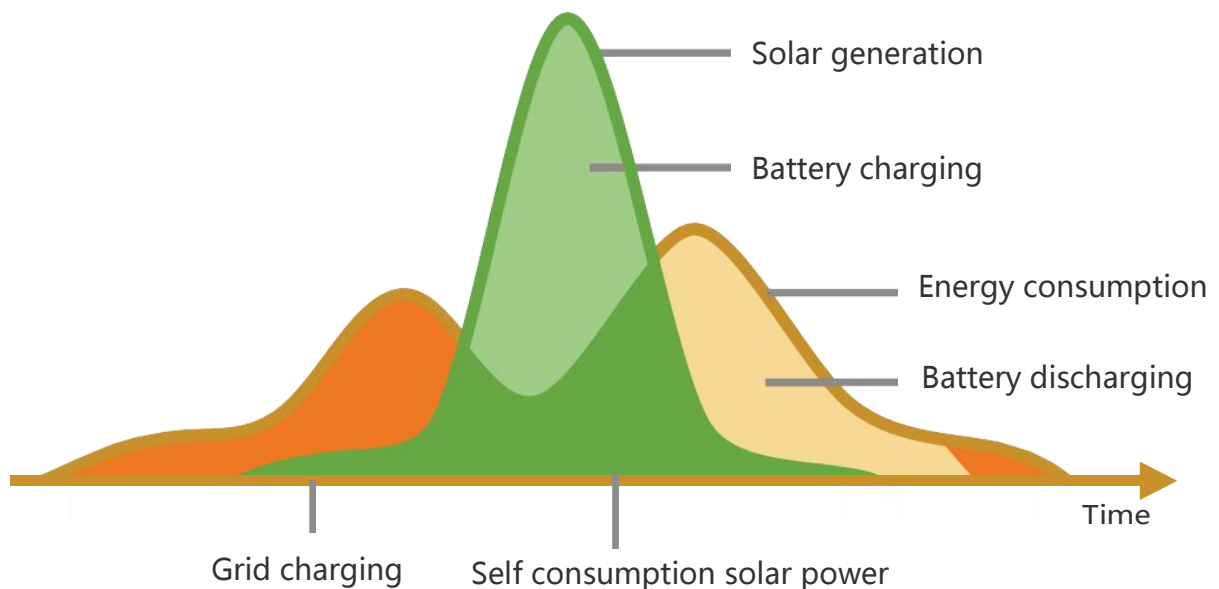

2.2 Product Features

- Supports connection to various types of energy storage batteries, including lead-acid batteries and lithium-ion batteries.
- With a dual activation function when the li-ion battery is dormant; either mains/ photovoltaic power supply access can trigger the activation of the li-ion battery.
- Supports split-phase pure sine wave output of 200-254V.
- Supports phase voltage adjustment within the range of 100, 105, 110, 120, and 127Vac.
- Dual MPPT with 99.9% efficiency and maximum 32A current in a split circuit, perfectly adapted to high power modules.
- 2 charging modes are available: solar only, mixed mains/PV charging.
- With the time-slot charging and discharging setting function, you can set the time period for cutting in/out of mains charging and switch the time period between battery discharging and mains bypass power supply mode.
- Energy saving mode function to reduce no-load energy losses.
- With two output modes of utility bypass and inverter output, with uninterrupted power supply function.
- LCD large screen dynamic flow diagram design, easy to understand the system data and operation status.

- 360° protection with complete short circuit protection, over current protection, over under voltage protection, overload protection, backfill protection, etc.
- Supports split-phase unbalanced output
- Support CAN, USB, and RS485 communication.

2.3 System Connection Diagram

The diagram below shows the system application scenario of this product. A complete system consists of the following components:

- **PV Modules:** Converts light energy into DC energy, which can be used to charge the battery via an inverter or directly inverted into AC power to supply the load.
- **Grid:** Connected to the mains AC input, supplying power to loads while charging batteries. The system can operate off-grid when batteries and PV modules power the loads.
- **Battery:** The role of the battery is to ensure the normal power supply of the system loads in case of insufficient photovoltaic and no utility power.
- **Home Load:** Connects to a variety of home and office loads including refrigerators, lamps, TVs, fans, air conditioners and other AC loads.
- **Generator/Secondary Load/Micro-Inverter Input:** When connected to an AC generator, supplies power to loads and charges batteries simultaneously. Without generator connection, this interface can be configured as a secondary load output to power loads. When connected to micro-inverters, it supplies power to loads and charges batteries concurrently.
- **Inverter:** It is the energy conversion device of the whole system.

Note: The actual application scenario determines the specific system wiring method.

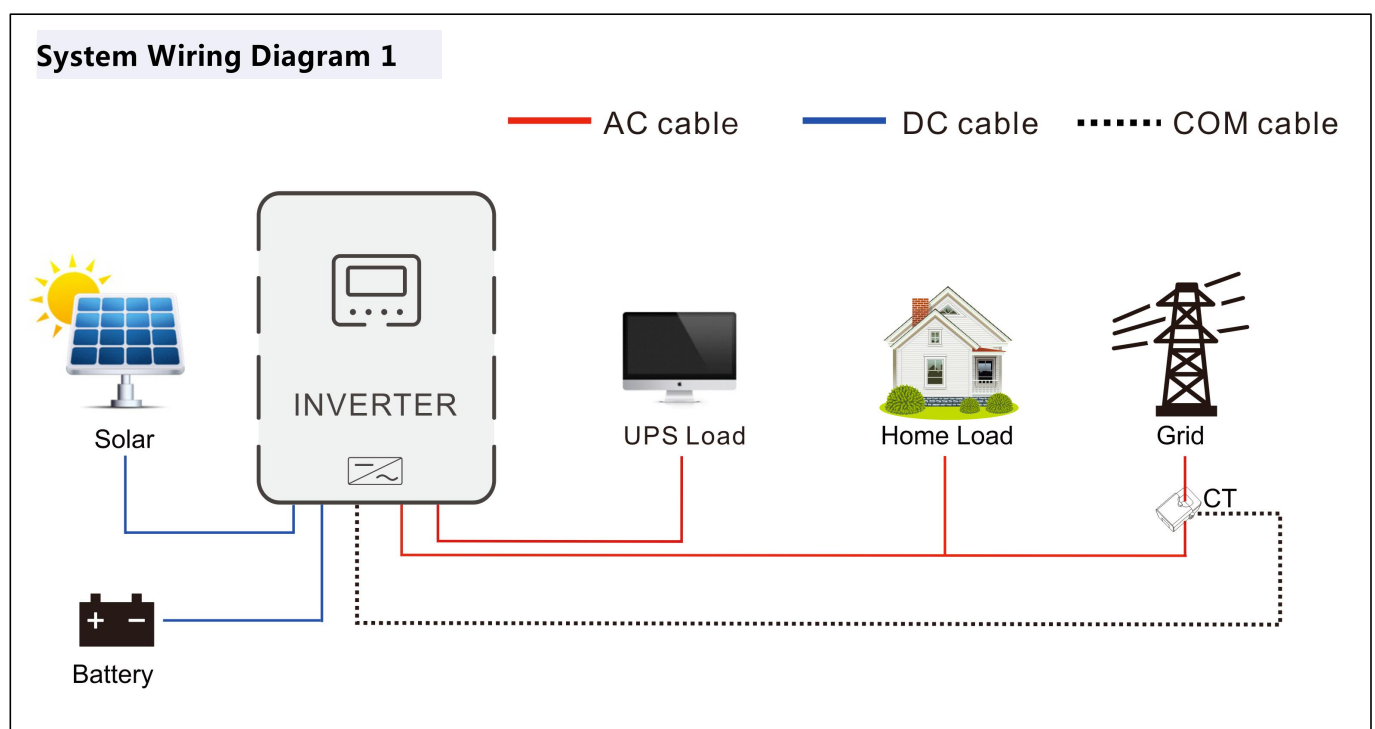

System Wiring Diagram 2

— AC cable — DC cable COM cable

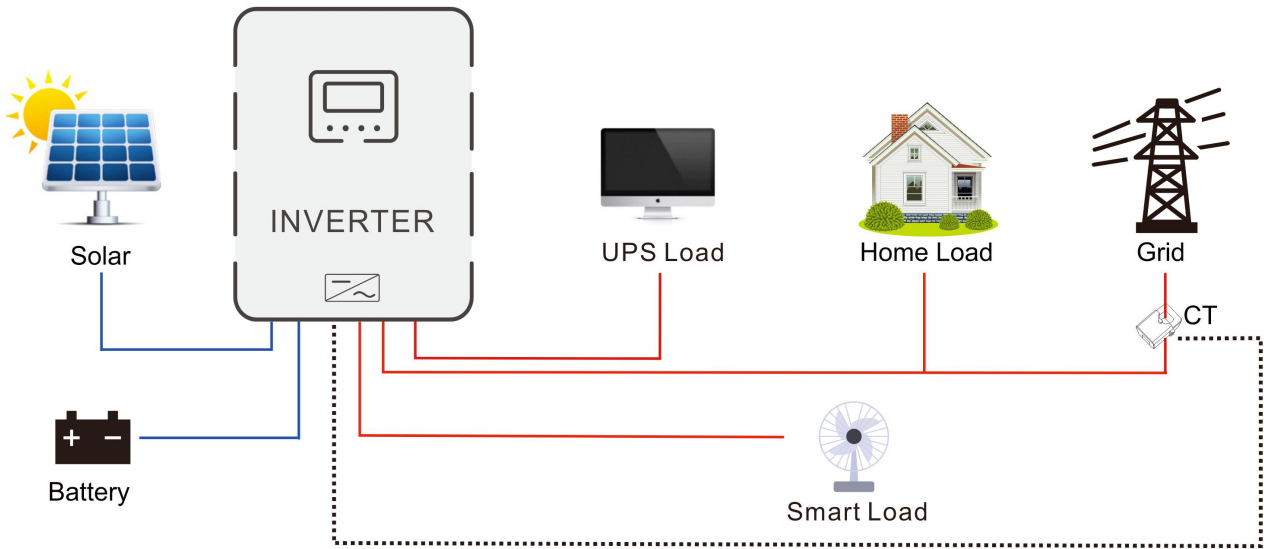

System Wiring Diagram 3

— AC cable — DC cable COM cable

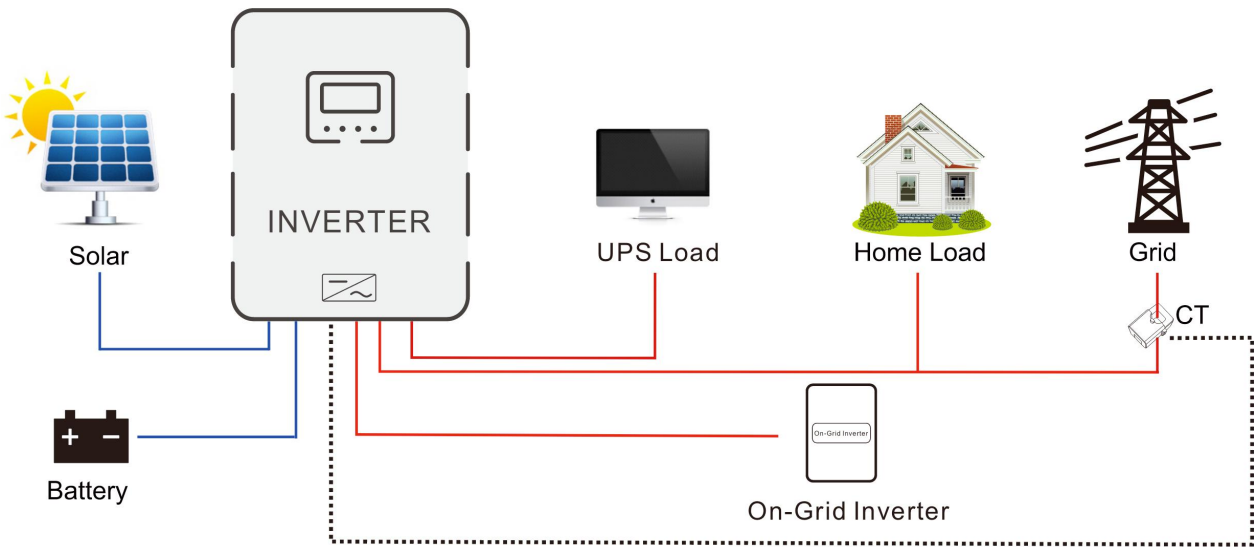

System Wiring Diagram 4

On-Grid+AC coupling

— AC cable — DC cable COM cable

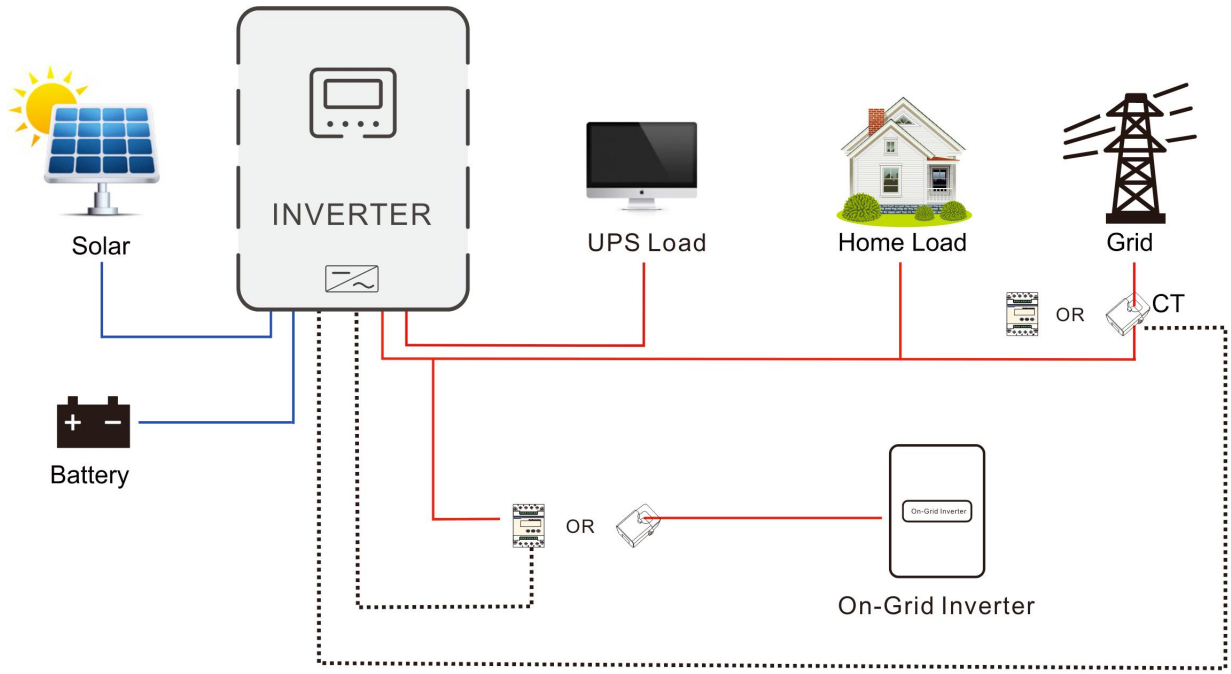

System Wiring Diagram 5

On-Grid+AC coupling

— AC cable — DC cable COM cable

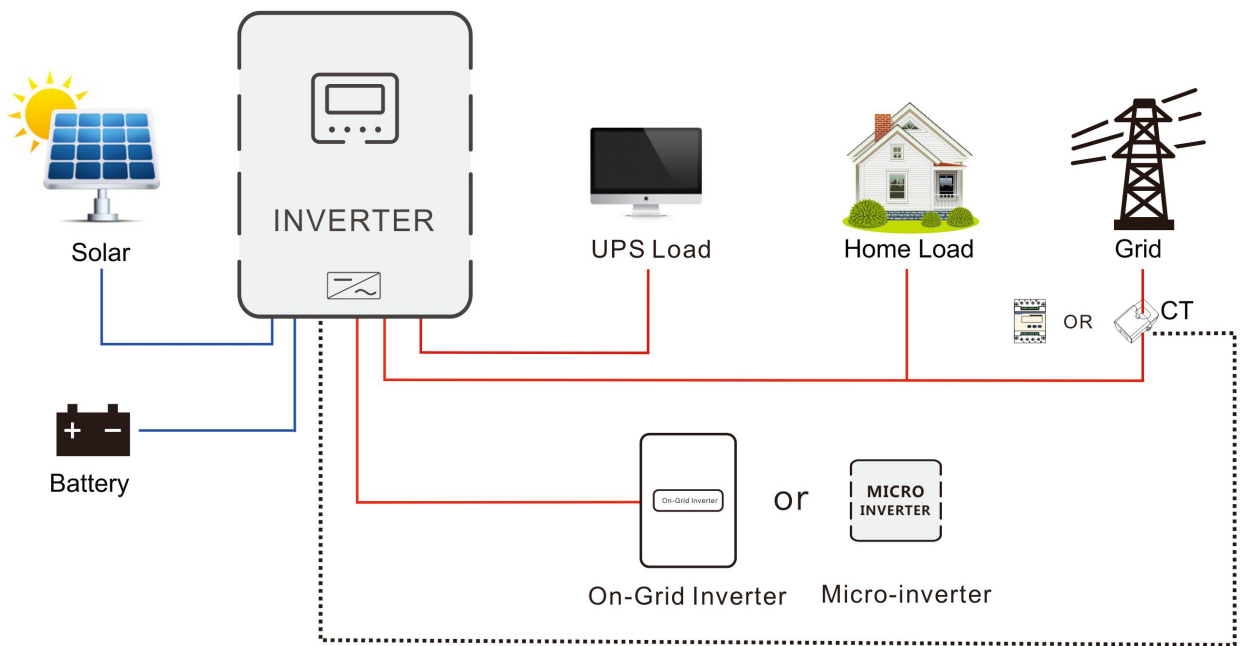

2.4 Product Overview

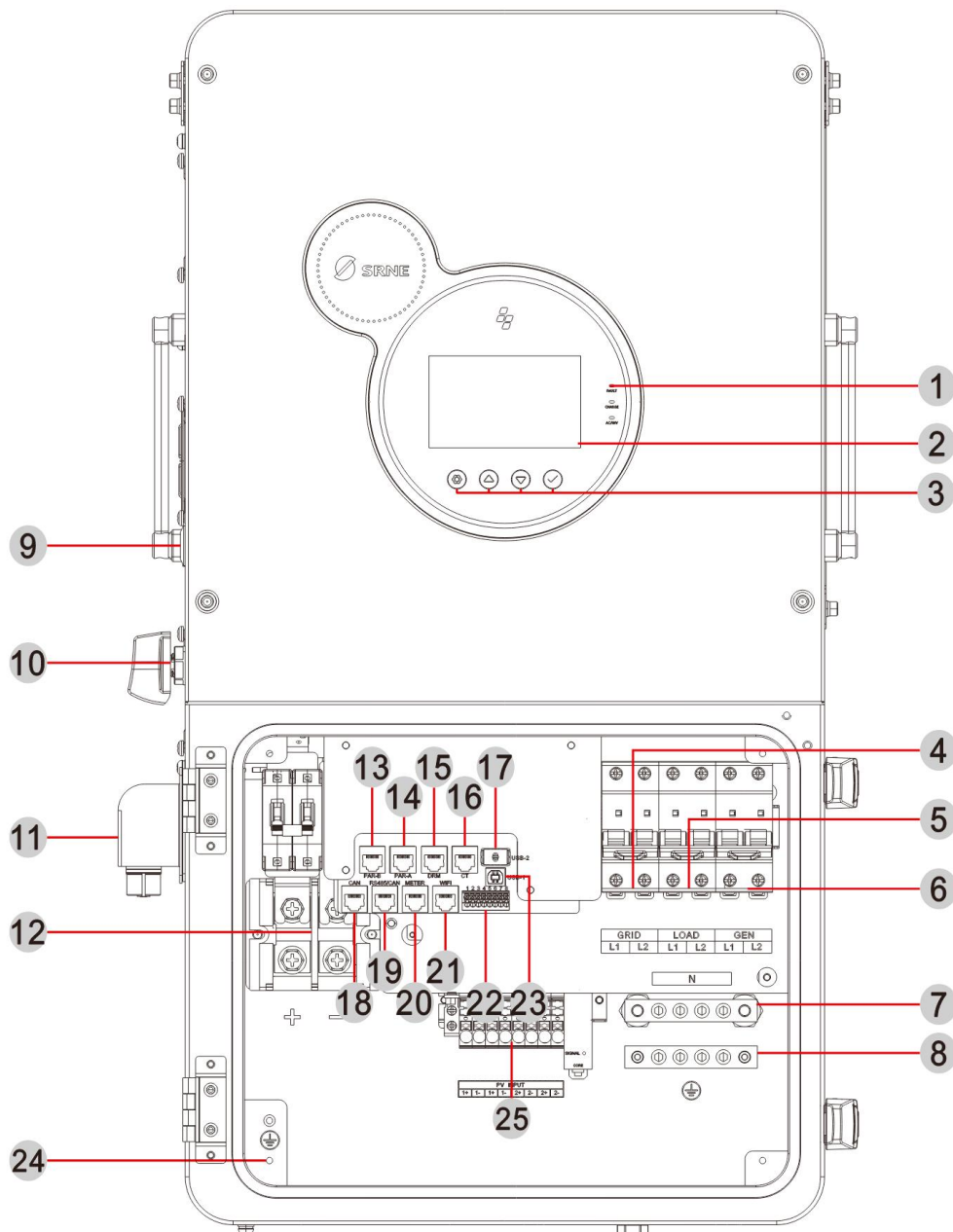

1	LED Indicator Light	2	LCD Screen	3	Physical Buttons
4	Grid Input (L1+L2) + Circuit Breaker	5	Load Output (L1+L2) + Circuit Breaker	6	Generator Input (L1+L2) + Circuit Breaker
7	Grid/Load/Generator Neutral	8	Ground Terminal	9	ON/OFF
10	PV Circuit Breaker	11	DRM Port	12	Battery Connection Screws
13	Paralle B	14	Paralle A	15	DRM Port
16	CT Port	17	USB-2 Display Port	18	CAN Port
19	RS485/ CAN Port	20	Electricity Meter Port	21	WiFi Port
22	Dry Contact Interface	23	USB-1 Communication Port	24	Machine Ground Wire Interface
25	PV Port				



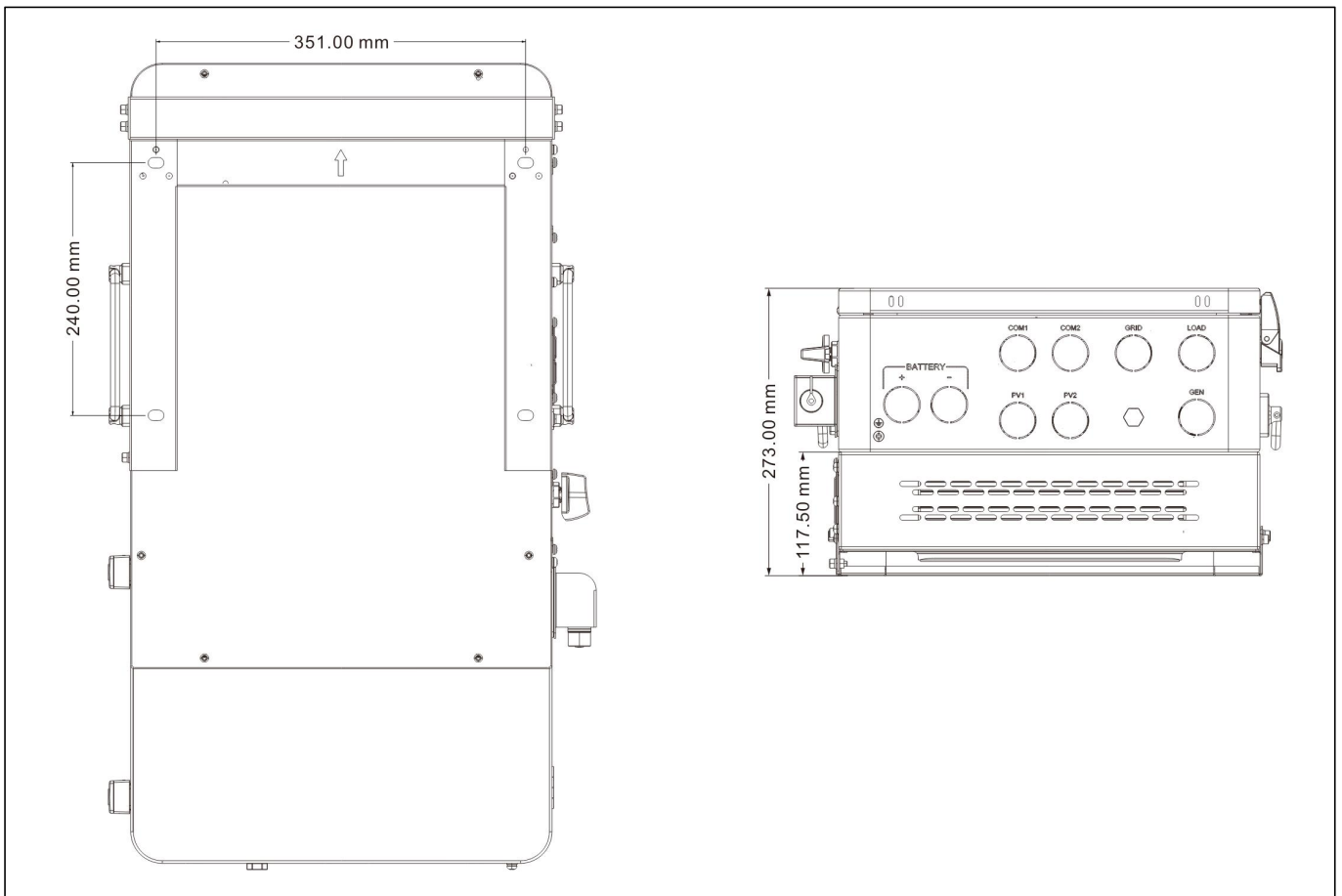
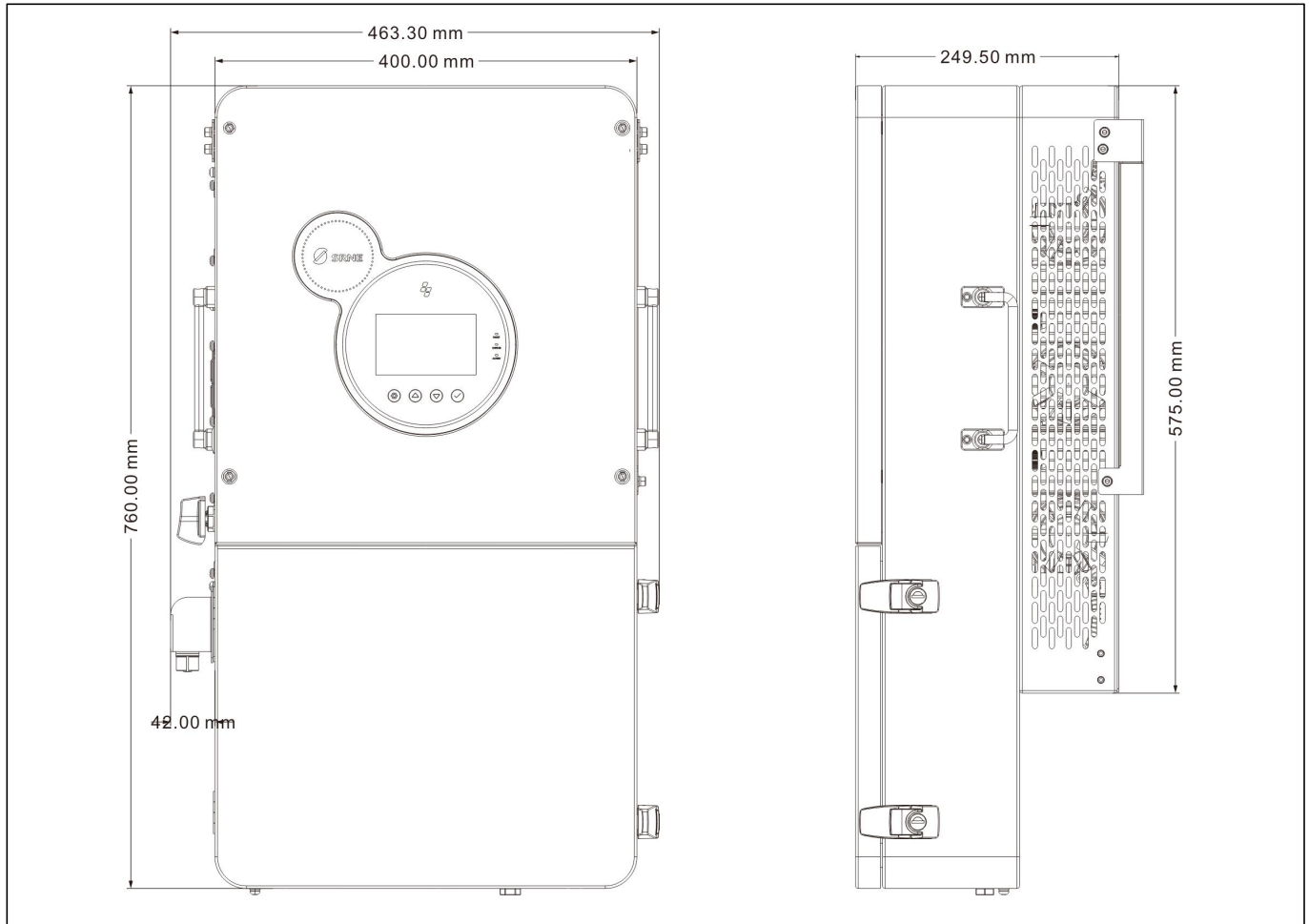





2.5 Product Size

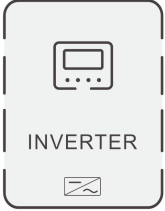
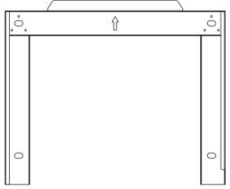
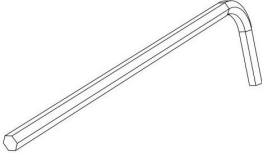
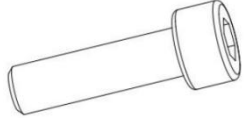

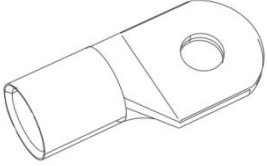
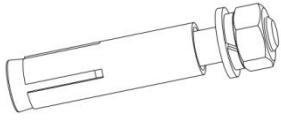
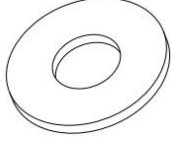
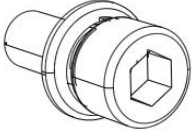
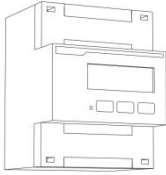
3. Installation

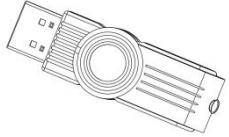
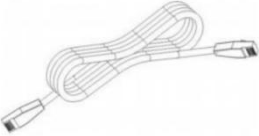
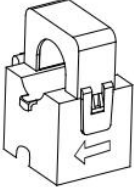
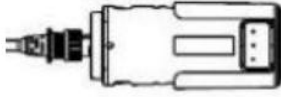
3.1 Parts List

Please check the equipment before installation. Make sure that there is no damage to the packaging. You should have received the following items in the package:

 <p>Inverter x 1pcs</p>	 <p>Wall mount bracket x 1pcs</p>	 <p>Hex Key_L-Type_5mm/ Hex Key_L-Type_8mm x 1pcs / x 1pcs</p>	 <p>Spare screw M5*12mm / M6*18mm x 2pcs / 1pcs</p>
 <p>M8 socket x 1pcs</p>	 <p>Crimp Terminal SC70-10 x 2pcs</p>	 <p>Expansion bolt M8*60mm x 4pcs</p>	 <p>M8 flat washer x 4pcs</p>
 <p>Socket cap screw M5*12 (triple combination) x 2 pcs</p>	 <p>Three-phase meter (Optional) x 1pcs</p>	 <p>Keys x 4pcs</p>	 <p>USB Flash Drive x 1pcs</p>
 <p>Parallel connection cable x 1pcs</p>	 <p>CT x 1pcs</p>	 <p>WiFi module x 1pcs</p>	 <p>User manual x 1pcs</p>
 <p>Quality certificate x 1pcs</p>	 <p>Outgoing inspection report / Warranty Card x 1pcs / x 1pcs</p>		

3.2 Mounting Instructions

3.2.1 Installation Location Selection

The HESP inverter can be used outdoors (protection class IP65). Please consider the followings before selecting the location :

- Choose the solid wall to install the inverter.
- Mount the inverter at eye level.
- Adequate heat dissipation space must be provided for the inverter.
- The ambient temperature should be between $-40^{\circ}\text{C} \sim 60^{\circ}\text{C}$ ($-40^{\circ}\text{F} \sim 140^{\circ}\text{F}$) to ensure optimal operation.

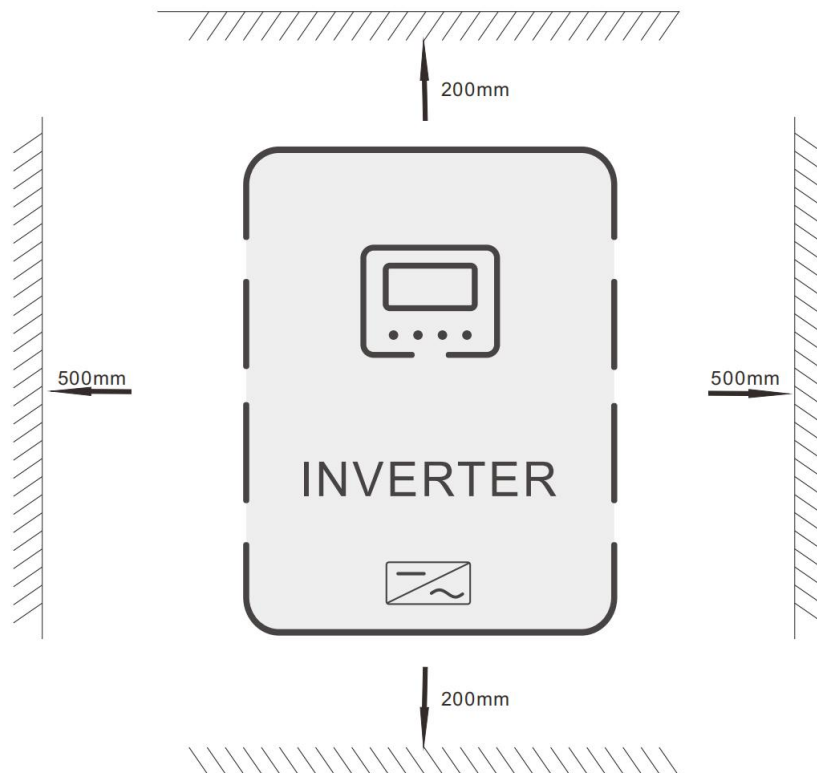

DANGER

- Do not install the inverter where highly flammable materials are near by.
- Do not install the inverter in potential explosive areas.
- Do not install the inverter with lead-acid batteries in a confined space.

CAUTION

- Do not install the inverter in direct sunlight.
- Do not install or use the inverter in a humid environment.

3.2.2 Mounting the Inverter

- **Step 1:** Determine the positions for drilling holes, ensure the position of holes are level, then mark them with a marker pen, use the hammer drill to drill holes on the wall. Keep the hammer drill perpendicular to the wall, do not shake when drilling, so as not to damage the wall. If the error of the hole is too big, you need to reposition.
- **Step 2:** Insert M8*60 expansion bolt vertically into the hole and pay attention to the insertion depth of the expanding bolt (should be deep enough)
- **Step 3:** Align the wall hanger with the position of holes, fix the wall hanger on the wall by tightening the expansion bolt with nuts.
- **Step 4:** Hang the inverter on the wall hanger first, and then fix the inverter and the wall hanger with M5 hexagon socket screws.

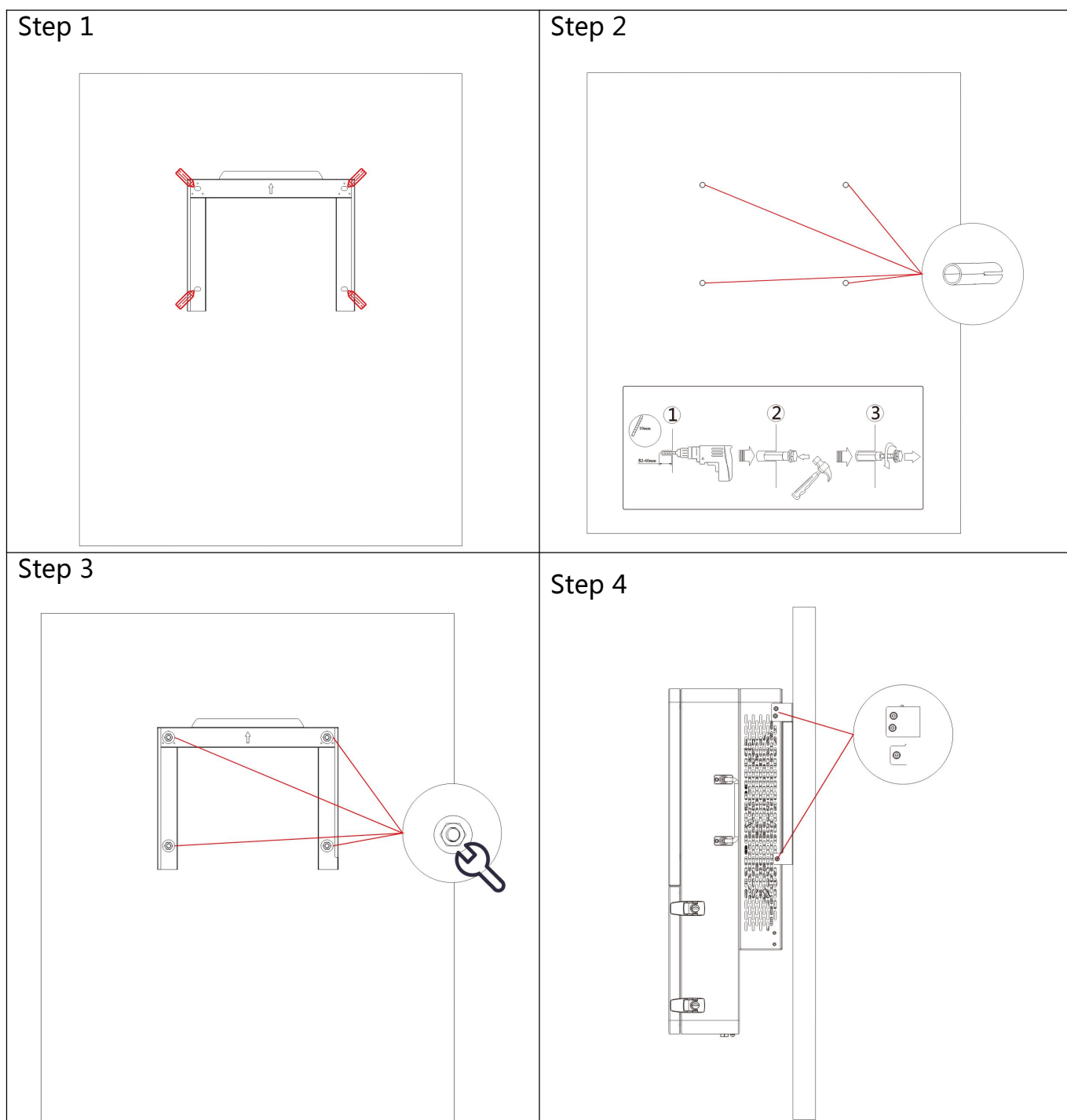

3.2.3 Removing the Terminal Protection Cover

Use the key to unlock the tower latch, and the protective cover will open.

Removable fan cover for cleaning

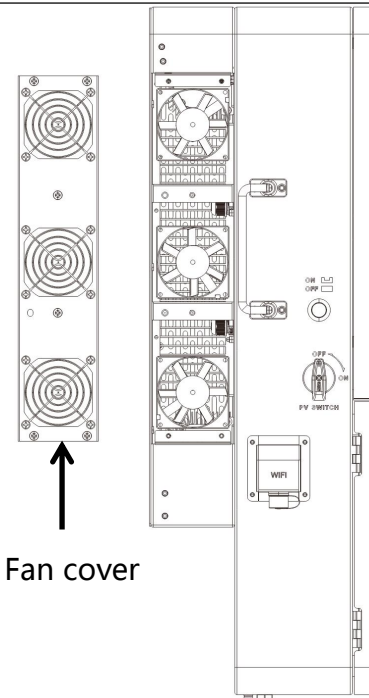
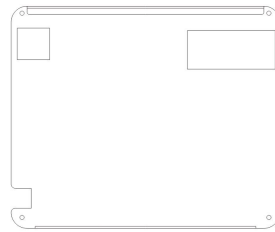
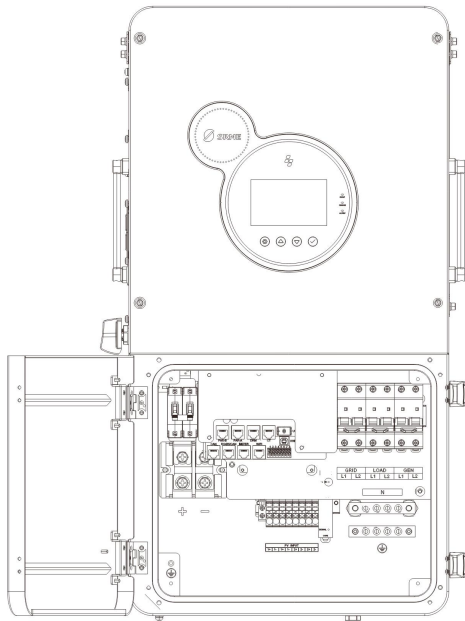

NOTICE

In areas with poor air quality, the fan cover of the device is prone to blockage by air particles. Regularly disassemble and clean the fan to prevent reduced internal air flow in the inverter, which may trigger over-temperature protection faults (Fault 19/20), affecting power supply usage and the inverter's service life.

4. Connection Instructions

4.1 Split-Phase or Split-Phase Mode

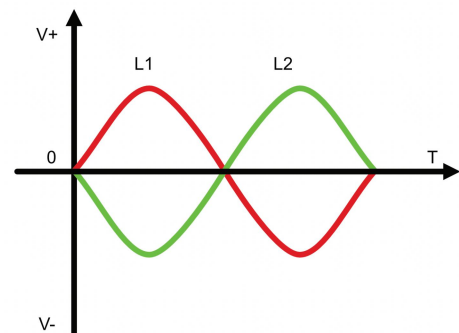
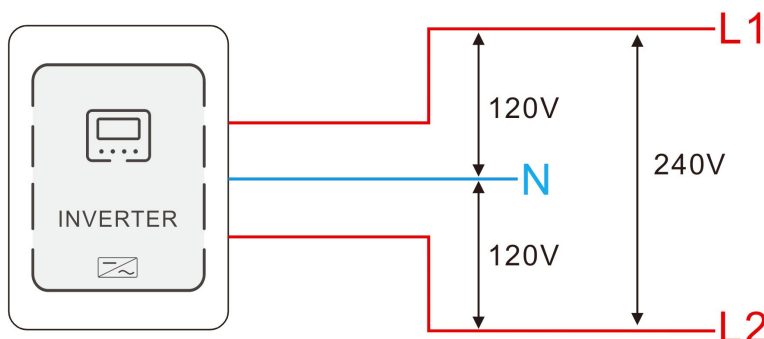

Items	Description
Applicable model	HESP series HUS model
AC output phase voltage (L-N)	100-120Vac, 120Vac default
AC output line voltage (L1-L2)	200-240Vac, 240Vac default

4.2 Cable & Circuit Breaker Requirement





■ PV Input

Models	Circuit Count	Cable Diameter	Max. Input Current	Circuit Breaker Spec
HESP4840U120-HUS	PV1-1	4mm ² / 12 AWG	16A	4P-25A
HESP4850U120-HUS	PV1-2	4mm ² / 12 AWG	16A	
HESP4860U140-HUS	PV2-1	4mm ² / 12 AWG	16A	4P-25A
HESP4865U140-HUS	PV2-2	4mm ² / 12 AWG	16A	





■ Battery

Models	Cable Diameter	Max. Input Current	Circuit Breaker Spec
HESP4840U120-HUS	43mm ² / 1 AWG	120A	2P-200A
HESP4850U120-HUS	43mm ² / 1 AWG	120A	2P-200A
HESP4860U140-HUS	43mm ² / 1 AWG	140A	2P-200A
HESP4865U140-HUS	43mm ² / 1 AWG	140A	2P-200A





■ Grid

Models	Schema	Cable Diameter	Max. Input Current	Circuit Breaker Spec
HESP4840U120-HUS		14mm ² /6AWG(L1/L2/N)	60A	3P-100A
HESP4850U120-HUS		14mm ² /6AWG(L1/L2/N)	60A	3P-100A
HESP4860U140-HUS		14mm ² /6AWG(L1/L2/N)	60A	3P-100A
HESP4865U140-HUS		14mm ² /6AWG(L1/L2/N)	60A	3P-100A

■ Generator

Models	Schema	Cable Diameter	Max. Input Current	Circuit Breaker Spec
HESP4840U120-HUS		14mm ² /6AWG(L1/L2/N)	60A	3P-100A
HESP4850U120-HUS		14mm ² /6AWG(L1/L2/N)	60A	3P-100A
HESP4860U140-HUS		14mm ² /6AWG(L1/L2/N)	60A	3P-100A
HESP4865U140-HUS		14mm ² /6AWG(L1/L2/N)	60A	3P-100A

■ Load

Models	Schema	Cable Diameter	Max. Input Current	Circuit Breaker Spec
HESP4840U120-HUS		14mm ² /6AWG(L1/L2/N)	60A	3P-100A
HESP4850U120-HUS		14mm ² /6AWG(L1/L2/N)	60A	3P-100A
HESP4860U140-HUS		14mm ² /6AWG(L1/L2/N)	60A	3P-100A
HESP4865U140-HUS		14mm ² /6AWG(L1/L2/N)	60A	3P-100A

NOTICE

● PV input, AC input, and AC output, Generator:

1. Use a stripper to remove the 6~8mm insulation of the cable.
2. Fixing a ferrule at the end of the cable. (ferrule needs to be prepared by the user)

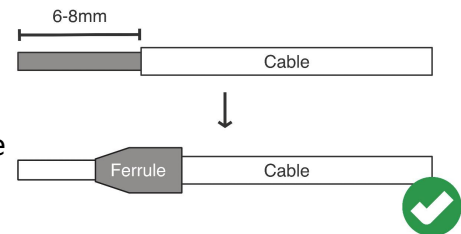

● Battery connections:

1. Use a stripper to remove the 6~8mm insulation of the cable
2. Fixing cable lugs that supply with the box at the end of the cable.

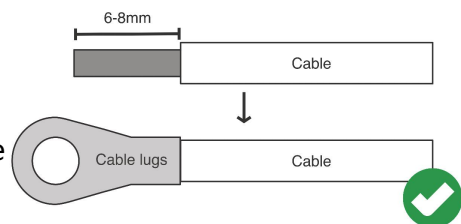

The wire diameter is for reference only. If the distance between the PV array and the inverter or between the inverter and the battery is long, using a thicker wire will reduce the voltage drop and improve the performance of the system.

4.3 GRID & LOAD & Generator Connection

Connect the live, neutral and ground wires according to the cables' position and order shown in the diagram below.

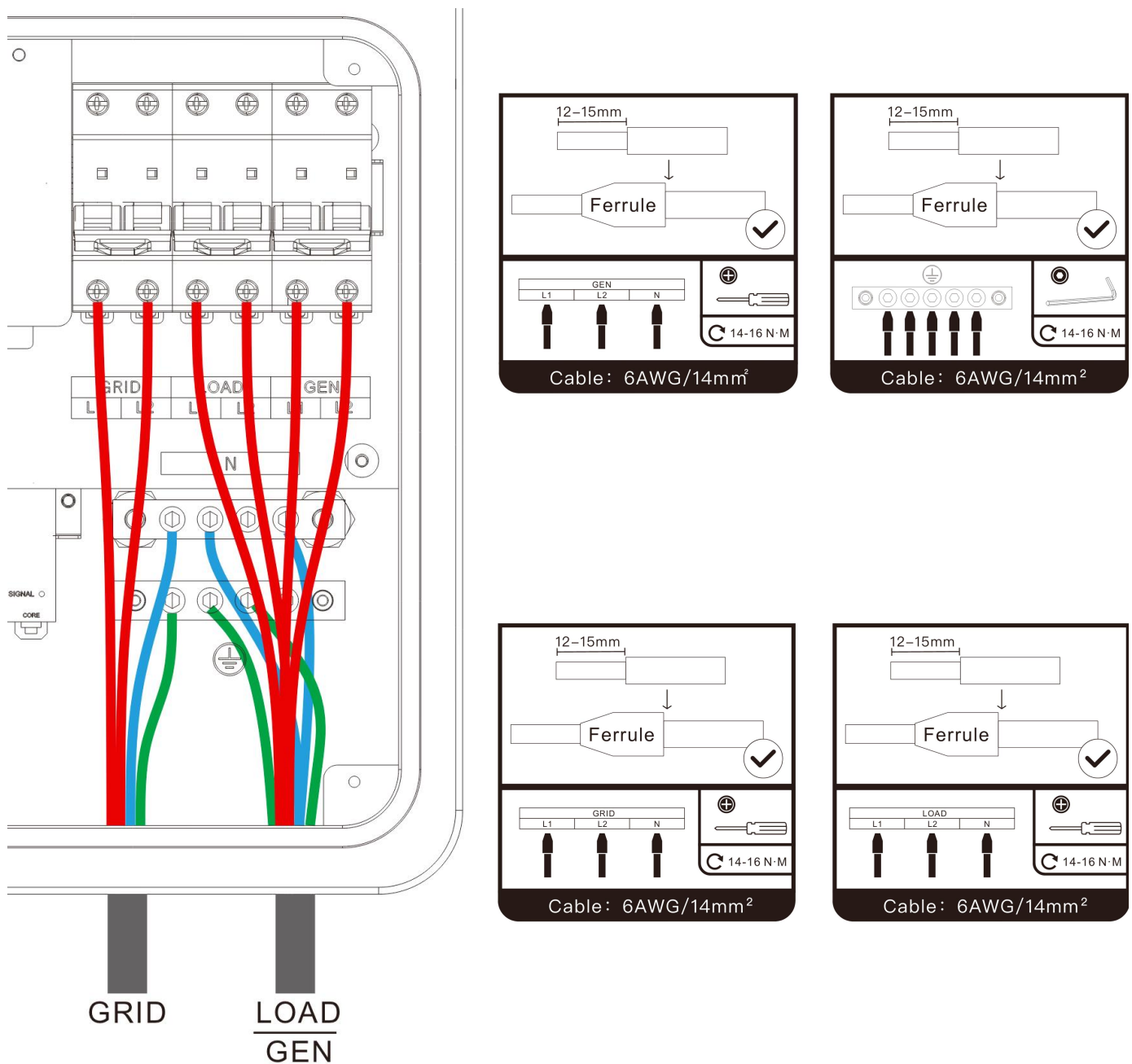

DANGER

- Before connecting AC input and output, the circuit breaker must be turned off to avoid electric shock hazards, and never operate with electricity.
- Please check that the cable used is sufficient for the requirements, too thin, poor quality cables are a serious safety hazard.

4.4 Battery Connection

Connect the positive and negative cable of the battery according to the diagram below.

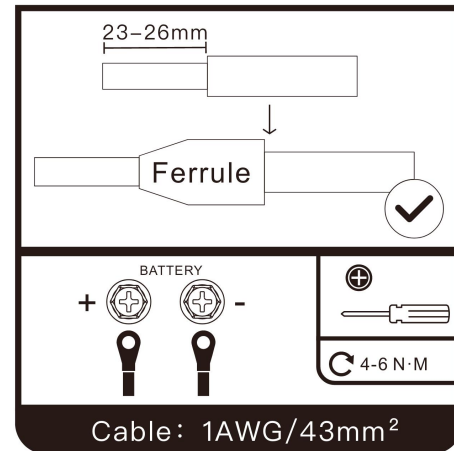
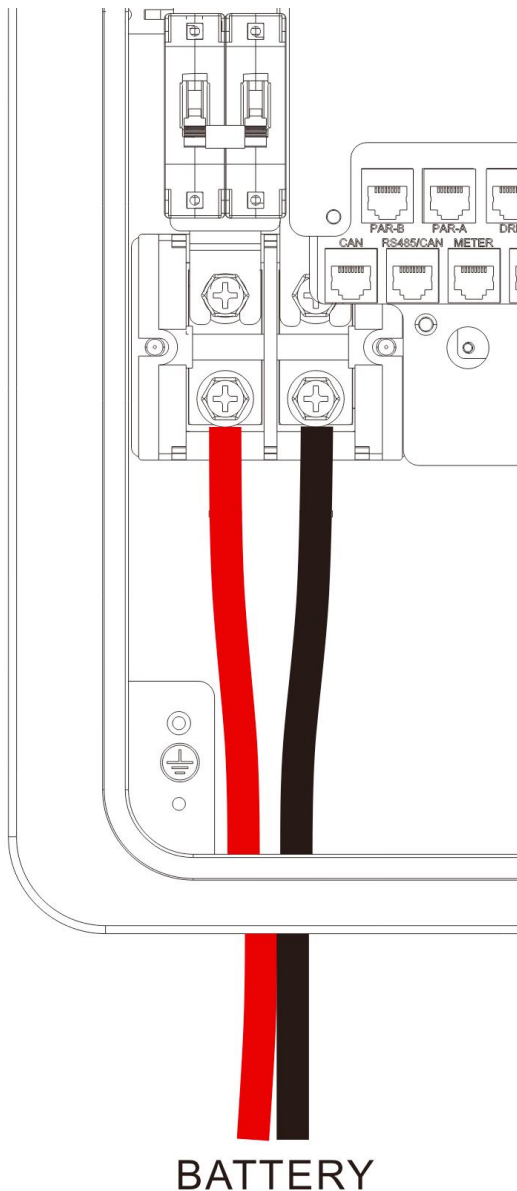

⚠ DANGER

- Before connecting battery, the circuit breaker must be turned off to avoid electric shock hazards, and never operate with electricity.
- Make sure that the positive and negative terminals of the battery are connected correctly, reversed polarity connection on battery will damage the inverter.
- Please check that the cable used is sufficient for the requirements, too thin, poor quality cables are a serious safety hazard.

4.5 PV Connection

1. Before connecting PV, first close the external circuit breaker and make sure that the cable used is sufficiently thick. Please refer to section "4.2 Cable & Circuit Breaker Selection".

2. According to the cable sequence and terminal positions shown in the figure below, correctly connect the PV input wires. When using in parallel, different units must be connected to different PV arrays or PV sources.

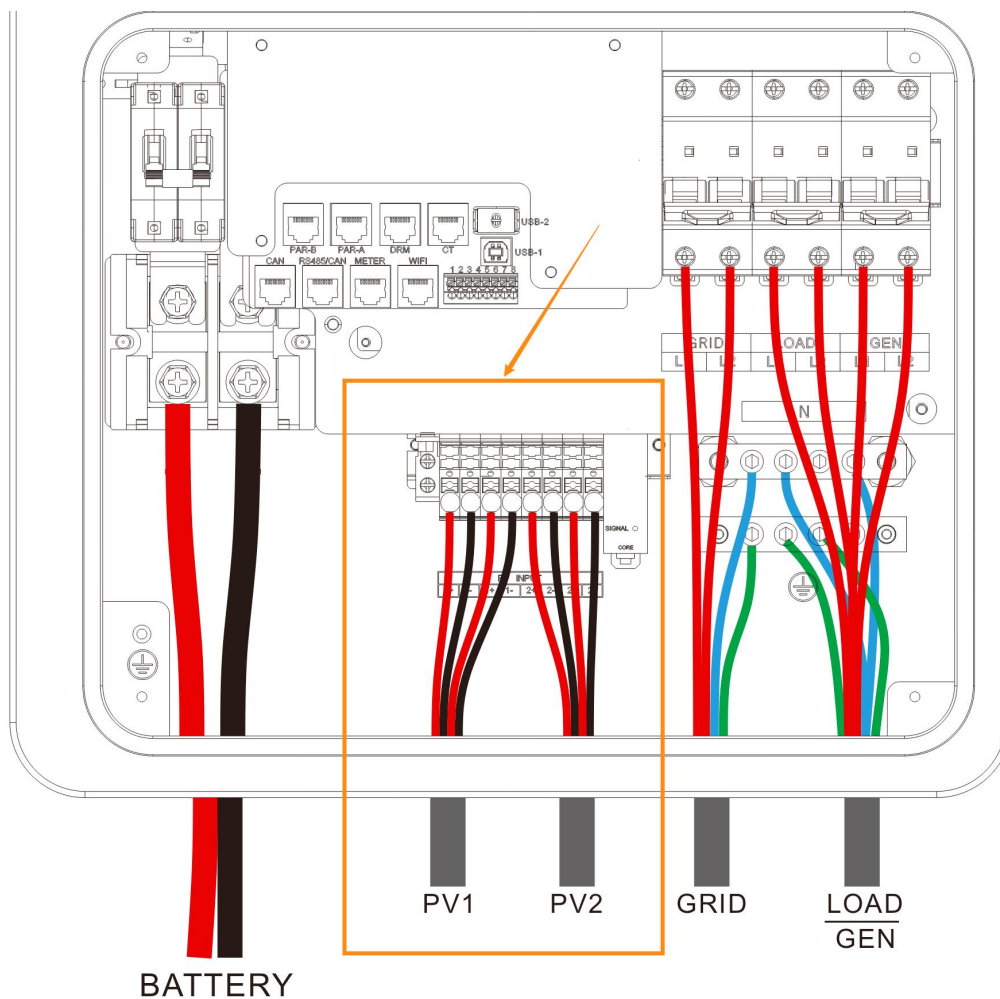

⚠ DANGER

- Before connecting the PV, the circuit breaker must be turned off to avoid electric shock hazards, and never operate with electricity.
- Make sure that the open-circuit voltage of the PV modules connected in series does not exceed the maximum open-circuit voltage of the inverter (the value is 600V), otherwise the inverter may be damaged.

Transmitter-PLC Device(Customer Optional)

The inverter includes a rapid shutdown system that complies with 2017 and 2020 NEC 690.12 requirements. A rapid shutdown switch should be connected to the RSD terminals on the inverter and mounted on a readily accessible location outdoors (check with your AHJ for requirements).

The APsmart Rapid Shutdown System Transmitter-PLC is part of a rapid shutdown solution when paired with APsmart RSD, a PV module rapid shutdown unit. While powered on, the Transmitter-PLC sends a signal to the RSD units to keep their PV modules connected and supplying energy. RSD units automatically enter rapid shutdown mode when the Transmitter-PLC is switched off and resume energy production when power is restored to the Transmitter-PLC.

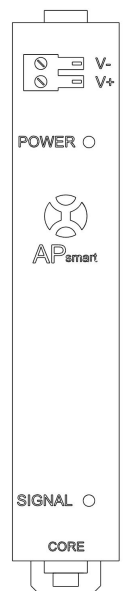

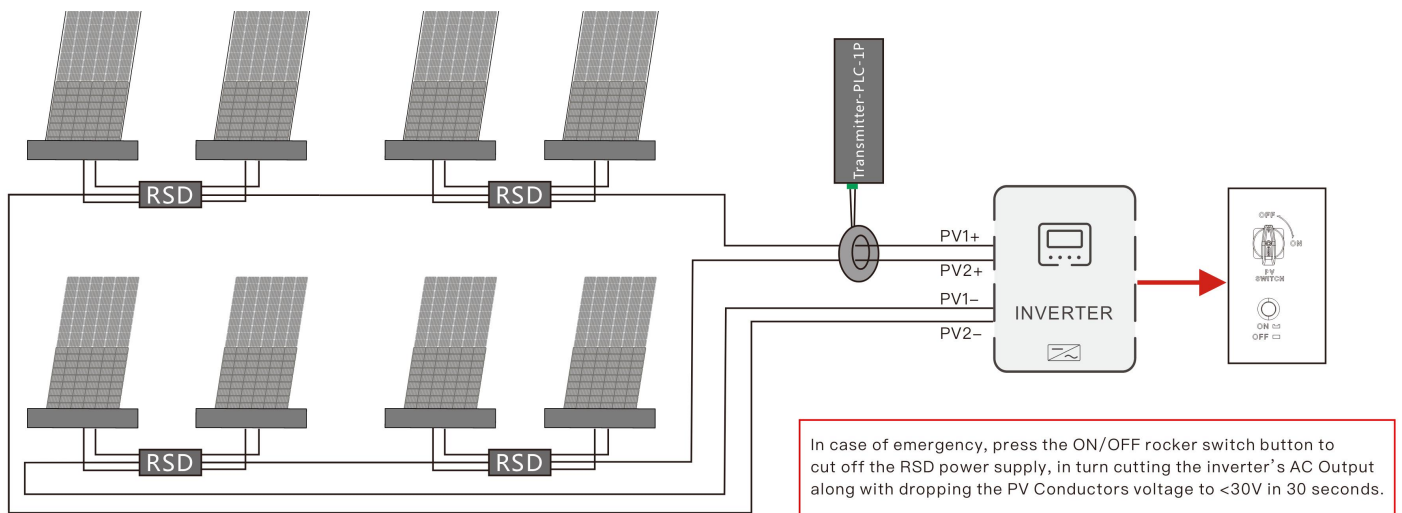

4.6 Dry Contact Connection

Use a small screwdriver to push back the direction indicated by the arrow, then insert the communication cable into the dry junction port.
 (Communication cable diameter $0.2 \sim 1.5\text{mm}^2$)

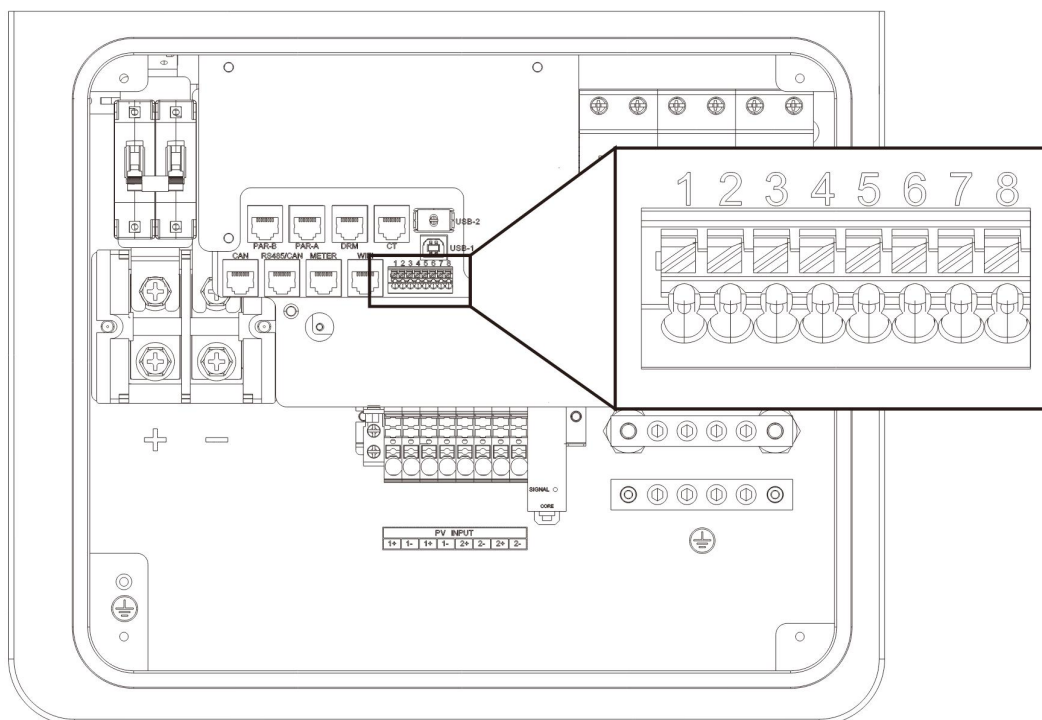

4.7 Grounding Connection

Please make sure the grounding terminal connect to the Grounding Bar.

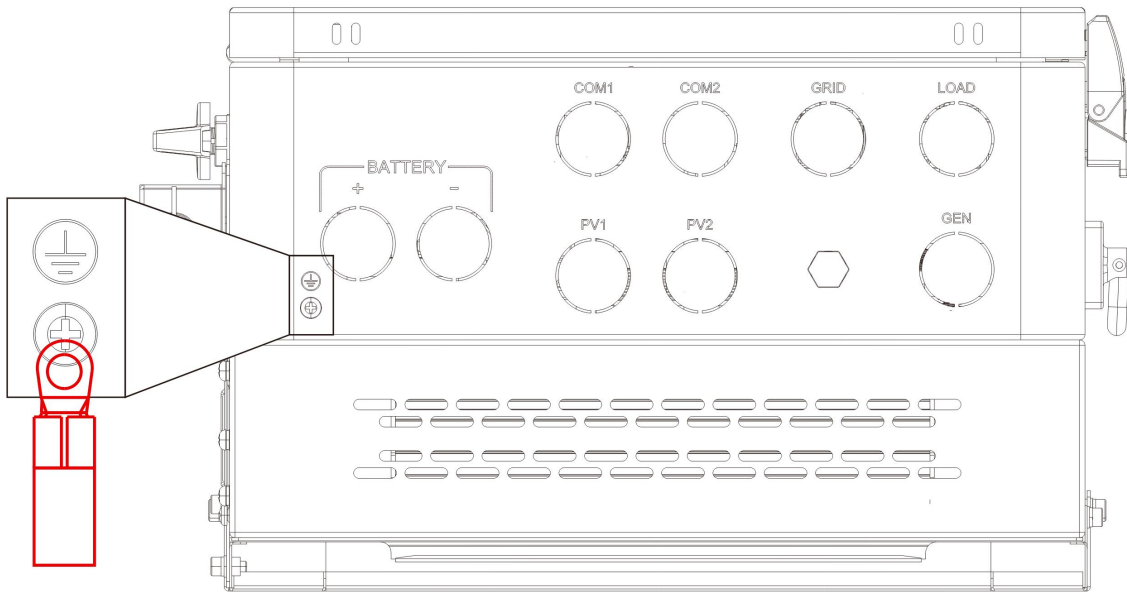

NOTICE

The grounding cable should have a diameter of not less than 4 mm² and be as close as possible to the grounding point.

4.8 Final Installation

After ensuring that the wiring is reliable and the wire sequence is correct, install the terminal protection cover in place.

- **Step 1:** Close the circuit breaker of the battery.
- **Step 2:** Press the ON/OFF switch on the side of the inverter. The screen and indicator lights turning on indicates that the inverter has been activated.
- **Step 3:** Sequential close of the circuit breakers for PV, AC input and AC output.
- **Step 4:** Start the loads one by one in order of power from small to large.

4.9 Parallel Connection

4.9.1 Introduction to Parallel Connection

1. Up to six units connected in parallel.
2. When using the parallel operation function, the following connecting lines (package accessories) shall be firmly and reliably connected.

Parallel communication line *1

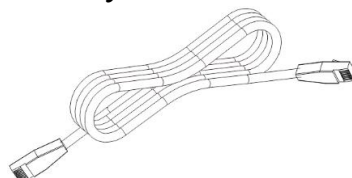

4.9.2 Precautions for Connecting the Parallel Connecting Lines



Warning

1.PV connection:

When connecting in parallel, the PV arrays connected to each inverter must be independent of each other. The PV arrays corresponding to PV1, PV2 ports of the same inverter must also be independent.

2.Battery connection:

For split-phase or three-phase parallel operations, all solar energy storage inverters must be connected to the same battery bank. Connect BAT+ to BAT+ and BAT- to BAT-. Before powering on the system, thoroughly check the wiring configuration to ensure correctness. Confirm that the wiring lengths between each inverter and the battery are consistent, and verify that the cable size meets the system's current transmission requirements. Incorrect connections may cause abnormal operation of the parallel system.

3.Load connection:

For split-phase parallel connection: all solar storage inverters must be connected in the manner of L-to-L, N-to-N, and PE-to-PE, and before power on and start-up, it is necessary to check and ensure correct connection, wiring length, and cable size, so as to avoid the abnormal operation of parallel system output caused by wrong connection.

For three-phase parallel connection: all solar storage inverters must be connected in the manner of N-to-N and PE-to-PE. The L lines of all inverters in the same phase shall be connected together, but the AC output L lines of different phases shall not be connected together. Other cautions are the same as those for split-phase parallel connection. Refer to the schematic diagram for wiring.

4.Grid connection:

In split-phase parallel connection, all solar storage inverters must be connected in the manner of L-to-L, N-to-N, and PE-to-PE, and before power on and start-up, it is necessary to check and ensure correct connection, wiring length, and cable size, so as to avoid the abnormal operation of parallel system output caused by wrong connection.

Meanwhile, it is not allowed to have multiple different AC source inputs to avoid damage to the external equipment of the inverter. The AC source input shall be consistent and unique. Refer to Chapter 4.9.3 for wiring diagrams for parallel connection.

In three-phase parallel connection, all solar storage inverters must be connected in the manner of N-to-N and PE-to-PE. The L lines of all inverters in the same phase shall be connected together, but the AC output L lines of different phases shall not be connected together. Refer to the schematic diagram for wiring.

5.Communication Lines:

Our parallel communication cable is a shielded 8-pin network cable suitable for both split-phase and three-phase parallel connections. Each unit must have one input and one output connection.

In a parallel system, the "Parallel A" interface of this machine must be connected to the "Parallel B" interface of the target machine. It is strictly prohibited to connect the "Parallel A" interface of this machine to either the "Parallel B" interface of the same machine or the "Parallel A" interface of the target machine.

Additionally, secure each unit's parallel communication cable firmly to the 8-pin network connector to prevent disconnections or poor contacts, which may lead to abnormal system operation or damage to the output.

6. Before and after connecting the system, carefully refer to the system wiring diagram below. Ensure all connections are correct and secure before powering on.

7. After the system is correctly wired, powered on, and operating normally, if a new inverter needs to be connected, ensure that the battery input, PV input, AC input, and AC output are disconnected, and all solar energy storage inverters are powered off before reconnecting to the system.

4.9.3 Schematic Diagram for Split-Phase Parallel Connection

Settings for each inverter: Select "Parallel" for the parallel mode and "Split Phase " for the Grid type, when the output phase voltage is selected as "120V", the output L1-L2 voltage is 240V, the L1-N voltage is 120V, and the L2-N voltage is also 120V

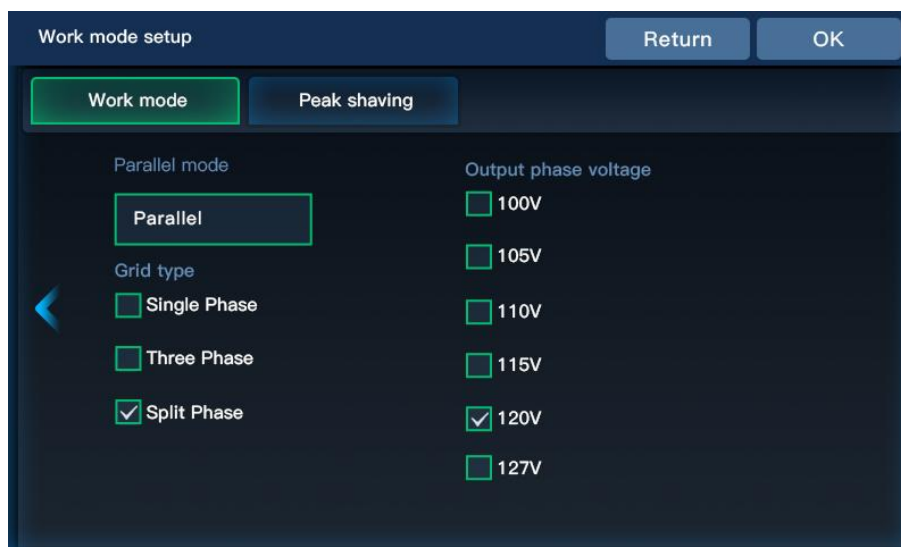

When multiple units are operating in parallel, the schematic diagram for parallel connection guidance is as follows:

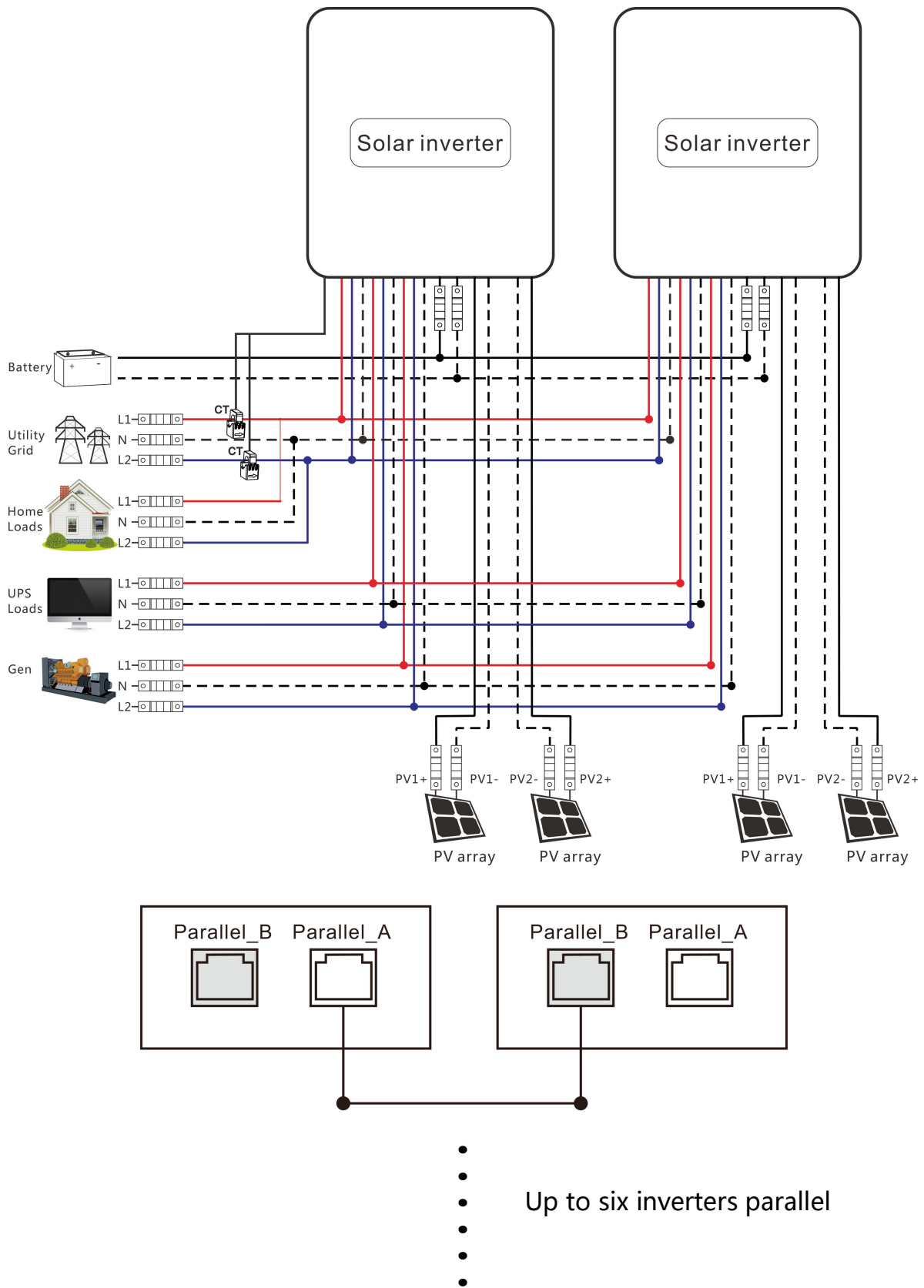



4.9.4 Schematic Diagram for Three-Phase Parallel Connection

1.Ensure the parallel communication cables of solar energy storage inverters are securely clamped without looseness.

2.When multiple inverters are operating in parallel, refer to the following schematic diagram:

① **Two inverters are connected in parallel for three-phase output (three-phase imbalance)**

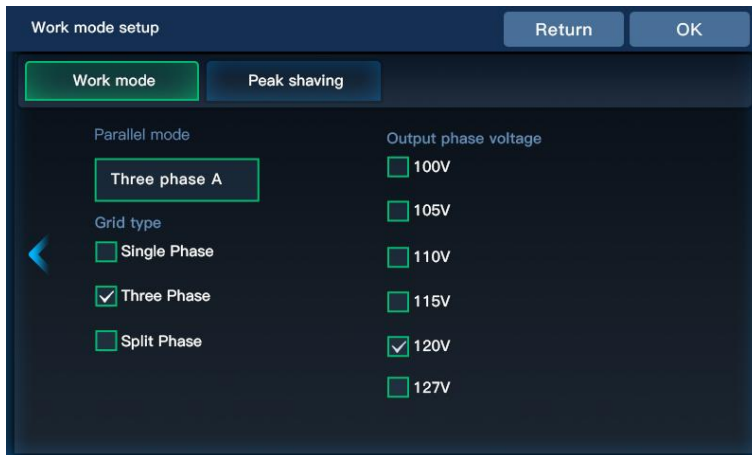

P1 machine set: Select "Three phase A" for the parallel mode and "Three Phase " for the Grid type,when the output phase voltage is selected as "120V", the output L1-L2 voltage is 208V, the L1-N voltage is 120V, and the L2-N voltage is also 120V.



P2 machine set: Select "Three phase B" for the parallel mode and "Three Phase " for the Grid type,when the output phase voltage is selected as "120V", the output L1-L2 voltage is 208V, the L1-N voltage is 120V, and the L2-N voltage is also 120V.

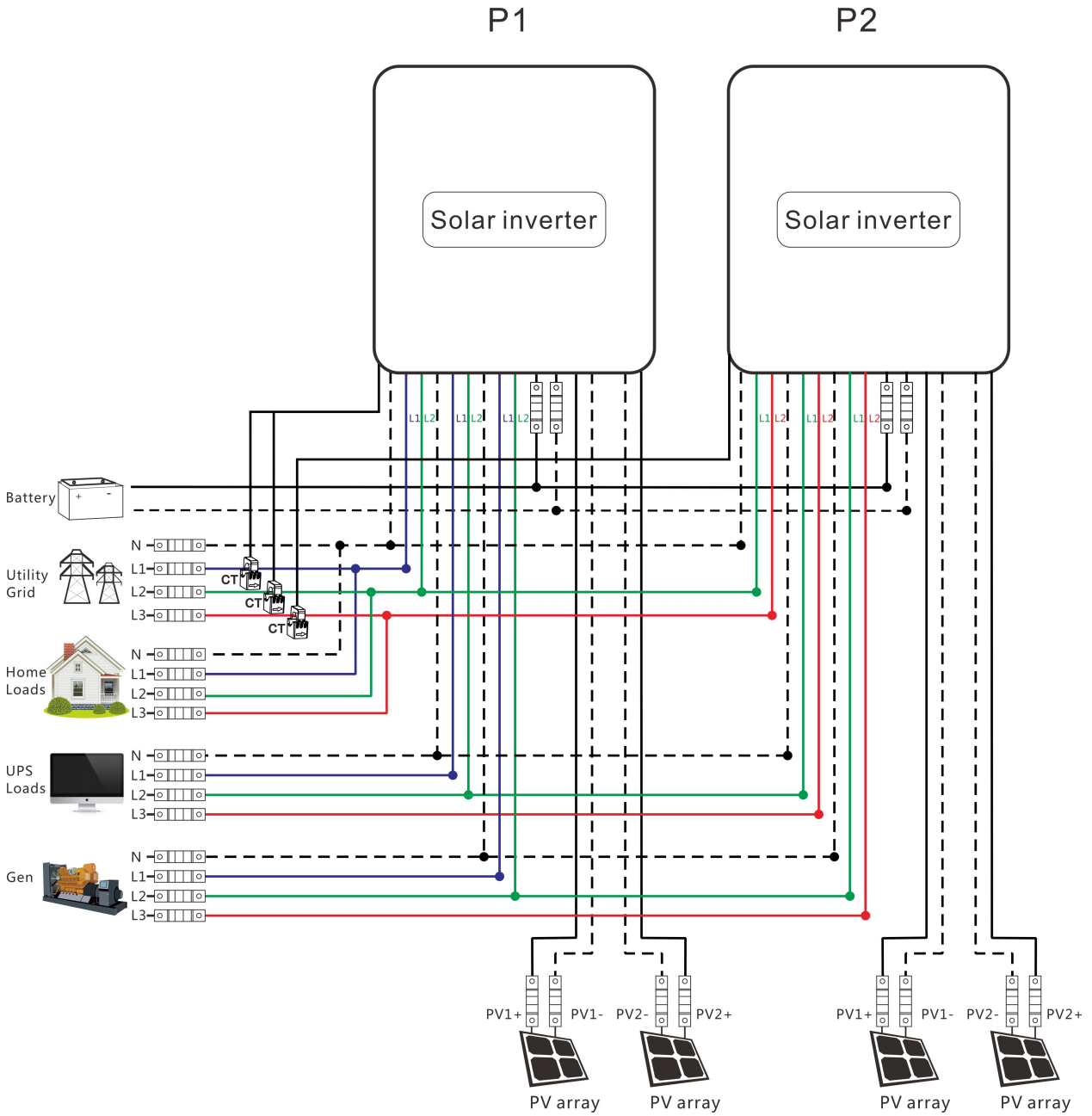

P1

P2

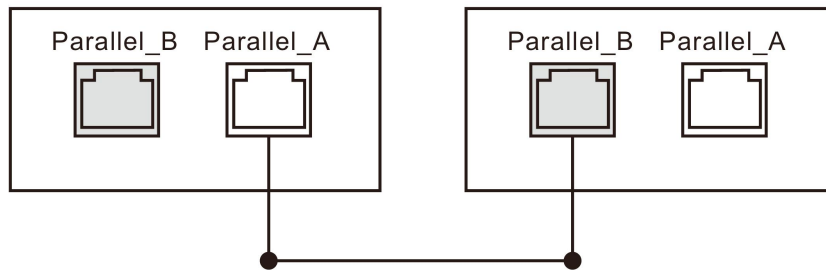

② Three or six inverters are connected in parallel for three-phase output (three-phase balance)

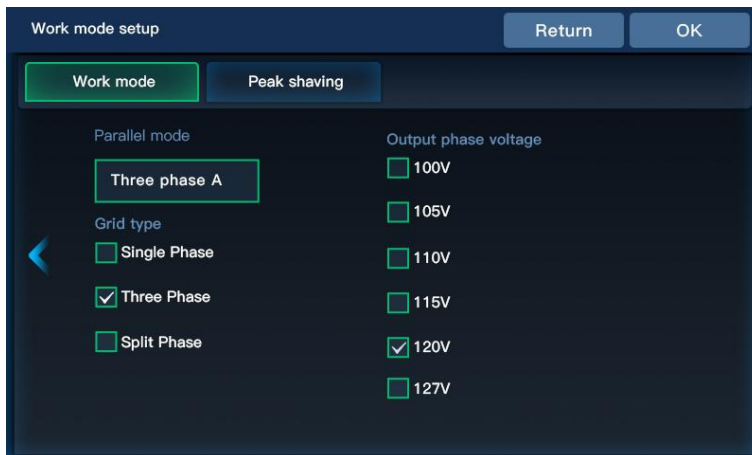

P1 machine set:Select "Three phase A" for the parallel mode and "Three Phase " for the Grid type,when the output phase voltage is selected as "120V", the output L1-L2 voltage is 208V, the L1-N voltage is 120V, and the L2-N voltage is also 120V.



P2 machine set:Select "Three phase B" for the parallel mode and "Three Phase " for the Grid type,when the output phase voltage is selected as "120V", the output L1-L2 voltage is 208V, the L1-N voltage is 120V, and the L2-N voltage is also 120V.

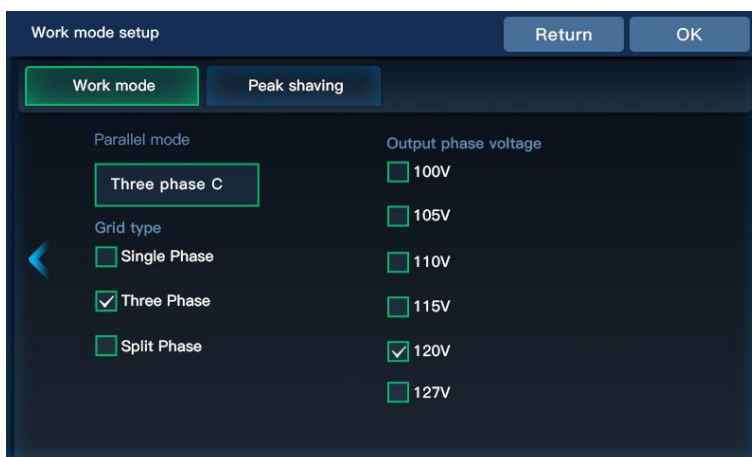

P3 machine set:Select "Three phase C" for the parallel mode and "Three Phase " for the Grid type,when the output phase voltage is selected as "120V", the output L1-L2 voltage is 208V, the L1-N voltage is 120V, and the L2-N voltage is also 120V.

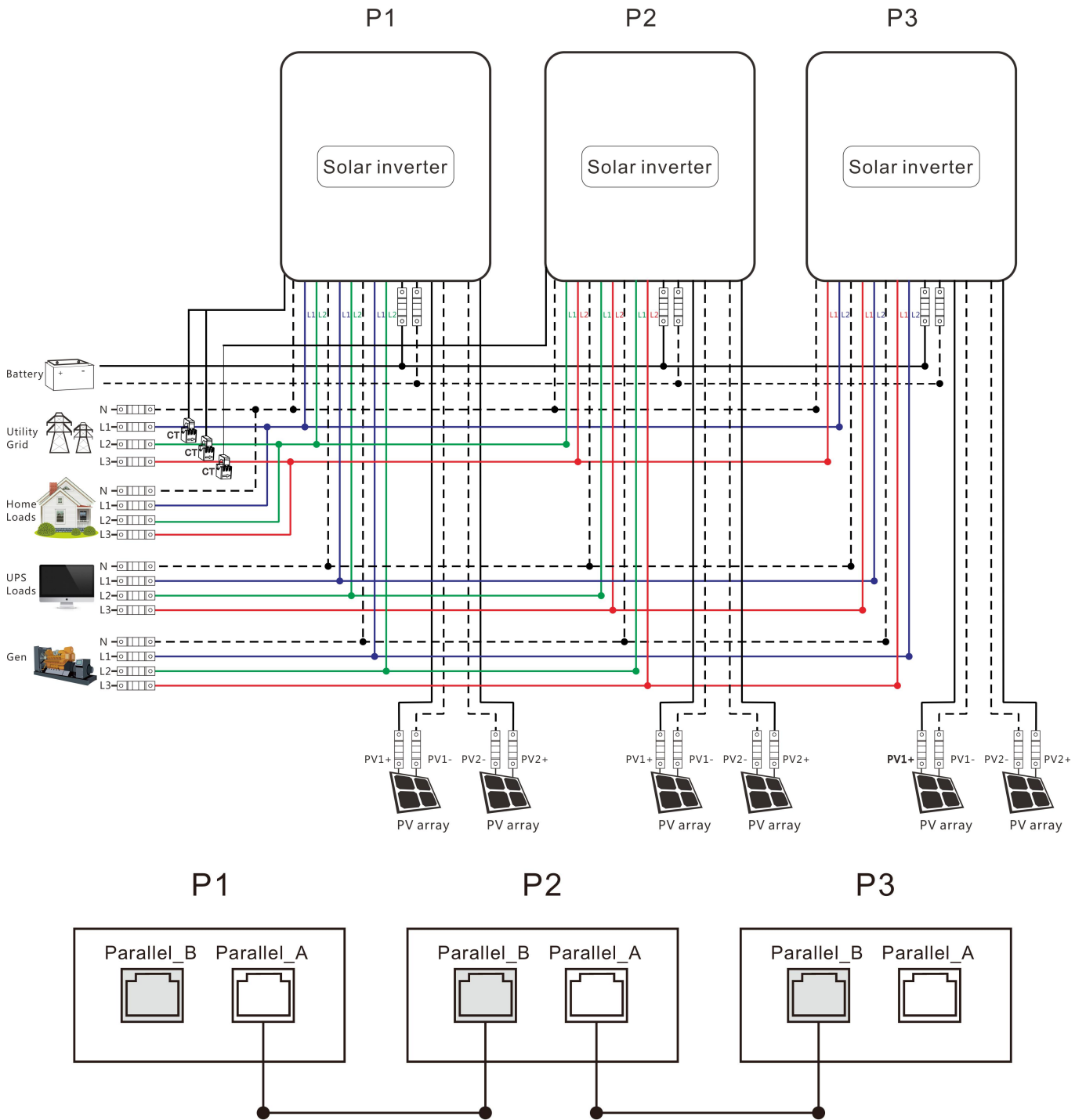

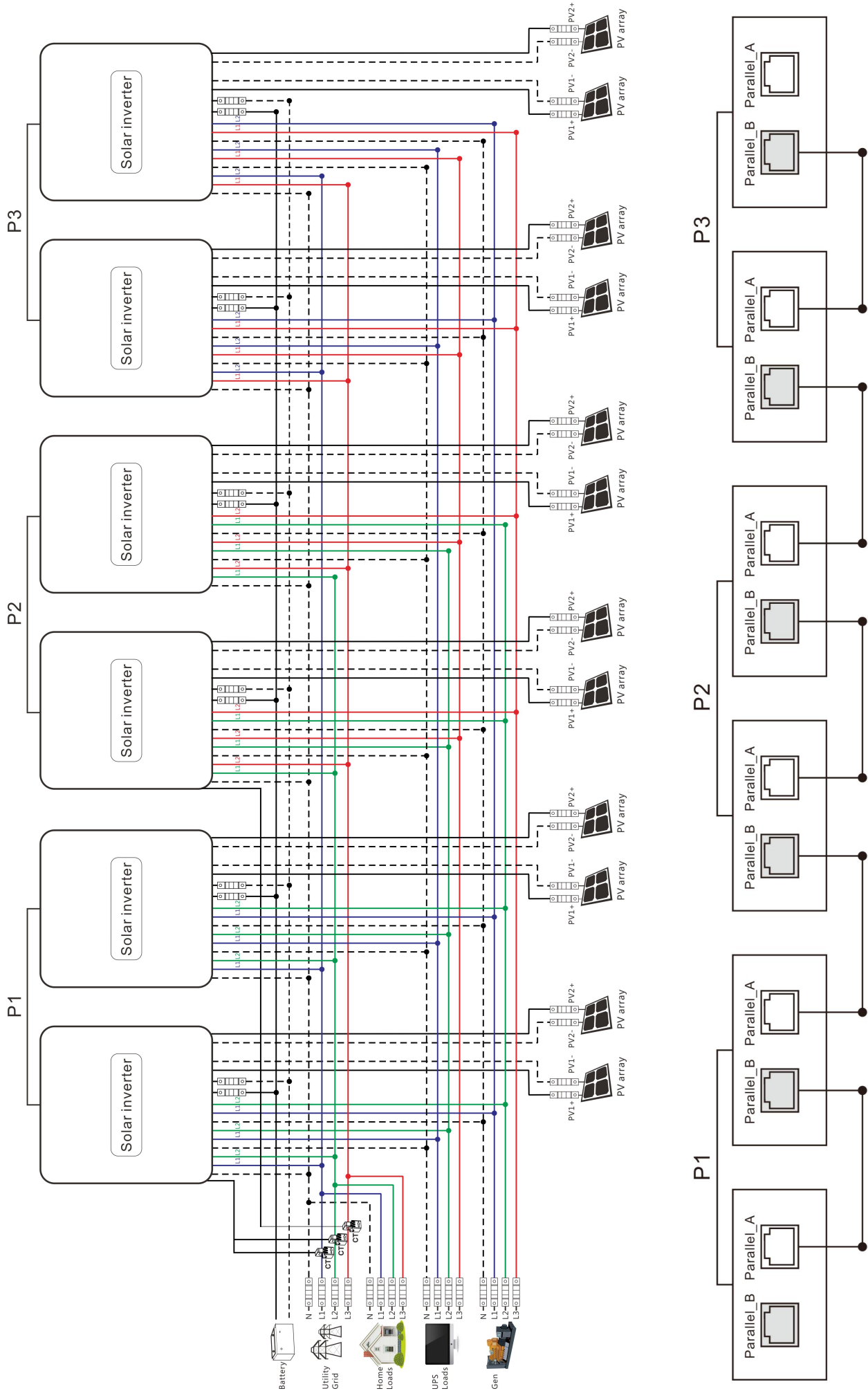

Notice:

- ① Before starting up and running, please check whether the connection was correct to avoid any abnormalities in the system.
- ② All wiring must be fixed and reliable to avoid wire drop during use.
- ③ When the AC output is wired to the load, it shall be properly wired according to the requirements of the electrical load equipment to avoid damage to the load equipment.
- ④ Setting item “output phase voltage setting” needs to be set consistently or only for the master. When paralleling, the voltage set by the master will prevail, and the master will be forced to rewrite the rest of the slaves to be consistent. This option can be set in standby mode only.
- ⑤ Machine factory default for split machine mode, if you use parallel or three-phase function, you need to set the “Parallel mode” item parameters through the screen. The setting method is: power on one machine at a time, the rest of the machine off, and then set the “Parallel mode” item parameters according to the site system operation mode. After this machine is set successfully, turn off the machine switch and wait for the machine to be powered down, then set the rest of the machines in turn until all machines are set, and then all machines are powered up again at the same time and enter the working state.
- ⑥ After the system runs, the output voltage is measured correctly, and then connect the load.



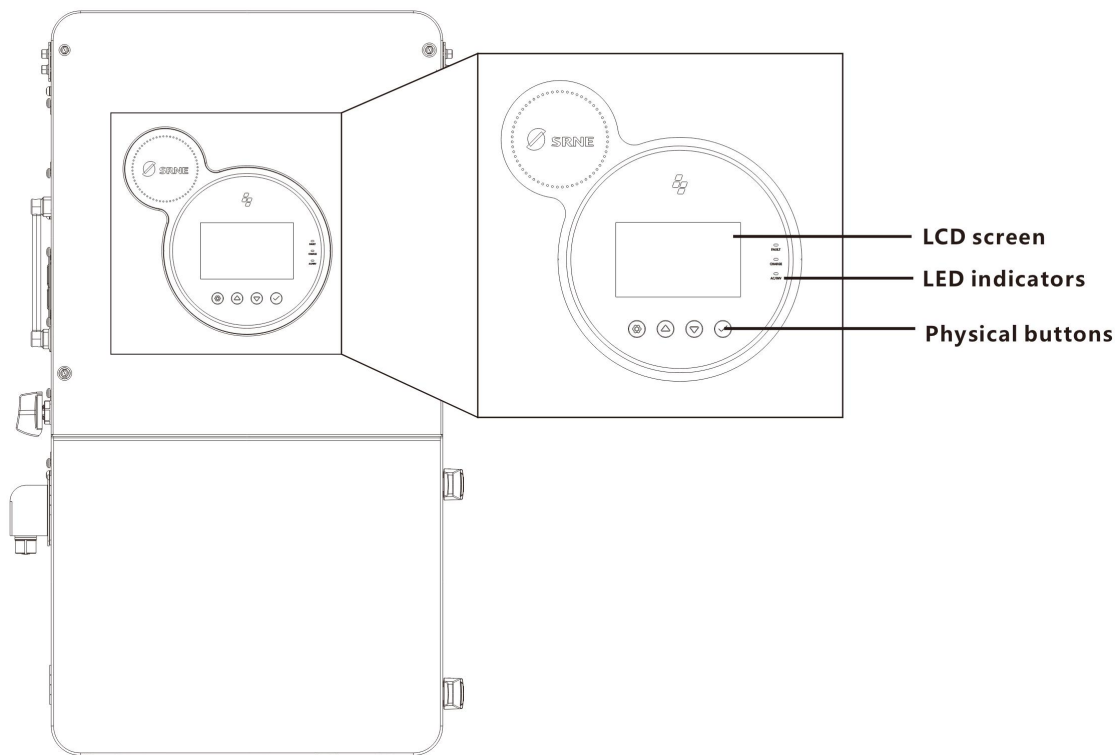

5. Operation

5.1 Operation and Display Panel

The operation and display panel below includes 1 LCD screen, 3 LED indicators, and 4 physical buttons.



■ Physical buttons

Button	Description
	To enter/exit settings menu
	To go to previous selection
	To go to next selection
	To confirm/enter selection in settings menu

■ LED indicators

Indicator	Color	Description
FAULT	Red	Flashing: Error occurred
		Continued: Error occurred
CHARGE	Green	Steady on: charging completed
		Flashing: charging in progress
AC/INV	Yellow	Steady on: utility grid by-pass output
		Flashing: inverter output

■ Display Panel



Icon	Description	Icon	Description
	Solar Panel		Load
	Battery		Grid
	Home Page		Inverter is Working
	Historical Data		Setting
0 : 0 : 0	Local Time		The buzzer is silent
	Indicates that the machine is currently in energy-saving mode.		The energy direction
UPS	UPS Load	HOME	Household Load
	Smart Load		Generator

■ View real-time data

On the LCD main screen, tapping the inverter icon, battery icon, mains power icon, load icon, and photovoltaic (PV) icon allows viewing of all real-time data of the machine.

System Data			
No.	Real - time data items	No.	Real - time data items
1	Machine Status	11	SN Code
2	MCU1 Version	12	Minor Version Number
3	LCD Version	13	Rated Power
4	MCU2 Version	14	RS485 Address

5	Customer ID	15	External Temperature
6	Inverter Temperature	16	PV Temperature
7	Transformer Temperature	17	L1 Voltage
8	L1 Current	18	L2 Voltage
9	L2 Current	19	BUS+ Voltage
10	BUS- Voltage	20	Total BUS Voltage
Battery Data			
1	SOH	6	Discharging Current
2	Battery SOC (%)	7	BMS Communication Protocol
3	Battery Voltage	8	Battery Type
4	Charging Current	9	Battery Charging Status
5	Battery Power (Battery Charge/Discharge Power)		
Utility Data			
1	L1 Voltage	6	L2 Voltage
2	L1 Current	7	L2 Current
3	L1 Active Power (Positive for Selling Electricity, Negative for Buying Electricity)	8	L2 Active Power (Positive for Selling Electricity, Negative for Buying Electricity)
4	L1 Apparent Power	9	L2 Apparent Power
5	Frequency	10	Mains Charging Current
Load Data			
1	L1 Voltage	8	L2 Voltage
2	L1 Current	9	L2 Current
3	L1 UPS Load Active Power	10	L2 UPS Load Active Power
4	L1 UPS Load Apparent Power	11	L2 UPS Load Apparent Power
5	Frequency	12	Load Rate
6	L1 Home Load Power	13	L2 Home Load Power
PV Panel Data			
1	PV1 Voltage (V)	5	PV2 Current (A)
2	PV1 Current (A)	6	PV2 Power (W)
3	PV1 Power (W)	7	Total Photovoltaic Power
4	PV2 Voltage (V)		
Generator Data/Smart Load Data/Microinverter Data			
1	L1 Voltage	7	L2 Voltage
2	L1 Current	8	L2 Current
3	L1 Active Power	9	L2 Active Power
4	L1 Apparent Power	10	L2 Apparent Power
5	Frequency	11	Total Power
6	Charging Current (Generator Only)		

Click the History button in the lower menu bar to access historical data and view various types of historical data in the inverter industry.

Today Data			
1	Battery Charging Capacity	6	Load Consumption from Mains
2	Battery Discharge Capacity	7	Grid-connected Power Generation
3	Solar Power Generation	8	Generator Discharge Capacity
4	Load Consumption	9	Generator Charging Amount
5	Grid Charging Amount	10	Household Load Consumption
Historiy			
1	Last Seven Days PV Power Generation	4	Last Seven Days Grid Charging Amount
2	Last Seven Days Battery Charging Capacity	5	Last Seven Days Load Consumption
3	Last Seven Days Battery Discharge Capacity	6	Last Seven Days Load Consumption from Grid
Battary Statistics			
1	Battery Total Charging Capacity	6	Load Total Consumption from Grid
2	Solar Total Power Generation	7	Total Load Consumption of Grid Energy
3	Grid Total Charging Amount	8	Generator Total Discharge Capacity
4	Battery Total Discharge Capacity	9	Generator Total Charging Capacity
5	Load Total Consumption	10	Household Load Total Energy Consumption
Historical Faults			
Click to enter the interface and display the fault history.			

5.2 Setting Parameters

Operation Instructions: Click Settings in the lower menu bar of the screen to enter the settings interface, which includes five categories of settings: Basic Settings, Working Mode Settings, Battery Settings, Grid-connected Settings, and Pre-settings.

5.2.1 Basic Settings

5.2.1.1 Display Setting

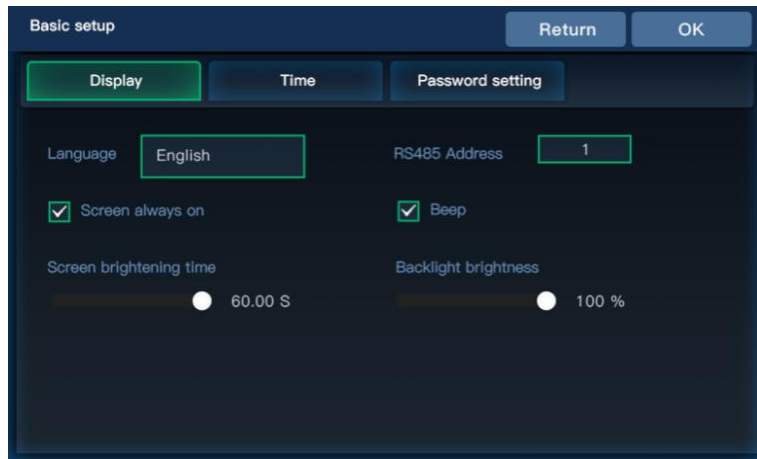

- **Language:** English, Italian, German, Spanish, Chinese, Polish, Vietnamese.
- **RS485 Address:** Refers to the RS485 address of the inverter. For a split unit, the adjustable range is 1~254, and for parallel units, it is 1~ 6.
- **Screen always on:** Selectable whether the screen is always on or not.
- **Beep:** Select whether to enable buzzer alarm.
- **Screen brightening time:** Setting range 1 to 60 seconds.

- **Backlight brightness:** Adjustable from 0 to 100%.

5.2.1.2 Time Settings

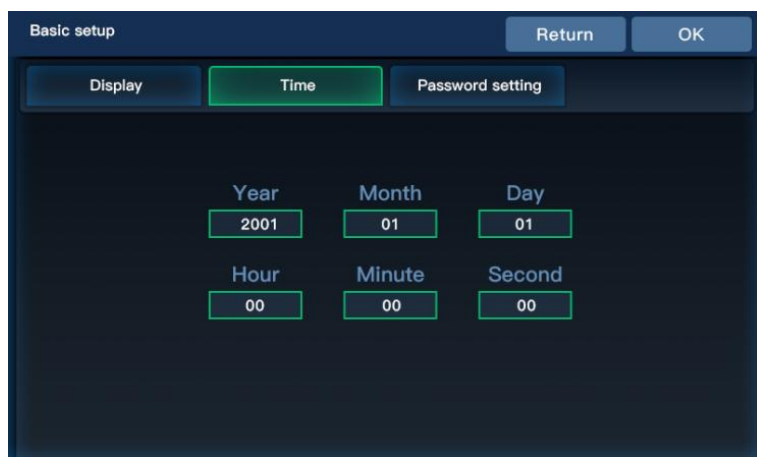

- Supports modification of year/month/day.
- Supports modification of hour/minute/second.

5.2.1.3 Password Settings

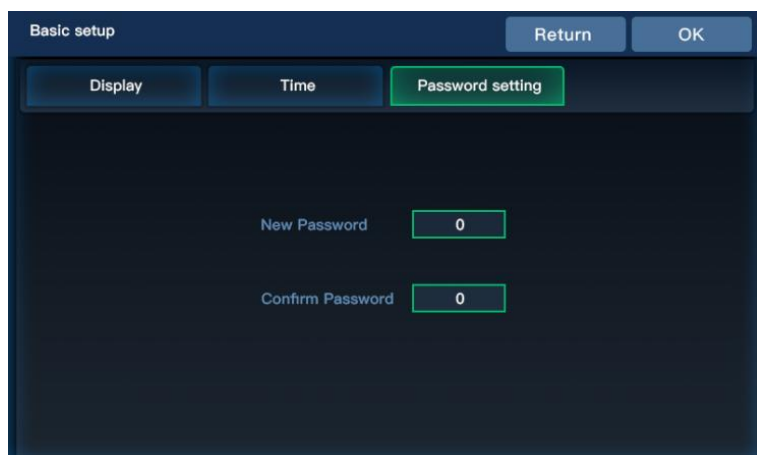

- Default password: **4321**.
- Password setting range: **0~9999**.

5.2.2 Operation Mode Settings

5.2.2.1 Working Mode

Home Load: connected to the GRID port of the machine, requires external CT for monitoring.

UPS Load: connected to the LOAD port of the machine.



● Hybrid grid mode:

- ① **On grid:** Grid-connected mode. PV or battery energy can be fed into the grid.
- ② **Limit power to UPS load:** The inverter will neither sell power to the grid nor export power to the home load, PV or battery energy is only supplied to the UPS load.
- ③ **Limit power to home load:** The inverter will not sell power to the grid, PV or battery power is supplied to the UPS, home load and smart loads.(Need CT)
- ④ **AC Coupling:** Connect the grid-connected inverter to the grid side or generator port of the hybrid inverter.

- **PV energy manage:** When the hybrid grid mode is set to "Limit power to UPS" or no CT is connected, the following loads refer to the UPS load. When the hybrid grid mode is set to "Limit power to home"/"On grid" and a CT is connected, the following loads refer to the UPS load plus the home load.

- ① **First to Load:** PV energy supply priority: Load → charge → On Grid.
Microinverter energy supply priority: Load → charge → On Grid.
- ② **First to charging:** PV energy supply priority: charge → Load → On Grid.
Microinverter energy supply priority: Load → charge → On Grid.
- ③ **First to grid:** PV energy supply priority: Load → On Grid → charge .
Microinverter energy supply priority: Load → On Grid → charge .

- **Grid charging enable:** Selectable grid participation in battery charging.

● Battery energy manage:

- ① **Standby:** Battery only discharge in off-grid working mode.
- ② **Battery to UPS load:** When the PV power is lower than the UPS load power, the battery discharges to supplement the power.
- ③ **Battery to home load:** When the PV power is less than the total load power, the battery discharges to supply supplementary power for UPS loads, smart loads, and household loads.
- ④ **Battery to grid sell:** In addition to supplying power to loads, the battery can also feed electricity into the grid for sale.

● Parallel mode:

- ① stand-alone; ② split phase parallel; ③ three phase A; ④ three phase B; ⑤ three phase C

Three-phase Parallel Connection Settings:

All machines with output L connected in parallel to phase A must be set to [three phase A].

All machines with output L connected in parallel to phase B must be set to [three phase B].

All machines with output L connected in parallel to phase C must be set to [three phase C].

- **Output phase voltage:** Settable 100V,105V,110V,120V,127V

5.2.2.2 Peak Shaving



The screenshot displays the 'Work mode setup' interface for 'Peak shaving'. It is divided into two main sections. The top section, titled 'Work mode setup', has 'Peak shaving' selected. It contains two main options: 'Timed charging enable' and 'Timed discharging enable', both of which are checked. Each option has a table with three rows and five columns: 'Start Time', 'End Time', 'Stop SOC', 'Stop Volt', and 'Max Power'. All values in these tables are set to 00:00, 00:00, 100%, 60.0V, and 60W respectively. The bottom section, also titled 'Work mode setup', has 'Peak shaving' selected and shows 'Week enable' settings for Monday through Sunday, all of which are checked.

- **Timed charging enable:** Select whether to enable timed charging.

- **Timed discharging enable:** Select whether to enable timed discharging.

- **Max. consumption enable:** When this option is enabled, the battery operates according to the battery energy management settings during non-timed charge-discharge periods. During non-timed charge-discharge periods, the battery operates in accordance with the battery energy management settings.

- **Start/End Time:** Set the time period for timed charging/discharging.

- **Stop SOC:** Set the battery charging cut-off SOC value and the discharge cut-off SOC value during timed charge-discharge periods (during BMS communication).

- **Stop Volt:** Set the battery charging cut-off voltage and discharge cut-off voltage during timed charge-discharge periods (when BMS communication is inactive).

- **Max. Power:** Set the battery charging power and discharging power during timed charge-discharge periods.

- **Grid:** When configuring timed charging, select the grid as the battery charging source.

- **Gen:** When configuring timed charging, select the generator as the battery charging source.

- **Week Enable:** Set the specific days of the week for timed charging/discharging (applicable only to the timed charging/discharging function).

5.2.3 Battery Settings

5.2.3.1 Battery Type

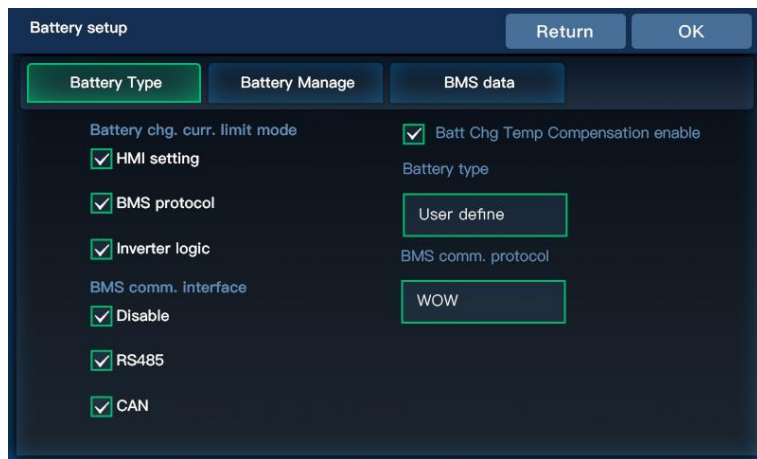

● **Battery chg. curr. limit mode(valid for BMS communication):**

- ① **HMI setting:** Maximum battery charging current is limited according to the inverter battery charging current setting value.
- ② **BMS protocol:** Maximum battery charging current is limited by the current limit value of the BMS.
- ③ **Inverter logic:** Maximum battery charging current is limited by the machine's derating logic.

● **BMS comm. interface:**

- ① **Disable:** BMS does not communicate.
- ② **RS485:** BMS RS485 communication function.
- ③ **CAN:** BMS CAN communication function.

● **Batt. Chg. Temp Compensation enable:** Select whether to turn on temperature compensation.

● **Battery type:**

- ① **USER define:** User customizable to set all battery parameters.
- ② **SLd:** Sealed Lead-acid Battery.
- ③ **FLd:** Flooded Lead-acid Battery.
- ④ **GEL:** Gel Lead-acid Battery.
- ⑤ **LFP/14/ 15/LFP 16:** Li-FePO₄ /14/15/16, corresponding to 14-series, 15-series, and 16-series Li-FePO₄ batteries.
- ⑥ **N13/ N14:** NCM Lithium Battery N13/N14, corresponding to 13-series and 14-series NCM lithium batteries.
- ⑦ **No battery:** No battery connected.

● **BMS comm. protocol:** When the BMS port selection item is set to RS485 or CAN, the corresponding lithium battery manufacturer brand shall be selected for communication:

	1	2	3	4	5
	PACE=PACEEX	RUDA=RADAR	AUTOONE	OULITE=OLITER	CEF=CFGE
	7	8	9	6	10
CAN	DAQIN=Dyness	WOW=SRNE	PYL=Pylontech	XINWANGDA	MIT=FOX ESS
	11	12	13	14	15
	XIX=Xinyi energy	POL=PowMr	GUOX=GOTION	SMK=SMK POWER	VOL=VILION
	16	17	18	19	
485	UZE=UZENERGY	PYL=Pylontech	DEYE	WOW=SRNE	

Note: Please refer to the actual display on the screen.

5.2.3.2 Battery Manage



Battery setup [Return] [OK]

Battery Type	Battery Manage	BMS data	
Maximum chg. voltage	12.0V	Maximum chg. current	1.0A
Batt. Recharging voltage	12.0V	Max. chg. curr. by Grid	12.0A
Battery curr. stop chg.	1.0A	Bat. SOC stop chg.	12%

Battery setup [Return] [OK]

Battery Type	Battery Manage	BMS data	
Batt. volt. stop dischg. in hybrid	12.0V	Batt. SOC stop dischg. in hybrid	10%
Batt. volt. restart dischg.	12.0V	Batt. SOC restart dischg.	15%
Battery under volt. alarm	12.0V	Batt. under capacity alarm	12%
Batt. volt low recovery	12.0V	Batt. SOC low fault	10%
Batt. voltage low fault	12.0V	Batt. volt. low fault delay	5S
Battery max. curr. dischg.	10.0A		

- **Maximum chg. voltage:** When the battery is charging, the voltage reaches the value to enter the float state or stop charging.
- **Batt. Recharging voltage:** When the battery is fully charged, the inverter stops charging and resumes charging when the battery voltage falls below this voltage value.
- **Battery curr. stop chg.:** When the charging current falls below this setting, the battery will stop charge.
- **Maximum chg. current:** Set the battery charging current. When BMS communication is normal, the charging current parameter will be associated with the charging current limit value uploaded by the BMS. In this case, the set value cannot be greater than the limit value, otherwise the setting will fail.
- **Max. chg. curr. by Grid:** When using mains charging, set the size of the battery mains charging current (this value is the battery current, DC).

- **Bat. SOC stop chg.:** When the SOC value reaches the set point, charging will stop (valid when BMS communication is normal).
- **Batt. volt. stop dischg. in hybrid:** In hybrid grid mode (when the grid is connected), the battery will cease discharging once it reaches this set value.
- **Batt. volt. restart dischg.:** When the inverter output is disconnected due to low battery voltage, the battery voltage must exceed this set value to resume the battery's inverter AC output.
- **Battery under volt. alarm:** Battery under-voltage alarm point, when the battery voltage is lower than the judgment point, the under-voltage alarm will be reported and the output will not be turned off.
- **Batt. volt low recovery:** After the battery is over-discharged, it will resume discharging when its voltage reaches this set value.
- **Batt. voltage low fault:** In off-grid mode, the inverter will shut down due to battery undervoltage; in hybrid-grid mode, the battery will stop discharging due to undervoltage.
- **Battery max. curr. dischg.:** Set the max battery discharger current.
- **Batt. SOC stop. dischg. in hybrid:** In hybrid-grid mode, the battery will stop discharging when its SOC drops below this set value; in off-grid mode, the battery will continue discharging when its SOC drops below this set value.
- **Batt. SOC restart dischg.:** When the battery report SOC low fault, the battery SOC reach this setting, it can restart discharge(valid when BMS communication is normal).
- **Batt. under capacity alarm:** SOC value up to this setting will alarm. The inverter output will not shut down and the fault disappears if the SOC value exceeds 5% of the set value. (Valid when BMS communication is normal).
- **Batt. SOC low fault:** When the battery voltage reach this setting, the inverter will report battery SOC low fault and stop discharging(valid when BMS communication is normal).
- **Batt. Volt. low fault delay:** When the battery voltage reaches the "Batt. voltage low fault" setting, the battery will stop diacharging with a delay.

5.2.3.3 BMS Data (During Battery-Inverter Communication)

Battery setup
Return
OK

Battery Type	Battery Manage	BMS data
Battery Voltage:	33.3V	Battery charge voltage: 33.3V
Battery Current:	33.3A	Charge current limit: 33.3A
Battery Temp.:	33.3°C	Discharge current limit: 33.3A
SOH:	33%	Battery rated capacity: 33AH
Number of battery cycles:	4444	Battery remain capacity: 33AH
Alarms 1:	50000	Protection 1: 50000
Alarms 2:	50000	Protection 2: 50000

Mainly used to view data uploaded by the BMS to the inverter.

5.2.4 Grid Connection Settings

Access to this setting requires entering the user-defined password, with the default password being "4321".

5.2.4.1 Basic Page

On grid setup
Return
OK

Basic
Enter Service
Grid Protection
Other

Grid standard <input style="width: 100%;" type="text" value="Not Initialized"/>	On Grid Reactive Power <input style="width: 100%;" type="text" value="0%"/>	<ul style="list-style-type: none"> ● Grid standard (subject to the actual display on the screen.): United States: UL1741 & IEEE1547.1-2020 California, United States: RULE21; Hawaii, United States: HECO Other regions: GNL ● Grid frequency: Select the local grid frequency (50Hz/60Hz). ● Sell Power Max.: Set the maximum grid-connected power.
Grid frequency <input type="checkbox"/> 50Hz <input checked="" type="checkbox"/> 60Hz	<input checked="" type="checkbox"/> Reactive power over excited <input type="checkbox"/> Reactive power under excited	
Sell Power Max <input style="width: 100%;" type="text" value="6000W"/>	External CT ratio <input style="width: 100%;" type="text" value="2000:1"/>	
Buy Power Max <input style="width: 100%;" type="text" value="6000W"/>	On Grid PF <input style="width: 100%;" type="text" value="1.000"/>	
zero-export power <input style="width: 100%;" type="text" value="20W"/>	<input checked="" type="checkbox"/> Reactive power over excited <input type="checkbox"/> Reactive power under excited	

- **External CT ratio:** When connecting an external CT, enter the ratio on the CT specification.
- **Buy Power Max.:** Maximum power drawn from the power grid. If the power grid charging power + load power exceeds this setting value, the machine will reduce the charging power. (Setting range: 0 to rated power).
- **Zero-export power:** In the event of anti-reverse flow, the error calibration power is used to adjust the sampling error of the inverter. The default value is 20W, with an adjustment range of ± 100 W. By adjusting this value, the actual active power on the grid side is made to approach zero.
- **On-Grid Reactive Power:** Setting range of reactive power percentage: 0% to 100%
- **Reactive power over/under excited:** "over" indicates 0%-100% / "under" indicates -100% ~ 0%.
- **On Grid PF:** Setting range 0.8~1.
- **Power factor over/under excited:** "over" indicates / "under" indicates -0.8 ~ -1.

5.2.4.2 Enter Service Parameters (It is not recommended for users to change this suggested item)



On grid setup							
Return OK							
Basic		Enter Service		Grid Protection		Other	
Connect Voltage Low	234.5V	Connect Frequency Low	50.00Hz				
Connect Voltage High	234.5V	Connect Frequency High	50.00Hz				
Normal connect delay time	50S	Normal Connect Power Ramp Rate	50S				
Reconnect delay time	50S	Reconnect Power Ramp Rate	50S				

- **Connect voltage low:** Minimum voltage requirement for grid connection.
- **Connect voltage high:** Maximum voltage requirement for grid connection.
- **Connect frequency low:** Minimum frequency requirement for grid connection.
- **Connect frequency high:** Maximum frequency requirement for grid connection.
- **Normal connect delay time:** The delay time for the inverter to connect to the grid when the grid first meets the access requirements.

- **Normal connect power ramp rate:** The ramp rate of grid-connected power for the first grid connection.
- **Reconnect delay time:** The delay time for the inverter to reconnect to the grid when the grid resumes meeting the access requirements after a disconnection.
- **Reconnect Power Ramp Rate:** The ramp rate of grid-connected power for grid reconnection after a disconnection.

5.2.4.3 Grid Protection Parameters (It is not recommended for users to change this suggested item)



On grid setup							
Return OK							
Basic		Enter Service		Grid Protection		Other	
LV1	234.5V	Time	2ms	LF1	100HZ	Time	2ms
LV2	234.5V	Time	2ms	LF2	100HZ	Time	2ms
HV1	234.5V	Time	2ms	HF1	100HZ	Time	2ms
HV2	234.5V	Time	2ms	HF2	100HZ	Time	2ms

- **Time:** Protection response time.
- **LV1:** Level 1 Undervoltage Protection Threshold. When the grid voltage drops below this threshold and remains so for the corresponding protection response time, the inverter shall disconnect from the grid.

- **LF1:** Level 1 Underfrequency Protection Threshold. When the grid frequency drops below this threshold and remains below it for the corresponding protection response time, the inverter shall disconnect from the grid.
- **LV2:** Level 2 Undervoltage Protection Threshold. When the grid voltage drops below this threshold and remains below it for the corresponding protection response time, the inverter shall initiate grid disconnection.
- **LF2:** Level 2 Underfrequency Protection Threshold. When the grid frequency drops below this threshold and remains below it for the corresponding protection response time, the inverter shall disconnect from the grid.

- **HV1:**
Level 1 Overvoltage Protection Threshold.
When the grid voltage rises above this threshold and remains above it for the corresponding protection response time, the inverter shall disconnect from the grid.
- **HF1:**
Level 1 Overfrequency Protection Threshold.
When the grid frequency exceeds this threshold and remains above it for the corresponding protection response time, the inverter shall disconnect from the grid.
- **HV2:**
Level 2 Overvoltage Protection Threshold.
When the grid voltage exceeds this threshold and persists above it for the preconfigured protection response time, the inverter shall initiate grid disconnection.
- **HF2:**
Level 2 Overfrequency Protection Threshold.
When the grid frequency exceeds this threshold and remains above it for the specified protection response time, the inverter shall disconnect from the grid.

5.2.4.4 Others (It is not recommended for users to change this suggested item)



- **Volt-Watt (V-P) curve enable:**
Regulates the active power of the inverter according to the set grid voltage.
- **Volt-Var (V-Q) curve enable:**
Adjustment of the inverter reactive power according to the set grid voltage.
- **Watt-Var (P-Q) curve enable:**
Adjustment of the inverter reactive power according to the set active power.

- **Watt-PF (P-PF) curve enable:** Adjustment of the inverter power factor according to the set active power.
- **Frequency Droop (F-P) enable:** Adjustment of inverter output power according to grid frequency.
- **LVRT/HVRT enable:** Adjustment of the grid HV ride-through / LV ride-through values.
- **Reactive power percentage enable**
- **Discharge PF enable**
- **Charge PF enable**

5.2.5 Advanced Settings

Access to this setting requires entering the user-defined password, with the default password being "4321".

5.2.5.1 Generator

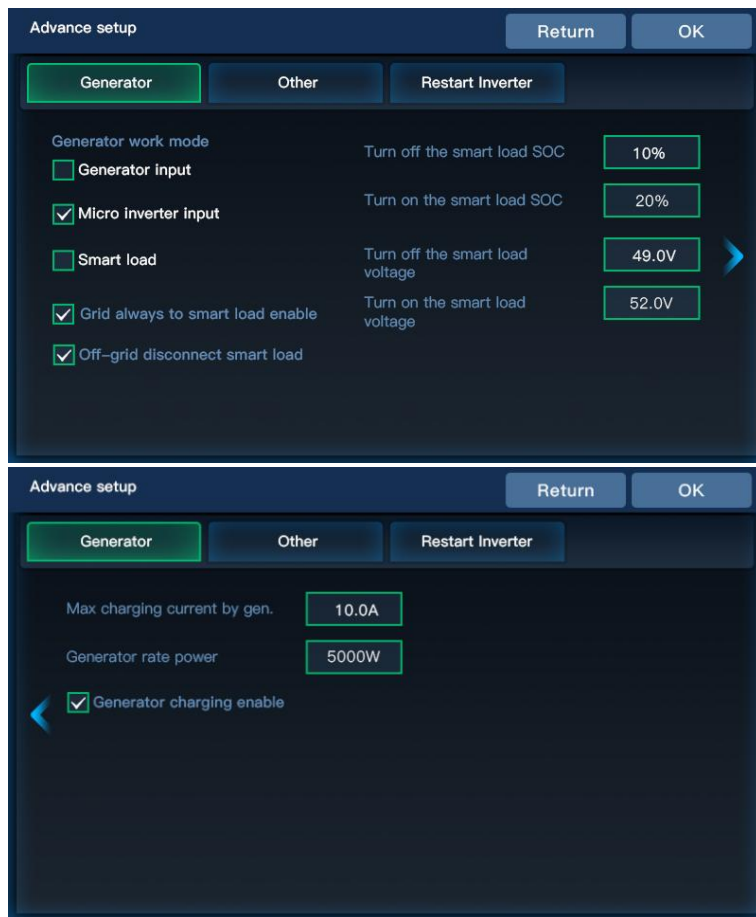

● Generator work mode:

- ① **Generator input:** When the generator is connected to the "Gen port", select the generator input.
- ② **Micro inverter input:** Select "Microinverter Input" when the grid-tied inverter is connected to the "Gen Port" of the hybrid inverter.
- ③ **Smart load:** Select "Smart Load Output" when the load is connected to the "Generation Port".
- ④ **Grid always to smart load enable:** When this option is enabled, the grid will continuously power the smart load. Otherwise, when the battery fails to meet the power supply demand, the smart load will be disconnected.
- ⑤ **Off-grid disconnect smart load:** When this option is enabled, the smart load will be disconnected at the moment the system switches to off-grid mode. Otherwise, the system will continue to power the smart load in off-grid status.

- **Turn off the smart load SOC:** When the battery SOC value is lower than the set value, the smart load disconnects (effective when communicating with BMS).
- **Turn on the smart load SOC:** When the battery SOC value is higher than the set value, the smart load connection is enabled (effective during BMS communication).
- **Turn off the smart load voltage:** When the battery voltage falls below this setting, the smart load disconnects (effective when there is no BMS communication).
- **Turn on the smart load voltage:** When the battery voltage is higher than the setting, the smart load connection is enabled (effective when there is no BMS communication).
- **Max. charging current by gen.:** Maximum battery charging current during generator charging.
- **Generator rate power:** Rated power of the generator. When the inverter uses the generator for load or charging, it dynamically adjusts the charging power to keep the power consumption below the rated power of the generator.
- **Generator charging enable:** Setting whether the generator is charged or not.

5.2.5.2 Other

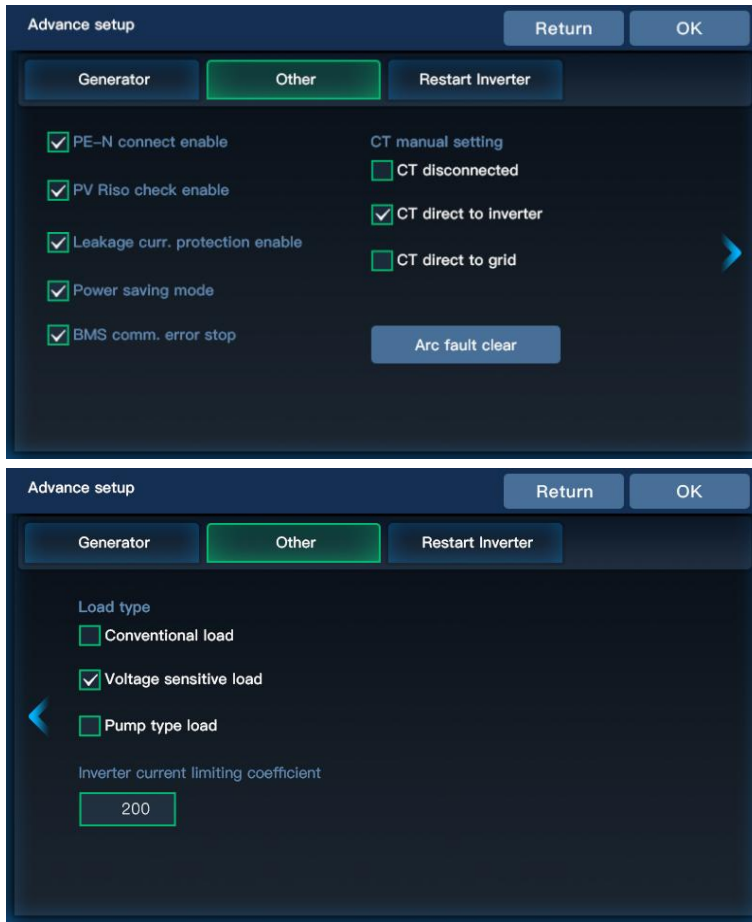

- **PE-N connect enable:** Enable PE-N connection.
- **PV Riso check enable:** Enable photovoltaic insulation impedance detection.
- **Leakage curr. protection enable:** Enable leakage current protection.
- **Power saving mode:** When the energy-saving mode is enabled,
 - ① If the load is no-load or less than 25W, the inverter output will turn off after a 5-minute delay.
 - ② If the load exceeds 40W, the inverter will automatically start.
 In grid-connected hybrid mode without PV input, when the energy-saving mode is enabled, the system's power loss is supplied by the battery. When the energy-saving mode is disabled, the system's power loss is supplied by the grid.
- **BMS comm. error stop:** When a BMS communication error occurs, the inverter stops outputting.

- **CT manual setting:** Select the direction of the CT according to the installation of the CT.
 - **load type:** Select the load type according to the connected load.
- Inverter Current Limiting coefficient:** Adjust the current coefficient when the inverter is soft-started (this setting is not recommended to be modified by the customer).

5.2.5.3 Restart Inverter

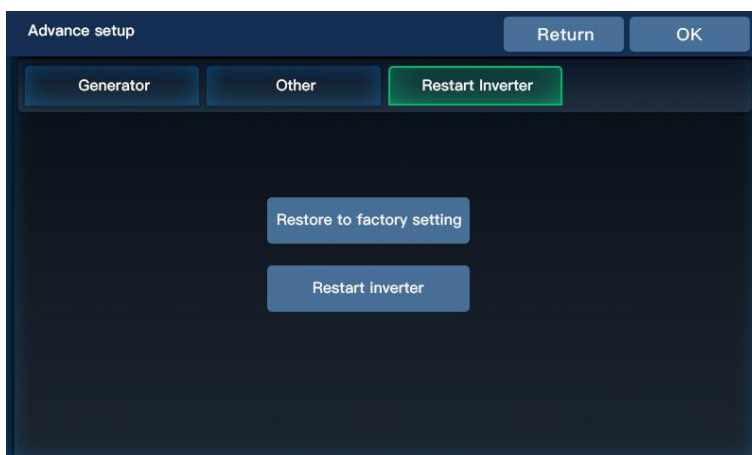

- **Restore to factory:** Reset all inverter settings.
- **Restart inverter:** Restart the inverter.



5.3 Time-slot Charging and Discharging Function

The HESP series is equipped with time-of-use charging and discharging functions, allowing users to set different charging and discharging periods according to the local peak-valley electricity prices, thereby making rational use of municipal electricity and photovoltaic power. When the price of municipal electricity is high, the battery inverter is used to power the loads; when the price of municipal electricity is low, the municipal electricity is used to power the loads and charge the battery. This helps users save electricity costs to the greatest extent.

The following examples are provided to help users understand its functions.

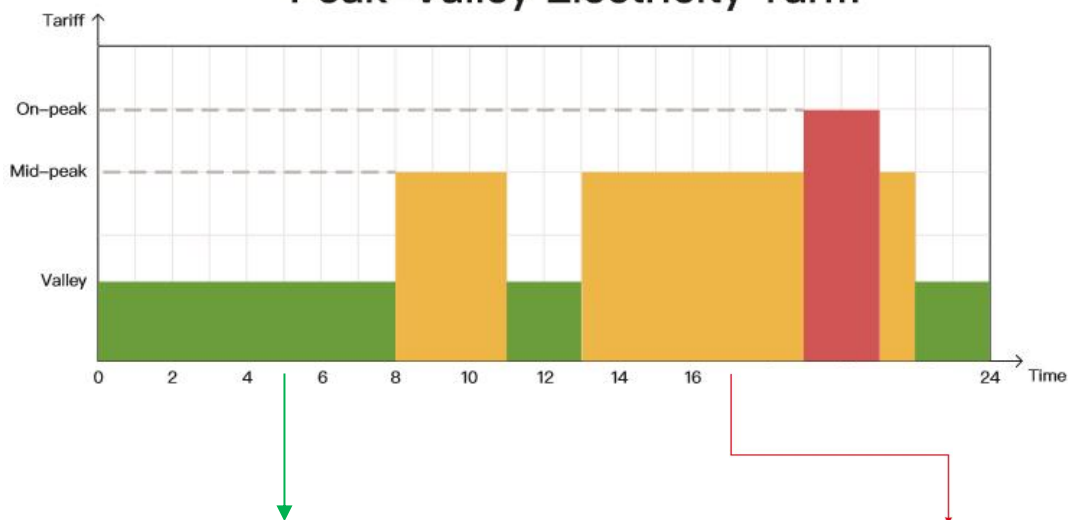
Peak-Valley Electricity Tariff



Time-slot Utility Charging & Loading Function	Time-slot Battery Discharging Function
	
<p>With 3 definable periods, the user can freely set the mains charging/supplying power time within the range of 00:00 to 23:59. During the time period set by the user, if PV energy is available, PV energy will be used first, and if PV energy is not available or insufficient, utility energy will be used as a supplement.</p>	<p>With 3 definable time periods, users can freely set the battery discharge time within the range of 00:00 to 23:59. During the time set by the user, the inverter will give priority to the battery inverter to carry the load, and if the battery power is insufficient, the inverter will automatically switch to mains power to ensure stable operation of the load.</p>

5.4 Battery Parameters

5.4.1 Lead-Acid Battery

Battery type Parameters	Sealed lead acid battery (SLD)	Gel lead acid battery (GEL)	Flooded lead acid battery (FLD)	User-defined (USE)	Adjustable
Overvoltage Disconnect Voltage	60V	60V	60V	60V	
Battery fully charged recovery point	52V	52V	52V	52V	√
Boost Charging Voltage	57.6	57.6	57.6	40 ~ 60V	√
Undervoltage Alarm Voltage	44V	44V	44V	40 ~ 60V	√
Undervoltage Alarm Recovery Voltage	Undervoltage alarm voltage+0.8V				
Low Voltage Disconnect Voltage	42V	42V	42V	40 ~ 60V	√
Low Voltage Disconnect Recovery Voltage	52V	52V	52V	52V	√
Discharge Limit Voltage	-	-	-	40 ~ 60V	√
Over-discharge Delay Time	5s	5s	5s	1 ~ 30s	√
Boost Charge Duration	-	-	-	10 ~ 600min	√

5.4.2 Lithium-ion Battery

Battery type Parameters	Ternary (N13)	Ternary (N14)	LFP (L16)	LFP (L15)	LFP (L14)	Adjustable
Overvoltage Disconnect Voltage	60V	60V	60V	60V	60V	
Battery Fully Charged Recovery Point	50.4V	54.8V	53.6V	50.4V	47.6V	√
Equalization Charging Voltage	-	-	-	-	-	√
Boost Charging Voltage	53.2V	57.6V	56.8V	53.2V	49.2V	√
Undervoltage Alarm Voltage (Fault 01)	43.6V	46.8V	49.6V	46.4V	43.2V	√
Undervoltage Alarm Recovery Voltage(Fault 01)	Undervoltage alarm voltage+0.8V					
Low Voltage Disconnect Voltage(Fault 04)	38.8V	42V	48.8V	45.6V	42V	√
Low Voltage Disconnect Recovery Voltage(Fault 04)	46V	49.6V	52.8V	49.6V	46V	√
Discharge Limit Voltage	36.4V	39.2V	46.4V	43.6V	40.8V	√
Over-discharge Delay Time	30s	30s	30s	30s	30s	√
Boost Charge Duration	120min	120min	120min	120min	120min	√

6. Communication

6.1 Product Overview

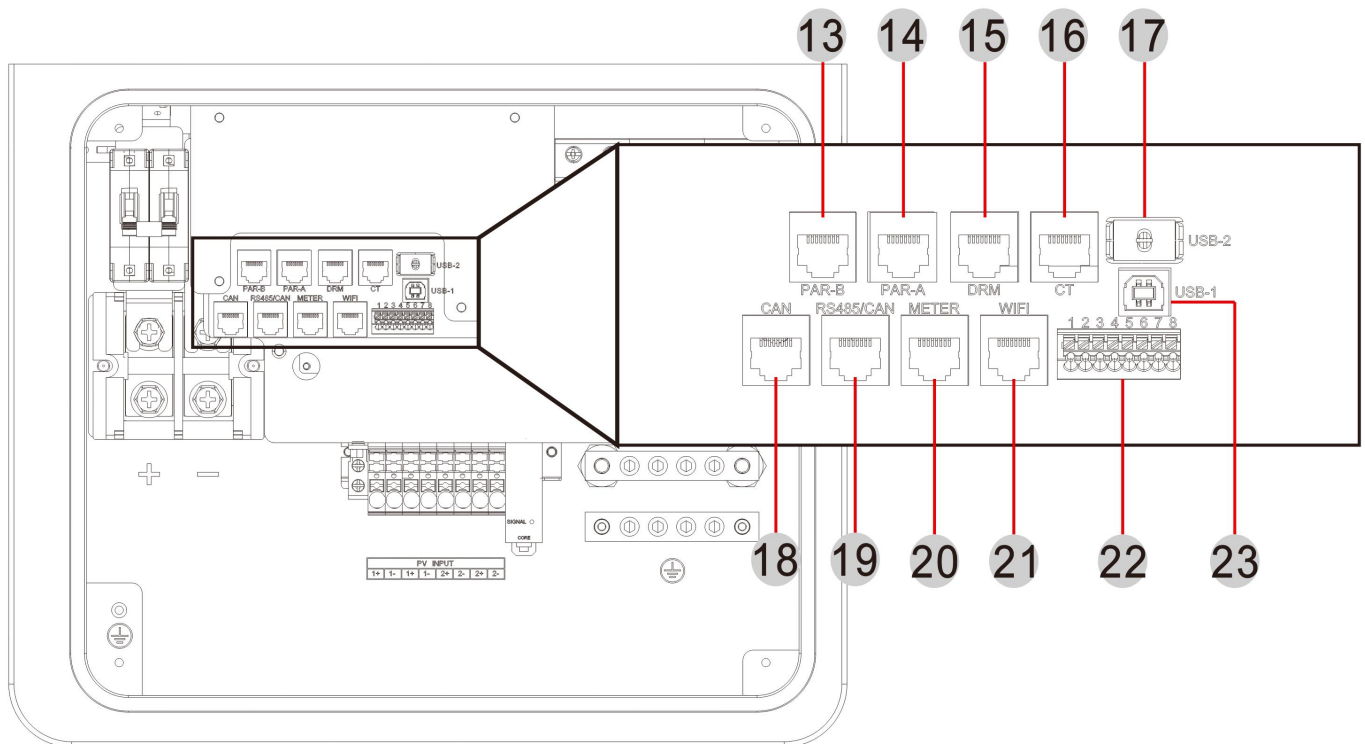

13	Parallel B	14	Parallel A	15	DRM
16	CT Port	17	USB-2 Display Port	18	CAN Port
19	RS485/CAN Communication	20	Electricity meter Port	21	WiFi Port
22	Dry contact	23	USB-1 Communication		

6.2 RS485/CAN Communication Function

- 1.The RS485/CAN communication port supports RS485 protocol communication with lithium battery BMS systems.
- 2.The RS485/CAN communication port supports CAN protocol communication with lithium battery BMS systems.

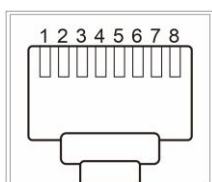

RS485/CAN

RJ45	Pin 1	Pin 2	Pin 3	Pin 4	Pin 5	Pin 6	Pin 7	Pin 8
Description	/	/	/	CANH	CANL	/	RS485-A	RS485-B

NOTICE

If you need to use the inverter to communicate with the lithium battery BMS, please contact us for the communication protocol or upgrade the inverter to the appropriate software programme.

6.3 CAN Function

The CAN port is used to connect to the BMS of Liion battery.

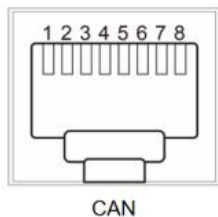

RJ45	Pin 1	Pin 2	Pin 3	Pin 4	Pin 5	Pin 6	Pin 7	Pin 8
Description	/	/	/	CANH	CANL	/	/	/

6.4 Dry Contact Function

The dry contact port has 3 functions :

- 1.RSD power supply
- 2.Temperature sampling (reserved)
- 3.Remote generator start/stop

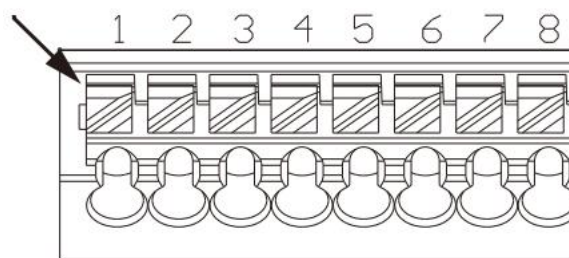

Function	Description
RSD power supply	PIN 1 is GND , PIN 2 is RSD 12V+
Temperature sampling (reserved)	Pin 1 & Pin 5 can be used for battery temperature sampling compensation.
Remote generator start/stop	<p>When the generator is connected, the following conditions must be met:</p> <ol style="list-style-type: none"> 1. Remotely start the generator when there is no grid connection; 2. When there is no BMS connection, remotely start the generator when the battery voltage is lower than the undervoltage alarm voltage or the battery switches to the grid voltage point; 3. When the BMS is connected, remotely start the generator when the battery SOC is lower than the set value of the battery-to-mains SOC set point; 4. When there is no BMS connection, remotely stop the generator when the battery voltage reaches the voltage point of the mains-to-battery switch or the battery is fully charged; 5. When the BMS is connected, remotely shut down the generator when the battery SOC is lower than the set value of the mains-to-battery SOC; 6. Remotely turn off the generator when the battery is fully charged; <p>Remote generator start: Pin 6 to Pin 7 is normally open, and Pin 6 to Pin 8 is normally closed.</p> <p>Remote generator stop: Pin 6 to Pin 7 is normally closed, and Pin 6 to Pin 8 is normally open.</p> <p>(The allowable voltage and current ranges for Pins 6/7/8 are 100Vac/1A, 200Vac/1A, and 30Vdc/1A respectively)</p>

 **NOTICE**

If you need to use the remote start/stop function of a dry contact generator, please ensure that the generator is equipped with an automatic transmitter and supports remote start/stop functions.

6.5 WiFi Communication Function

The WiFi communication port can be connected to the optional RS485-to-WIFI/GPRS communication module developed by our company. After installing this module, it can connect to our inverter, allowing users to view the inverter's operating status and parameters through a mobile APP.

■ WiFi Port 1 (either one)

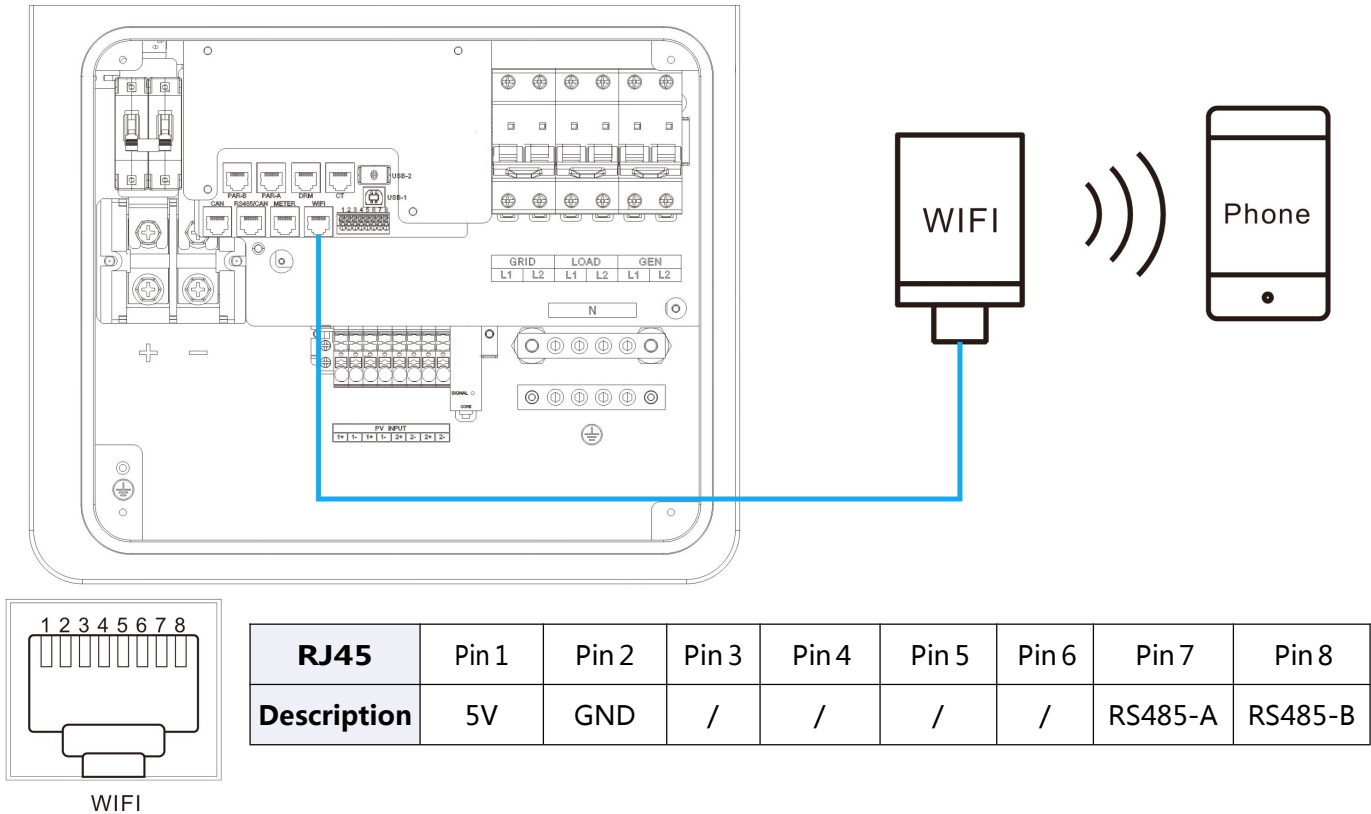

■ WiFi Port 2 (either one)

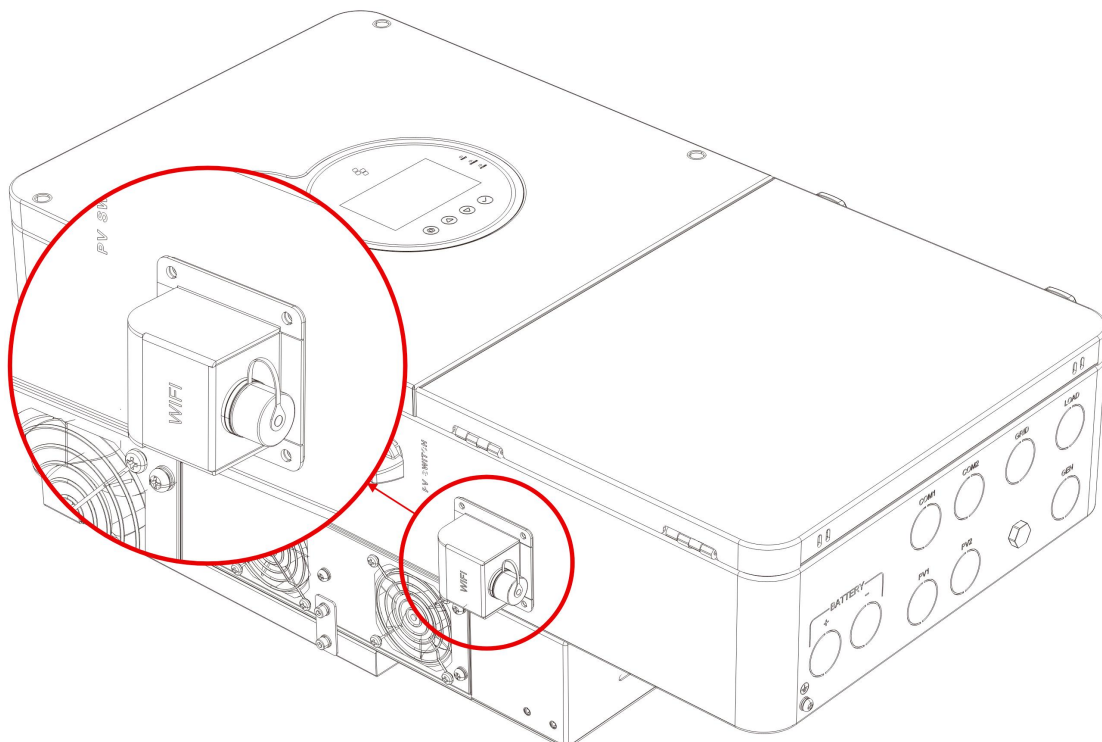

6.6 USB-1 Communication Function

This port is a USB communication port, which can be used for USB communication with our optional upper computer software (application required) via this port. To use this port, the corresponding "USB-to-serial port chip CH340T driver" must be installed on the computer.

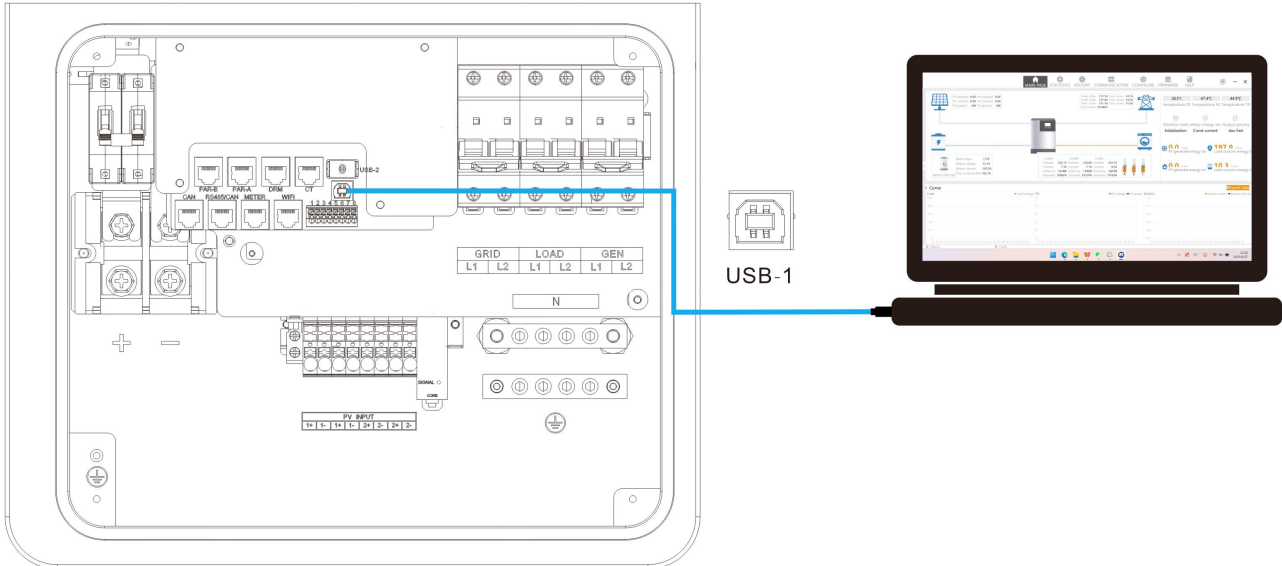

6.7 USB-2 Display Port

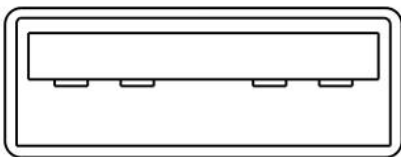

It is used to update the screen firmware.

6.8 DRM(Only Australia)

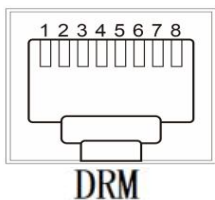

RJ45	Pin 1	Pin 2	Pin 3	Pin 4	Pin 5	Pin 6	Pin 7	Pin 8
Description	DRM5	DRM6	DRM7	DRM8	RefGen	COM/ DRM0	V+	V-

MODEL	RJ45 socket asserted by shorting pins		Requirement
DRM0	5	6	Operate the power-off device.
DRM5	1	5	Do not generate power to the grid.
DRM6	2	5	The power generation shall not exceed 50% of the rated power.
DRM7	3	5	The power generation shall not exceed 75% of the rated power, and reactive power shall be absorbed when possible.
DRM8	4	5	Increase power generation (limited by other active DRM).

6.9 Parallel Communication Function

This port is a parallel communication port, through which parallel modules can communicate with each other when connected.

1. Each device is equipped with two 8-pin parallel communication ports: PAR-A (Parallel Port A) and PAR-B (Parallel Port B).
2. For connection, connect the PAR-A (Parallel Port A) of the current device to the Parallel Port B of the device to be paralleled, or connect the PAR-B (Parallel Port B) of the current device to the Parallel Port A of the device to be paralleled.
3. Direct connection between the PAR-A and PAR-B of the same device is prohibited.

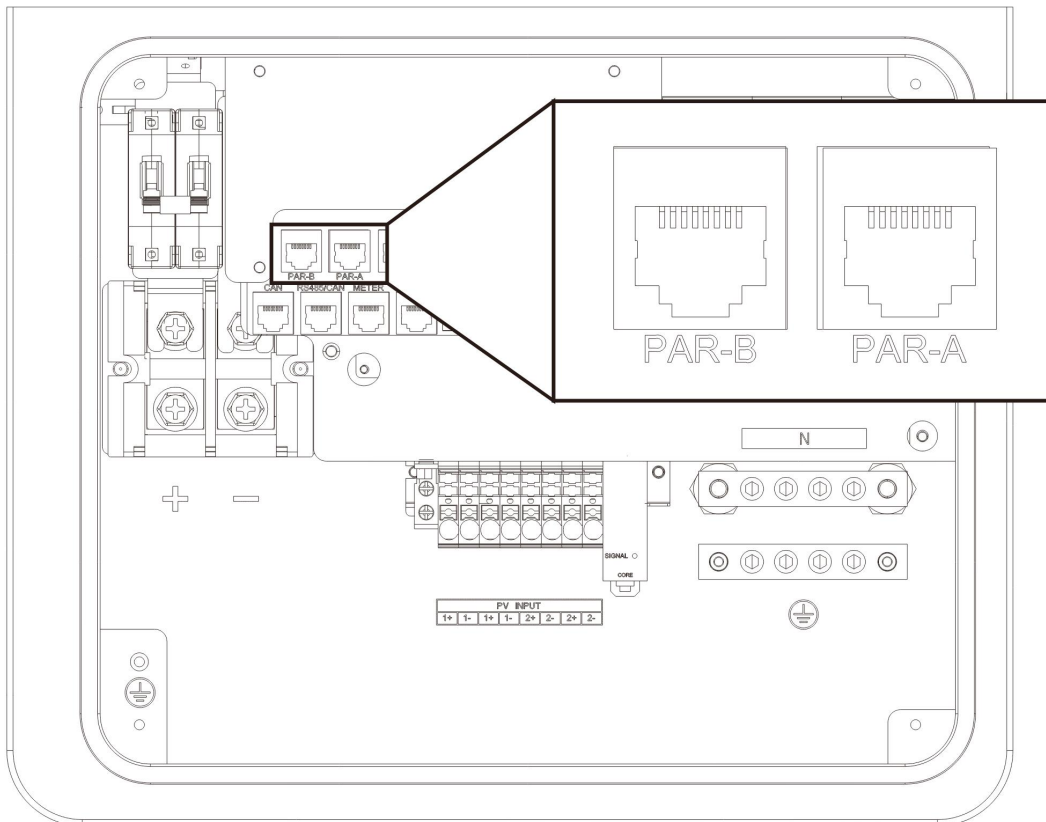

6.10 External CT Wiring

1. Current Transformer (CT) Dimensions: (mm)
2. Length of Secondary Output Cable: 4m
3. CT Direction Points to the Inverter

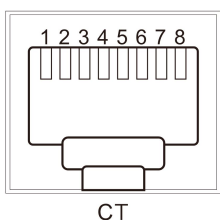

RJ45	Pin 1	Pin 2	Pin 3	Pin 4	Pin 5	Pin 6	Pin 7	Pin 8
Definition	CT3+	CT3-	/	CT2+	CT2-	/	CT1+	CT1-

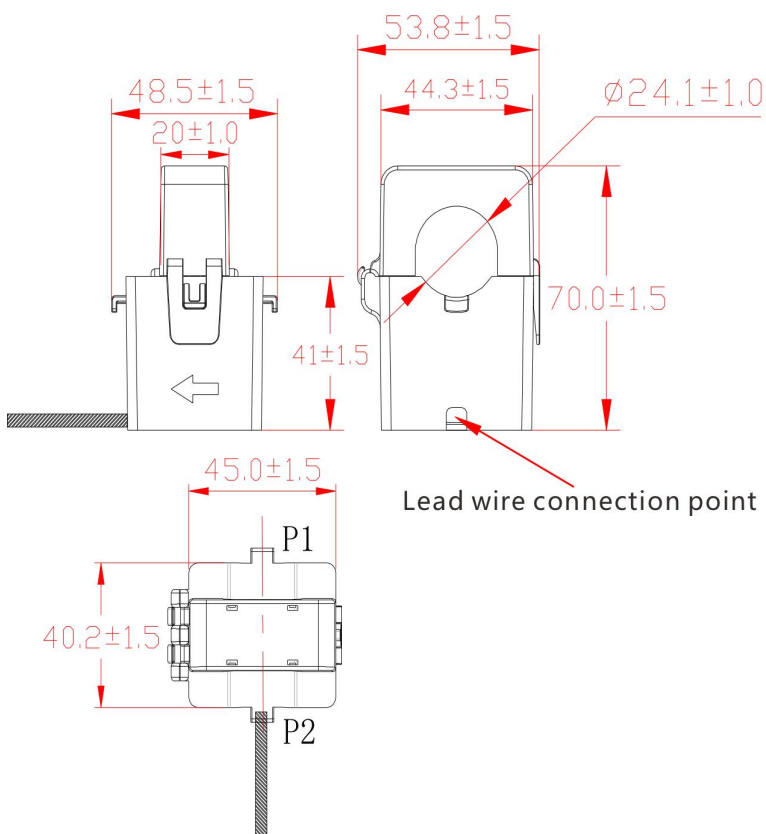
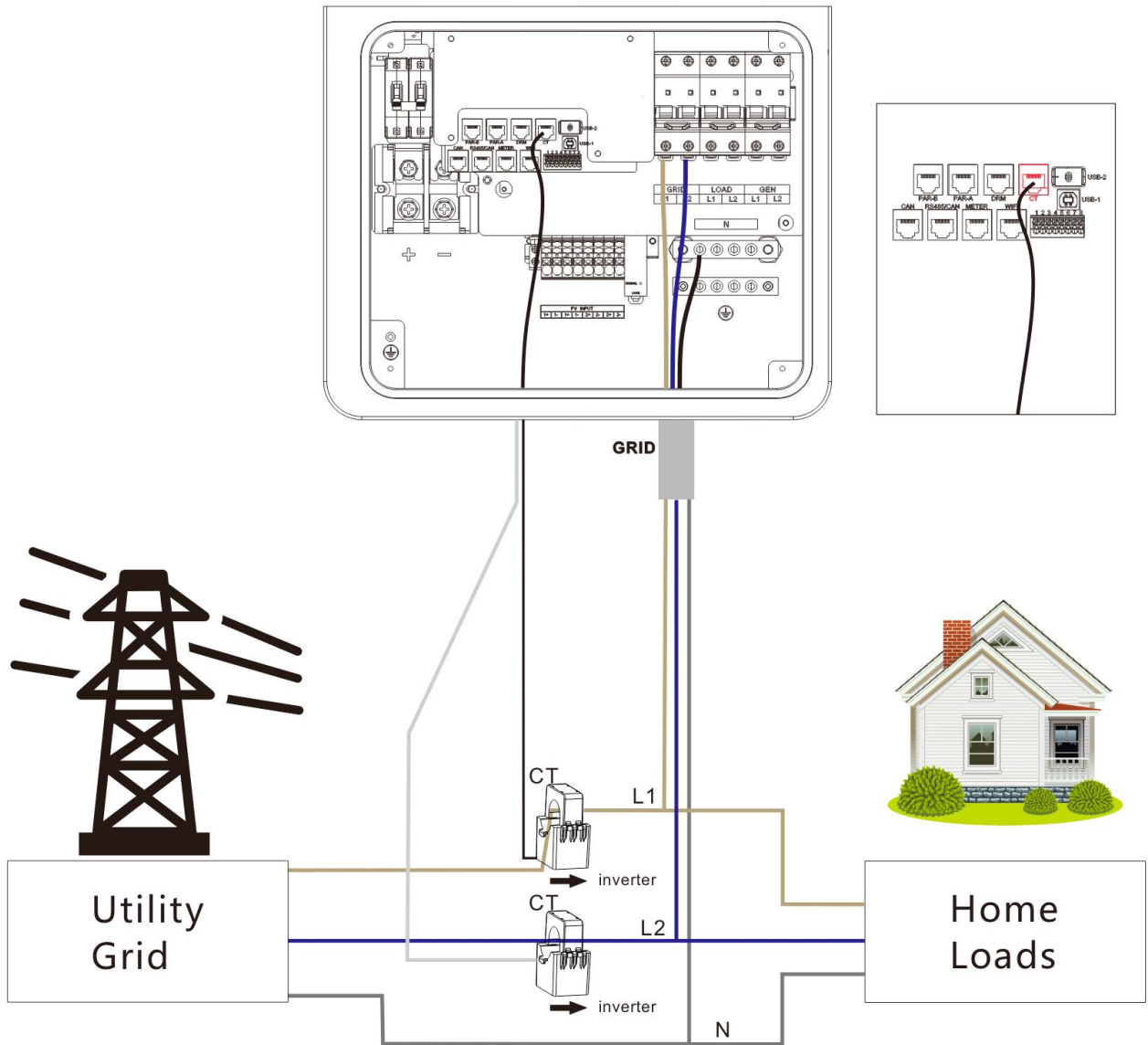

7. Fault Codes and Countermeasures

7.1 Fault Codes

Fault Code	Meaning	Impact on Output	Description
01	BatVoltLow	NO	Battery undervoltage alarm.
02	BatOverCurrSw	YES	Battery discharge average current overcurrent (software protection).
03	BatOpen	YES	Battery not-connected alarm.
04	BatLowEod	YES	Battery undervoltage stop discharge alarm.
05	BatOverCurrHw	YES	Battery overcurrent (hardware protection).
06	BatOverVolt	YES	Charging overvoltage protection.
07	BusOverVoltHw	YES	Bus overvoltage (hardware protection).
08	BusOverVoltSw	YES	Bus overvoltage (software protection).
09	PvVoltHigh	NO	PV overvoltage protection.
10	PvBoostOCSw	NO	Boost overcurrent (software protection).
11	PvBoostOCHw	NO	Boost overcurrent (hardware protection).
13	OverloadBypass	YES	Bypass overload protection.
14	OverloadInverter	YES	Inverter overload protection.
17	InvShort	YES	Inverter short-circuit protection.
19	OverTemperMppt	NO	PV radiator over-temperature protection.
20	OverTemperInv	YES	Inverter radiator over-temperature protection.
21	FanFail	YES	Fan fault.
22	EEPROM	YES	Memory fault.
23	ModelNumErr	YES	Model setting error.
26	Rlyshort	YES	Inverter AC Output Backfeeding to Bypass AC Output.
29	BusVoltLow	YES	Bus voltage undervoltage protection.
30	BatCapacityLow1	NO	Alarm when the battery capacity rate is below 10% (BMS enable validity setting required).
31	BatCapacityLow2	NO	Alarm when the battery capacity rate is below 5% (BMS enable validity setting required).
32	BatCapacityLowStop	YES	Battery low-capacity shutdown (BMS enable must be set valid).
34	CanCommFault	YES	Parallel CAN communication failure.
35	ParaAddrErr	YES	Parallel machine ID (communication address) setting error.
37	ParaShareCurrErr	YES	Parallel current sharing failure.

38	ParaBattVoltDiff	YES	Parallel mode, large battery voltage difference.
39	ParaAcSrcDiff	YES	Parallel mode, inconsistent mains input sources.
40	ParaHwSynErr	YES	Parallel mode, hardware synchronization signal failure.
41	InvDcVoltErr	YES	Abnormal DC component of inverter voltage.
42	SysFwVersionDiff	YES	Inconsistent parallel machine program versions.
43	ParaLineContErr	YES	Parallel wiring failure.
44	Serial number error	YES	Factory-set serial number not configured.
45	Error setting of split-phase mode	YES	Incorrect setting of parallel mode parameters.
46	Meter communication error	YES	Abnormal wiring: Check whether the electricity meter communication line connection is correct and whether the electricity meter communication address is set properly.
49	Grid over voltage	YES	Grid voltage too high.
50	Grid under voltage	YES	Grid voltage too low.
51	Grid over Frequency	YES	Grid voltage frequency too high.
52	Grid under Frequency	YES	Grid voltage frequency too low.
53	Grid loss	YES	Grid voltage loss.
54	Grid DC current over	YES	Grid current DC component too high.
55	Grid standard un init	YES	Grid-connection standard micro-initialization.
56	Low insulation resistance fault	NO	The ground - impedance of PV1+, PV2+, PV3+, PV4+ and PV - is abnormally low.
57	Leakage current overload fault	YES	System leakage current exceeds the standard.
58	BMSComErr	NO	BMS communication failure.
60	BMSUnderTem	NO	BMS low-temperature alarm (takes effect after successful BMS communication).
61	BMSOverTem	YES	BMS over-temperature alarm (takes effect after successful BMS communication).
62	BMSOverCur	YES	BMS over-current alarm (takes effect after successful BMS communication).
63	BMSUnderVolt	NO	BMS under-voltage alarm (takes effect after successful BMS communication).

7.2 Partial Troubleshooting

Fault Code	Meaning	Cause
Display	No display on the screen	Check if the battery switch or PV switch is closed; whether the switch is in the "ON" state; press any button on the screen to exit the screen sleep mode.
[06]	Battery overvoltage protection	Check that the battery voltage does not exceed the protection value. If it does, discharge the battery until the voltage falls below the battery over-voltage recovery point.
[01] [04]	Battery undervoltage protection	Charge the battery until it returns to the low voltage disconnection recovery voltage.
[21]	Fan failure	Check if the fan is not turning or blocked by foreign object.
[19] [20]	Heat sink over temperature protection	When the temperature of the device is cooled below the recovery temperature, normal charge and discharge control is resumed.
[13] [14]	Bypass overload protection, inverter overload protection	1.Reduce electrical equipment; 2.Restart the all-in-one machine, and the load will resume output. 3.Carefully check the load connection and remove the short-circuit fault point;
[17]	Inverter short-circuit protection	4.Power on again, and the load will resume output.
[09]	PV overvoltage	Use a multimeter to check if the PV input voltage exceeds the maximum allowable input voltage rated.
[03]	Battery disconnection alarm	
[40] [43]	Parallel connection fault	Check if the battery is not connected or if the battery circuit breaker is not closed.
[35]	Parallel ID setting error	Check whether the setting of parallel ID number is repeated.
[37]	Parallel current sharing fault	Check if the parallel current sharing line is not connected well, such as loose or wrong connection.
[39]	Parallel Mode, Grid input source inconsistent	Check whether the parallel AC inputs are from the same input interface.
[42]	Inconsistent system firmware version in parallel mode	Check whether the software version of each inverter is consistent.
[44]	Serial number error	Incorrect device serial number setting.
[45]	Parallel mode error	There is a device in the parallel system with the wrong parallel mode setting.
[49]	High grid voltage	Check that the grid voltage is within the normal range, if the grid voltage is abnormal, wait until the grid voltage is restored.
[50]	Low grid voltage	Check that the grid voltage is within the normal range, if the grid voltage is abnormal, wait until the grid voltage is restored.
[51]	High grid frequency	Check that the grid frequency is within the normal range, if the grid frequency is abnormal, wait until the grid frequency is restored.
[52]	Low grid frequency	Check that the grid frequency is within the normal range, if the grid frequency is abnormal, wait until the grid frequency is restored.
[53]	Grid unconnected	Check if the grid is correctly connected, e.g. if the switch is closed and if the grid is disconnected.

【54】	Grid-connected current with DC component over	Power down and restart the device, if it continues to report faults, contact the manufacturer after sales.
【56】	Low insulation resistance fault	Check that the system is well grounded and that the PV modules and cables are not worn.
【57】	Leakage current overload fault	Check that the system is well grounded and that the loads are not operating abnormally.

 **NOTICE**

If you encounter a fault with the product that cannot be solved by the methods in the table above, please contact our after-sales service for technical support and do not disassemble the equipment yourself.

8. Protection and Maintenance

8.1 Protection Functions

No.	Protection Functions	Definition
1	PV input current/power limiting protection	When the charging current or power of the PV array configured exceeds the PV input rated value, the inverter will limit the input power and charge at the rated.
2	PV input over-voltage	If the PV voltage exceeds the maximum value allowed by the hardware, the machine will report a fault and stop the PV boost to output a sinusoidal AC wave.
3	PV night reverse current protection	At night, the battery is prevented from discharging through the PV module because the battery voltage is greater than the voltage of PV module.
4	AC input over-voltage protection	When the mains voltage exceeds 280Vac (L1-L2), mains charging will stop and the inverter will switch to output mode.
5	AC input under-voltage protection	When the mains voltage falls below 130Vac (L1-L2), mains charging will stop and the inverter will switch to output mode.
6	Battery over-voltage protection	When the battery voltage reaches the over-voltage cut-off point, the PV and the utility will automatically stop charging to prevent the battery from being overcharged and damaged.
7	Battery under-voltage protection	When the battery voltage reaches the under-voltage cut-off point, the inverter will automatically stop the battery discharge to prevent damage from over-discharging the battery.
8	Battery over-current protection	After a period when the battery current exceeds that allowed by the hardware, the machine will switch off the output and stop discharging the battery.
9	AC output short-circuit protection	When a short-circuit fault occurs at the load output for more than 200ms, the AC output will be immediately turned off, and then manually re-powered on to restore normal output. (Not in the bypass mode)

10	Heat sink over-temperature protection	When the internal temperature of the inverter is too high, the inverter will stop charging and discharging; when the temperature returns to normal, the inverter will resume charging and discharging.
11	Overload Protection	After triggering overload protection, the inverter will resume output after 3 minutes. If overload occurs 5 consecutive times, the output will be turned off until the inverter is restarted. (102% < load < 110%) : Alarm, output off after 5 minutes. (111% < Load < 125%) : Alarm, output off after 1 minute. (126% < load < 150%) : Alarm, output off after 30 seconds. (151% < Load < 200%) : Alarm, output off after 10 seconds.
12	AC output reverse	Prevents AC back flow from the battery inverter to the bypass AC input.
13	Bypass over-current protection	Built-in AC input over-current protection circuit breaker.
14	Bypass Wiring Error Protection	When the phase of the two bypass inputs is different from the phase of the inverter phase split, the machine will prohibit cutting into the bypass to prevent the load from dropping out or shorting out when cutting into the bypass.

8.2 Maintenance

To maintain optimal long-term performance, it is recommended to perform the following inspections twice a year for inverter systems:

1. Ensure that the airflow around the inverter is not blocked and remove any dirt or debris from the radiator.
2. Check that all exposed conductors are not damaged by sunlight, friction with other surrounding objects, dry rot, insect or rodent damage, etc. The conductors need to be repaired or replaced if necessary.
3. Verify that the indications and displays are consistent with the operation of the equipment, note any faults or incorrect displays and take corrective action if necessary.
4. Check all terminals for signs of corrosion, insulation damage, high temperatures or burning/discolouration and tighten terminal screws.
5. Check for dirt, nesting insects and corrosion, clean as required, Clean the insect screen regularly.
6. If the lightning arrester has failed, replace the failed arrester in time to prevent lightning damage to the inverter or other equipment of the user.

 **DANGER**

Make sure that the inverter is disconnected from all power sources and that the capacitors are fully discharged before carrying out any checks or operations to avoid the risk of electric shock.

The Company shall not be liable for damage caused by :

1. Damage caused by improper use or use in a wrong location.
2. Photovoltaic modules with an open circuit voltage exceeding the maximum permissible voltage.
3. Damage caused by the operating temperature exceeding the restricted operating temperature range
4. Dismantling and repair of the inverter by unauthorised persons.
5. Damage caused by force majeure: damage during transport or handling of the inverter.

9. Datasheet

Model	HESP series				
	4840U120-HUS	4850U120-HUS	4860U140-HUS	4865U140-HUS	Settable
AC Output					
Rated Output Power	4000W	5000W	6000W	6500W	
Single-phase unbalanced output power	4000W	4500W	4500W	4500W	
Max. Apparent Power	4400VA	5500VA	6600VA	7000VA	
Max. Peak Power	2 times of rated power, 10s				
Rated Output Voltage	120/240Vac(split phase); 120/208V(three phase)				√
Rated Output Current	16.6A @240V 19.2A @208V	20.9A @240V 4A @208V 2	25A @240V 28.8A @208V	27.1A @240V 31.3A @208V	
Rated Frequency	50/60Hz				√
Waveform	Pure sine wave				
Switch Time	10ms (Typical)				
THD	< 3%				
Battery					
Battery Type	Lithium-ion Battery / Lead-acid Battery / User-defined				√
Rated Battery Voltage	48Vdc				
Battery Voltage Range	40-60Vdc				√
Max. Discharging Current	120A		140A		
Max. PV Charging Current	120A		140A		√
Max. Grid Charging Current	120A		140A		√

Max. Generator Charging Current	120A	140A	√
Max. Hybrid Charging Current	120A	140A	√
PV Input			
No. of MPPT Trackers	2		
Max. PV Input Power	6000W + 6000W		
Max. PV Input Current	32A+32A		
Max. Open Circuit Voltage	600Vdc / 600Vdc		
MPPT Operating Voltage Range	120-500Vdc / 120-500Vdc		
Grid/Generator Input			
Input Voltage Range	65-140Vac		
Input Frequency Range	50/60Hz		
Bypass Overload Current	60A		
Efficiency			
MPPT Tracking Efficiency	99.9%		
Max. Efficiency	97.6%		
CEC Efficiency	96.5%		
General Data			
Parallel Capacity	1-6 Units		
Dimensions (W × H × D)	400x760x250mm		
Weight	42kg		
Protection Class	IP65		
Operating Temperature	-40~60°C, >45°C derated		
Noise	<60dB		
Cooling Method	Heat sink + intelligent air cooling		
Communication Interface	RS485 / CAN / USB / Dry contact		√
External Modules	Wi-Fi / GPRS (Optional)		√
Certification			
Safety	IEC 62109-1/-2, EN 61000, UL1741, CSA C22.2		
EMC	FCC 15 class B		
RoHS	Yes		

SRNE Solar Co.,Ltd

Mail service@szshuori.com

Web www.srnesolar.com

Address 4-5F,Building13A,Taihua Wutong
Industrial Park ,Gushu Development
Zone , Hangcheng Street,Baoan,
Shenzhen, China PR
