

# Solar Storage Inverter

## User manual

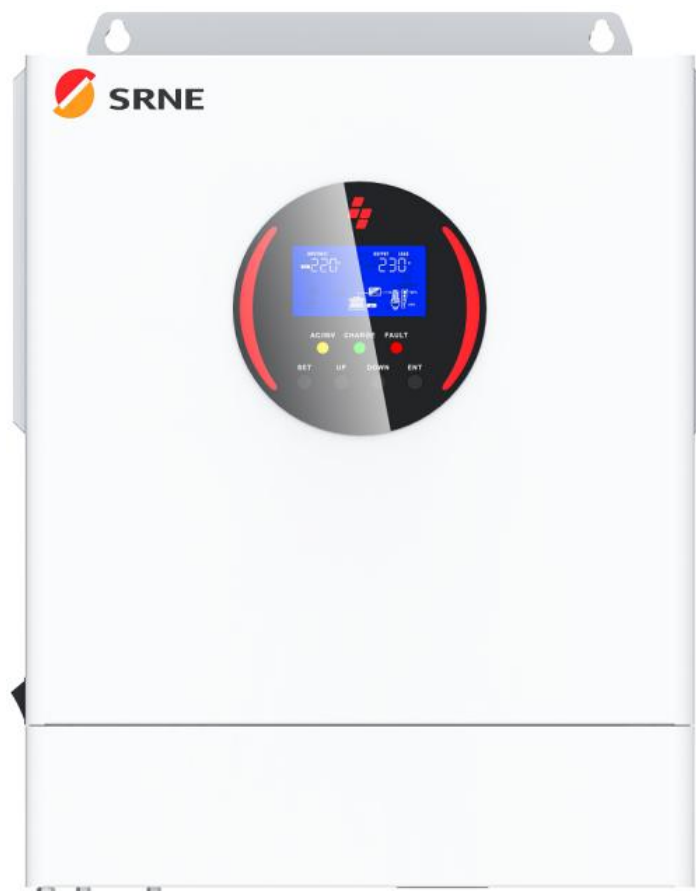

**Product Model:**

AFP4850S100-H

## Important Safety Instructions

### *Keep this manual for future reference!*

This manual contains all safety, installation and operating instructions for the AFP Series Solar Energy Storage Inverter Control Unit.

Please read all instructions and cautions in this manual carefully before installation and use.

- Non-safety voltage exists inside the all-in-one solar charge inverter. To avoid personal injury, users shall not disassemble the all-in-one solar charge inverter themselves. Contact our professional maintenance personnel if there is a need for repair.
- Do not place the all-in-one solar charge inverter within the reach of children.
- Do not install the all-in-one solar charge inverter in harsh environments such as moist, oily, flammable or explosive, or heavily dusty areas.
- The grid input and AC output are high voltage, so please do not touch the wiring terminals.
- The housing of the all-in-one solar charge inverter is hot when it is working. Do not touch it.
- Do not open the terminal protective cover when the all-in-one solar charge inverter is working.
- It is recommended to attach proper fuse or circuit breaker to the outside of the all-in-one solar charge inverter.
- Always disconnect the fuse or circuit breaker near the terminals of PV array, grid and battery before installing and adjusting the wiring of the all-in-one solar charge inverter.
- After installation, check that all wire connections are tight to avoid heat accumulation due to poor connection, which is dangerous.
- The all-in-one solar charge inverter is off-grid. It is necessary to confirm that it is the only input device for load, and it is forbidden to use it in parallel with other input AC power to avoid damage.

# Table of Contents

1. Basic information .....	1
1.1 Product overview and characteristics .....	1
1.2 Basic system introduction .....	2
1.3 Production overview .....	3
1.4 Dimension drawing .....	4
2. Installation instruction .....	5
2.1 Installation precautions .....	5
2.2 Packing lists .....	6
2.4 Installation and wiring .....	8
2.5 Parallel machine wire connection .....	14
2.5.1 Introduction .....	14
2.5.2 Precautions for connecting the parallel connecting lines .....	14
2.5.3 Schematic diagram of parallel connection in single phase .....	17
2.5.4 Schematic diagram of parallel connection in three phase .....	20
3. Operating mode .....	25
3.1 Charge mode .....	25
3.2 Power supply mode .....	25
4. Operation instruction for LCD screen .....	27
4.1 Operation and display panel .....	27
4.2 Setting parameter .....	30
4.3 Battery type parameter table .....	35
5. Other function .....	37
5.1 Dry node function .....	37
5.2 RS485 communication function .....	37
5.3 USB communication function .....	37
5.4 USB communication function .....	37
6. Protection .....	38
6.1 Protection features available .....	38
6.2 Meaning of fault code .....	39
7. System maintenance .....	41
8. Technical parameter .....	42

# 1. Basic information

## 1.1 Product overview and characteristics

AFP series is a new hybrid solar energy storage inverter control all-in-one machine integrating solar energy storage & grid charging energy storage and AC sine wave output, which is controlled by DSP and features high response speed, high reliability and high industrialization standard through advanced control algorithm.

The solar charging module adopts the latest optimized MPPT tracking technology, which can quickly track to the maximum power point of the PV array in any environment and obtain the maximum energy of the solar panel in real time.

AC-DC charging module adopts advanced control algorithm to realize fully digitalized dual closed-loop control of voltage and current, with high control precision and small size. The AC voltage input range is wide, and the input/output protection functions are complete, which can realize charging and protection of the battery stably and reliably.

DC-AC inverter module is based on full-digital intelligent design and adopts advanced SPWM technology to output pure sinusoidal waveform, which converts DC into AC and is suitable for AC loads such as household appliances, power tools, industrial equipments, electronic audio-video, etc. The product adopts segment LCD display. The product adopts segmented liquid crystal display design, which shows the operation data and status of the system in real time. Comprehensive electronic protection function ensures that the whole system is safer and more stable.

### Features :

- It employs full - digital dual - closed - loop control of voltage and current along with advanced SPWM technology, delivering a pure sine - wave output.
- It offers two output modes, namely grid bypass and inverter output, enabling an uninterruptible power supply function.
- There are two selectable charging modes: solar - only charging and combined solar and grid charging.
- With advanced MPPT technology, it achieves a tracking efficiency of up to 99.9%.
- Featuring an LCD screen and three LED indicators, it dynamically displays system data and operating status.
- An ON/OFF rocker switch is used to control the AC output.
- It is equipped with a power - saving mode, which reduces no - load losses.
- An intelligent adjustable - speed fan is adopted for efficient heat dissipation and to extend the system's lifespan.
- It comes with a built - in function to activate lithium batteries using solar energy and grid power, and supports the connection of both lead - acid and lithium batteries.

- It is equipped with multiple protection functions, providing 360° all - around protection.
- It has comprehensive protection features, including short - circuit protection, over - and under - voltage protection, overload protection, and reverse - current protection.

## 1.2 Basic system introduction

The figure below shows the system application scenario of this product. A complete system includes the following parts:

**A. PV module:** convert the light energy into direct current energy and then charge the battery via the all-in-one machine, or directly invert the light energy into alternating current to supply power to the load.

**B. Grid or generator:** connected at the AC input, it can supply power to the load and charge the battery at the same time. If no grid power or generator is connected, the system can also operate normally. At this time, the load power is supplied by the battery and photovoltaic modules.

**C. Battery:** the battery is to ensure the normal power consumption of the system load in case of no sufficient solar energy or grid supply.

**D. Household load:** it can be connected to various household and office loads, including AC loads such as refrigerators, lamps, televisions, fans, air conditioners, etc.

**E. Solar inverting:** the energy conversion device of the whole system.

The specific system wiring mode is determined by the actual application scenario.

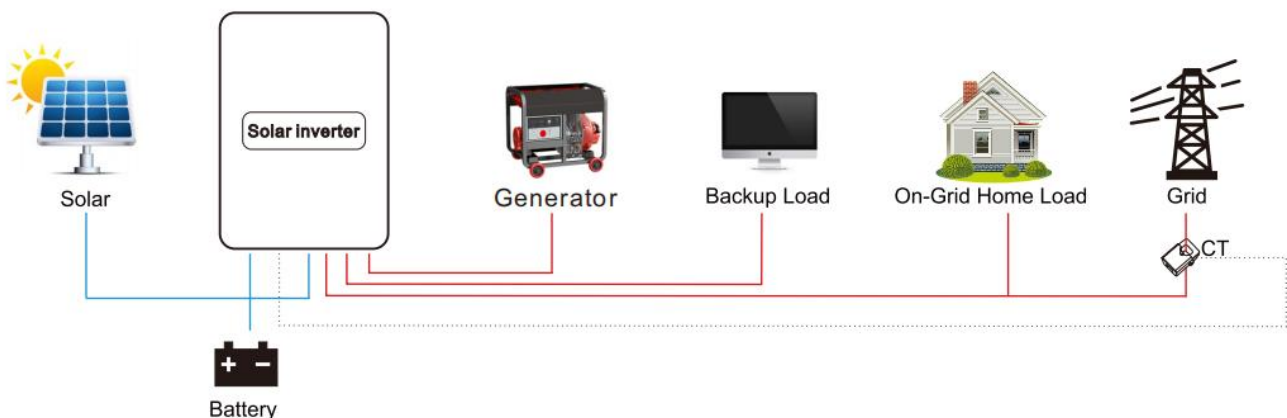

### 1.3 Production overview

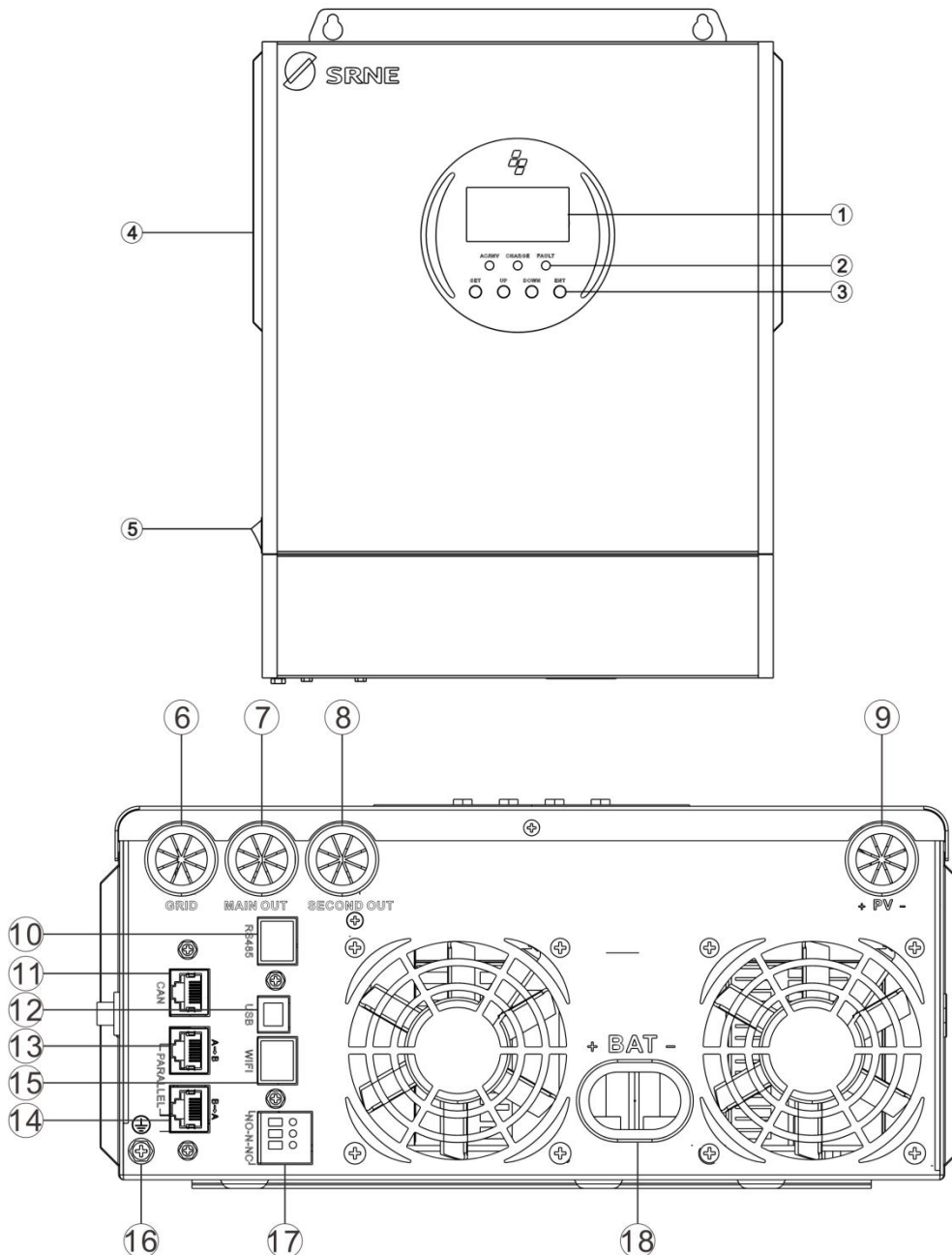

1	LCD Display	2	LED indicator light
3	Push button	4	Insect-proof net
5	Boat switch	6	AC input port
7	Main load output port	8	Secondary load output port
9	PV input port	10	RS485 communication port
11	USB communication port	12	WIFI communication port
13	Ground screw	14	Dry junction
15	Battery port	10	Ground screw
17	Dry contact	18	Battery port

## 1.4 Dimension drawing

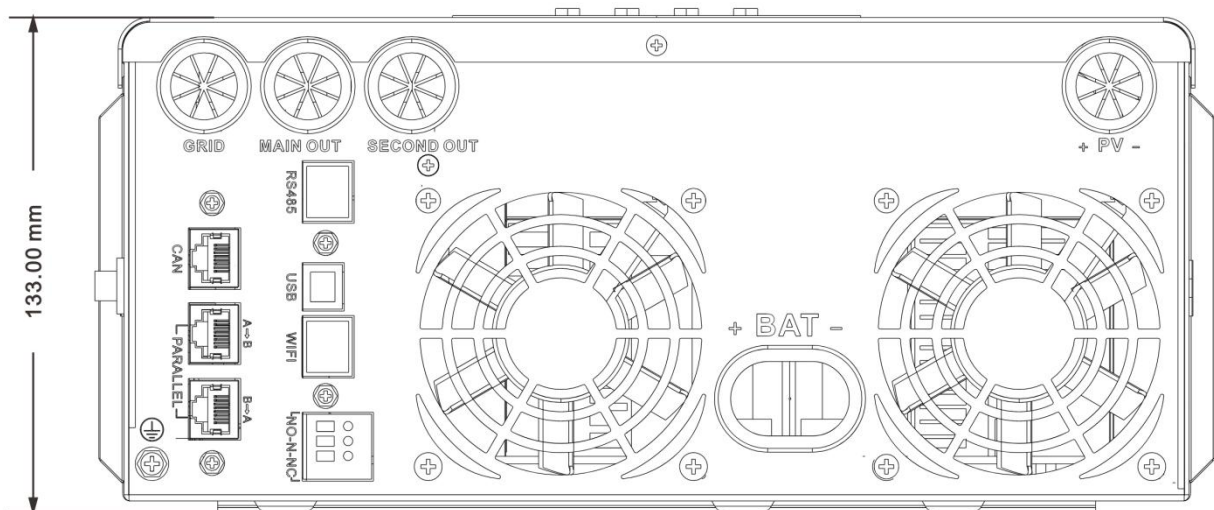
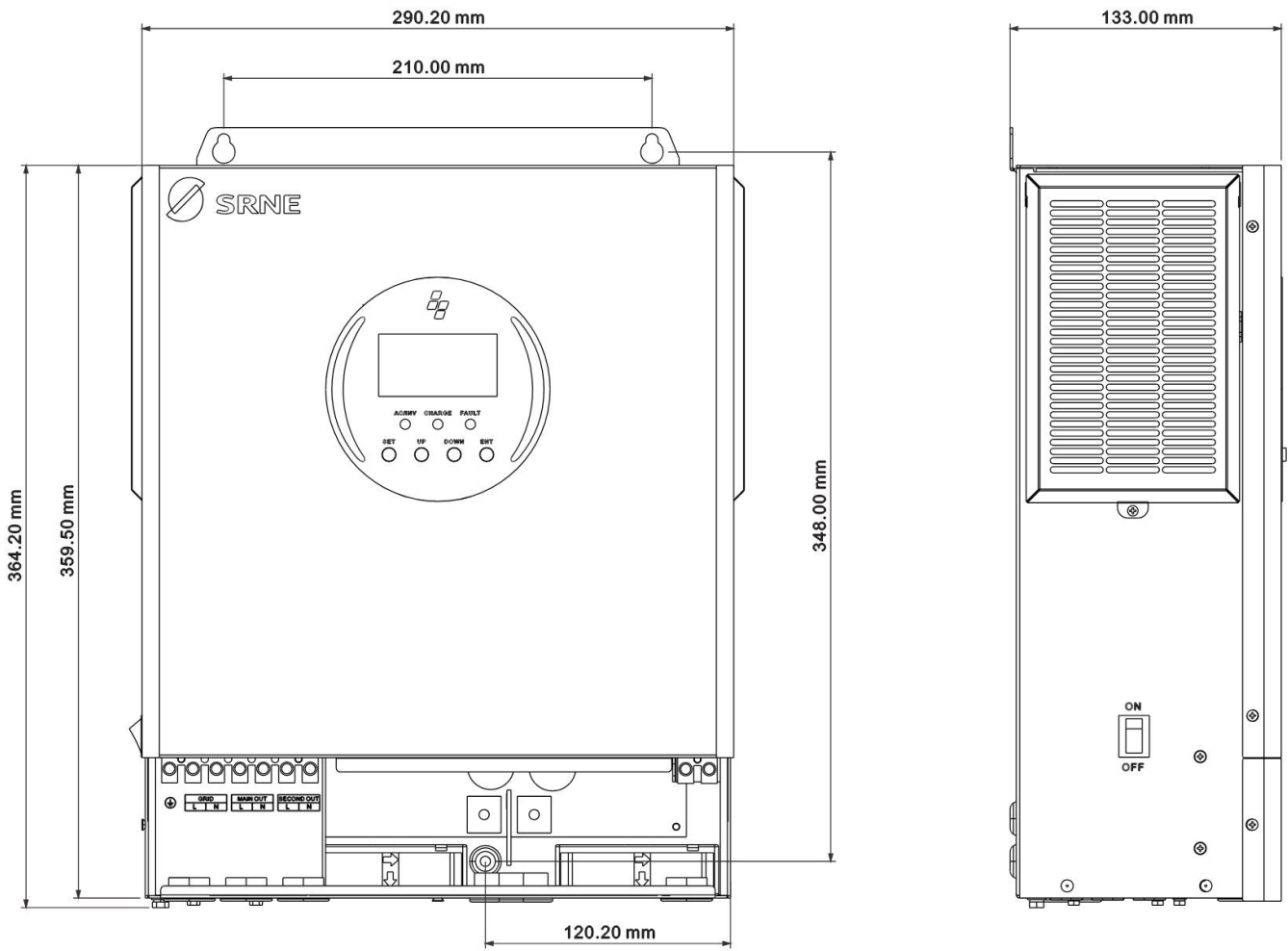









## 2. Installation instruction

### 2.1 Installation precautions

Before installation, please read this manual carefully and familiarize yourself with the installation steps.

- Take care while installing the battery. When installing the lead-acid liquid battery, it is required to wear goggles. Any body part contacting the battery acid must be washed with clear water in time.
- Don't place any metal object beside the battery to prevent short circuit of the battery.
- Acid gas may be generated during battery charge. Therefore, it is required to ensure good ventilation around the environment.
- During cabinet installation, sufficient space shall be reserved around the all-in-one machine for heat dissipation; do not install the all-in-one machine and lead-acid liquid battery in the same cabinet to avoid the corrosion of the all-in-one machine by acid gas generated during battery operation.
- Only the battery with type consistent with the all-in-one machine can be charged.
- Loose connection points and corroded wires may cause great heat, thereby melting the insulation layer of wires, burning the surrounding materials, or even causing fire. Therefore, all connectors must be tightened, and the wires must be fixed with ties, so as to avoid the looseness of connectors caused by wire shaking during mobile application.
- When installing outdoors, avoid direct sunlight and water infiltration.
- Even after the power switch is turned off, there is still high voltage inside the all-in-one machine. Do not open or touch the internal components. Perform relevant operations after the capacitor has been discharged.
- Please do not install the all-in-one machine in harsh environments such as wet, greasy, flammable, explosive areas or places with a large accumulation of dust.
- Reversing the polarity of the battery input terminal of this product is strictly prohibited. Otherwise, it may easily damage the equipment or cause unpredictable dangers.
- The grid input and AC output are high-voltage. Do not touch the wiring connections.
- Do not touch the fan when it is operating to prevent injury.
- For the input power of the load device, confirm that this all-in-one machine is the only input source. Do not use it in parallel with other AC input power sources to avoid damage.

## 2.2 Packing lists

No.	Picture	Description	Quantity
1		Inverter	1pcs
2		User Manual	1pcs
3		Certificate of Conformity	1pcs
4		Factory Inspection Report	1pcs
5		General Warranty Card	1pcs
6		Phillips screwdriver	2pcs
7		SC35-6 Terminal block	2pcs
8		M3 countersunk head screws	4pcs

## 2.3 Wiring specifications and circuit breaker selection

Wiring and installation methods must comply with national and local electrical code requirements. Recommended Wiring Specifications for Photovoltaic Arrays and Circuit Breaker Selection: Since the output current of the photovoltaic array is affected by the type of photovoltaic modules, connection method, and illumination angle, the minimum wire diameter of the photovoltaic array is calculated based on the short - circuit current of the photovoltaic array. Please refer to the short - circuit current value in the photovoltaic module specification sheet (the short - circuit current remains unchanged when photovoltaic modules are connected in series; when connected in parallel, the short - circuit current is the sum of the short - circuit currents of all parallel modules). The short - circuit current of the array must not exceed the maximum PV input current.

➤ Refer to the following table for the PV input wire diameter and switch :

Model	Recommended PV input wire diameter	Maximum PV input current	Recommended air switch or circuit breaker model
AFP4850S100-H	14mm <sup>2</sup> /2AWG	22A	2P—25A

**Note:** The voltage must not exceed the maximum PV input open circuit voltage when connected in series.

➤ Refer to the following table for recommended AC input wire sizes and switches :

Model	Recommended AC input wire diameter	Maximum bypass input current	Recommended air switch or circuit breaker model
AFP4850S100-H	10mm <sup>2</sup> /6AWG	40A	2P—40A

**Note:** A corresponding circuit breaker already exists at the grid input wiring, so a circuit breaker may not be added.

➤ Refer to the table below for recommended battery input wire sizes and switches :

Model	Recommended battery wire diameter	Max. charging current	Recommended air switch or circuit breaker model
AFP4850S100-H	3mm <sup>2</sup> /25AWG	100A	2P—1250A

➤ Refer to the following table for recommended AC output wiring specifications and circuit breakers :

Model	Recommended AC input wire diameter	Rated inverter AC output current	Max. bypass output current	Recommended air switch or circuit breaker model
AFP4850S100-H	10mm <sup>2</sup> /6AWG	21.7A	40A	2P—40A

**Note:** The wiring wire diameter is for reference only. When the distance between the photovoltaic array and the all - in - one machine or between the all - in - one machine and the battery is relatively long, using a thicker wire can reduce voltage drop and improve system performance.

**Note:** The above - mentioned wiring wire diameters and circuit breakers are only recommendations. Please select appropriate wiring wire diameters and circuit breakers according to the actual situation.

## 2.4 Installation and wiring

### Installation steps:

**Step1** : Determine the installation location and heat dissipation space. First, decide on the installation position for the all - in - one machine, such as on a wall. When installing the all - in - one machine, ensure that there is sufficient air flowing through the heat sinks of the machine. Leave at least 200 mm of space at the left and right air outlets of the all - in - one machine to guarantee natural convection for heat dissipation. Refer to the above overall machine installation schematic diagram.



**Warning:** Risk of explosion! Never install the all-in-one machine and the lead-acid liquid battery in the same enclosed space! Also, do not install them in an enclosed area where battery gases may accumulate.

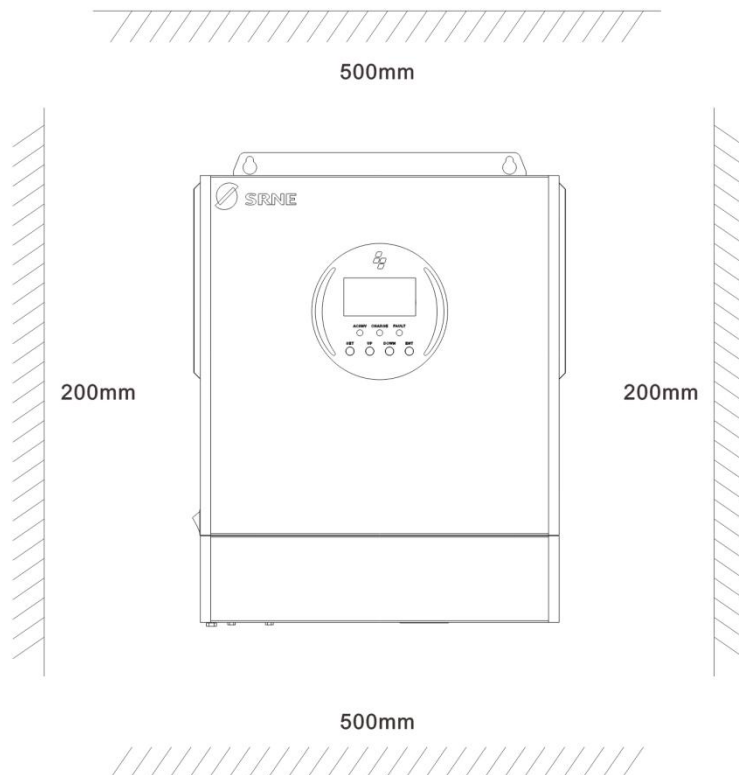

**Step 2 :** Remove the terminal protection cover.

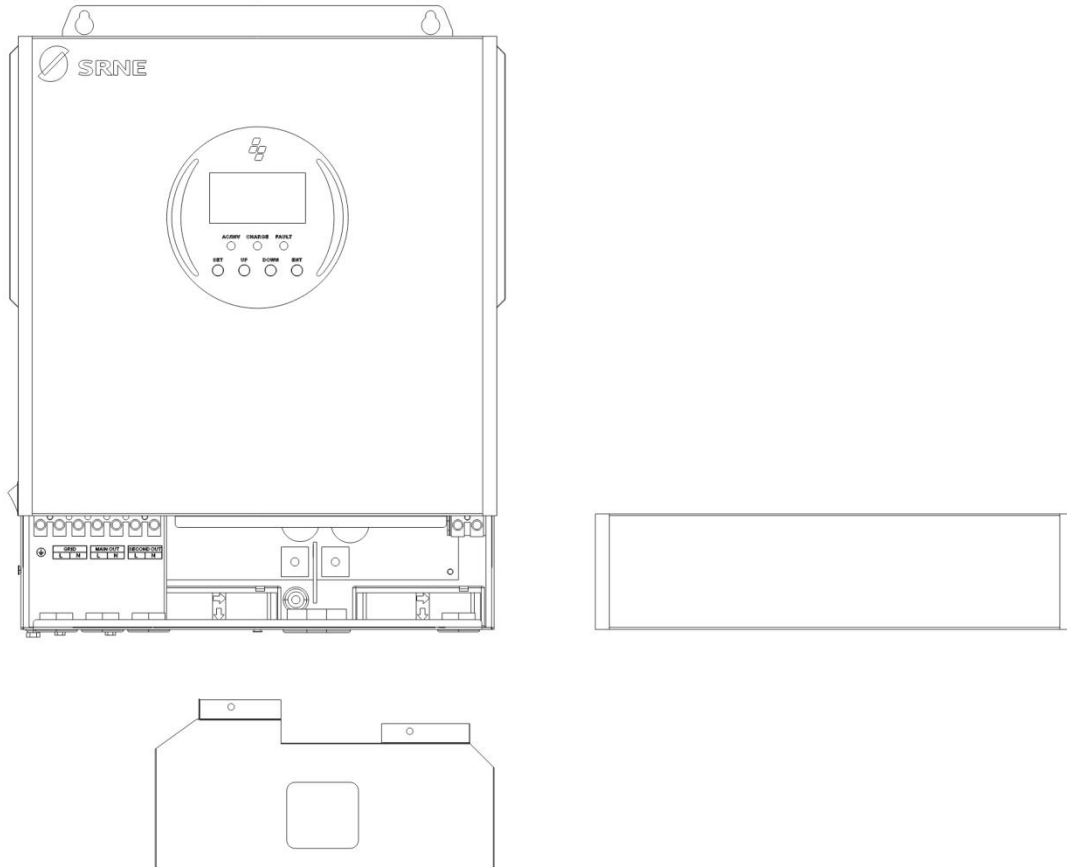

**Step 3 :** wiring

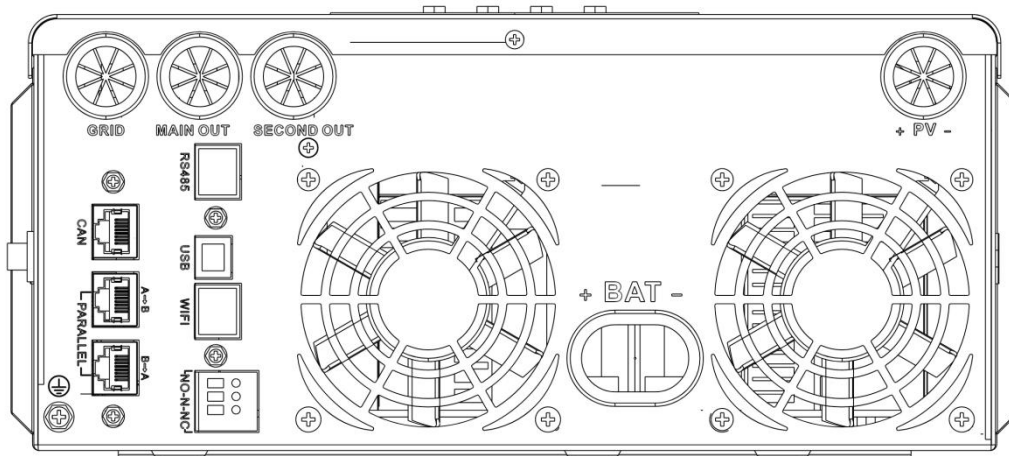

**AC input/output wiring method:**

- ① Before wiring the AC input/output, first turn off the external circuit breaker and confirm whether the cables used are thick enough. Please refer to the section "2.3 Wiring specifications and circuit Breaker Selection".
- ② Connect the AC input wires correctly according to the cable sequence and terminal positions shown in the following figure. First, connect the ground wire, and then connect the live wire and the neutral wire.

⊕: Ground wire; L: Live wire; N: Neutral wire

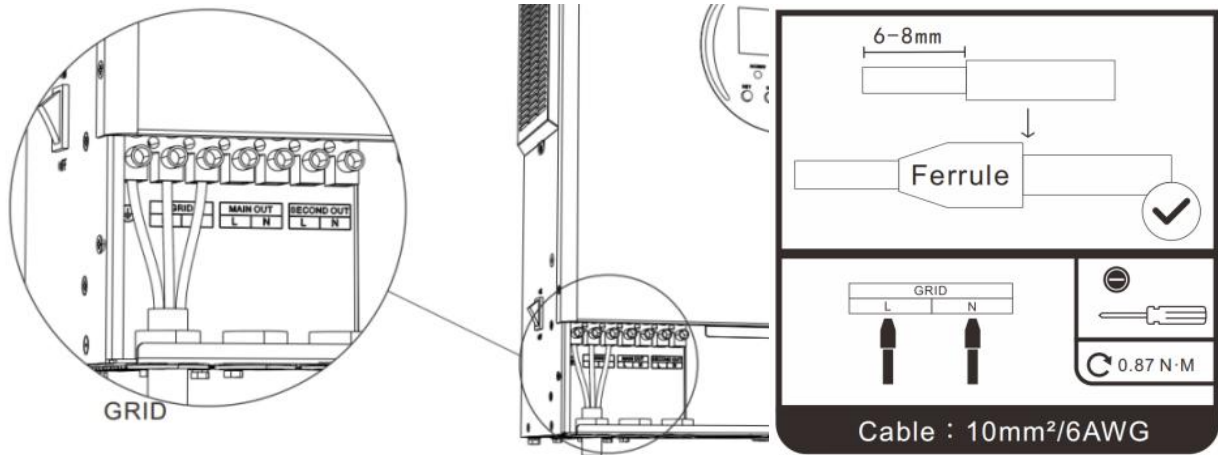

③ Connect the AC output wires correctly according to the cable sequence and terminal positions shown in the following figure. First, connect the ground wire, and then connect the live wire and the neutral wire. Connect the ground wire to the grounding screw hole of the chassis through an O-shaped terminal.

#### Main load output port :

⊕: Ground wire; L: Live wire; N: Neutral wire

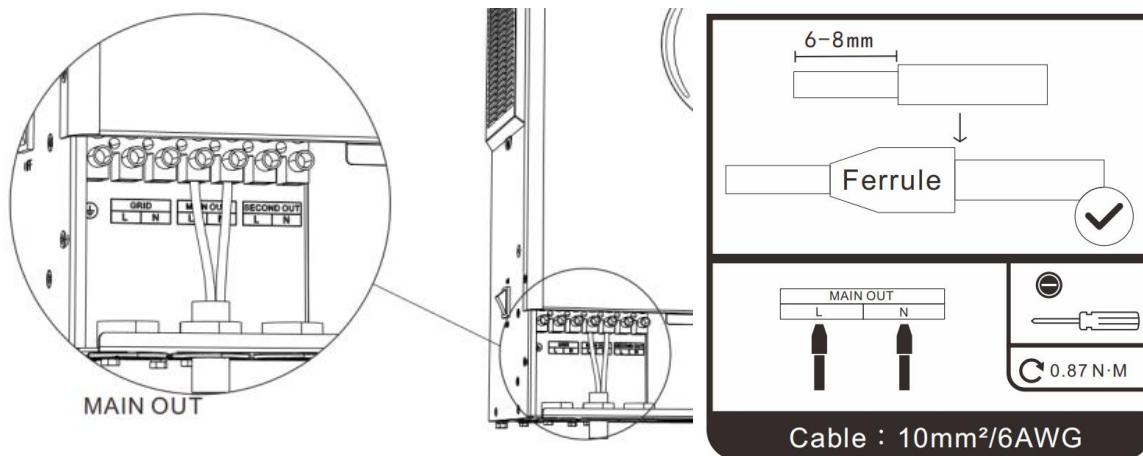

#### Secondary load output port :

Disconnection logic: When there is no mains power, adjust according to the battery level and setting items (Items 61/62 when communicating with the battery, and Items 04/05 when not communicating with the battery), and turn off or turn on the output of the second load.

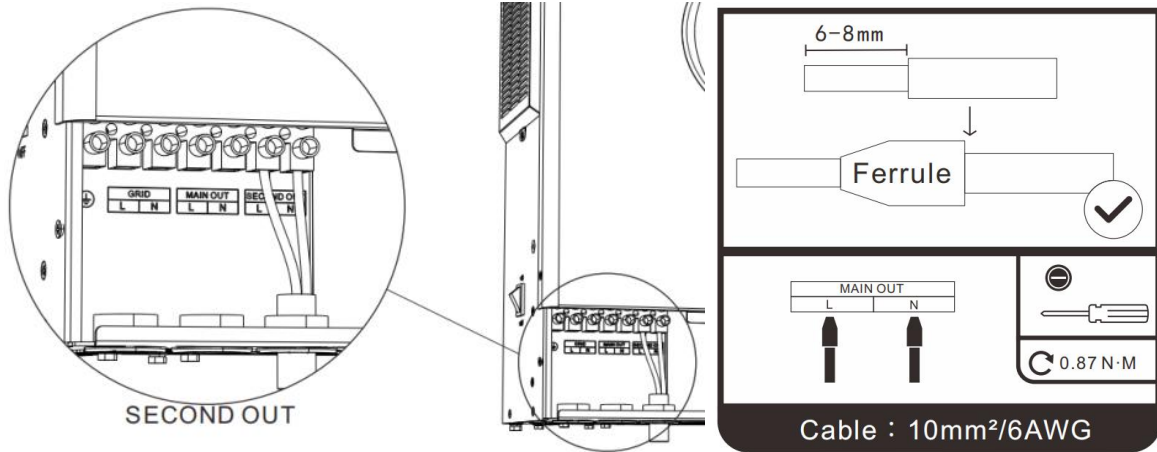

**Note:** Try to use a thick wire for the grounding cable (the cross-sectional area of the conductor should not be less than 4mm<sup>2</sup>), and the grounding point should be as close as possible to the all-in-one machine. The shorter the grounding wire, the better.

### Wiring method for PV input :

- ① Before wiring, turn off the external circuit breaker first and confirm whether the cables to be used are thick enough. Please refer to the section "2.3 Wiring specifications and circuit breaker selection". ;
- ② Connect the PV input wires correctly according to the cable sequence and terminal positions shown in the following figure.

**PV+ : positive input pole      PV1- : negative input pole**

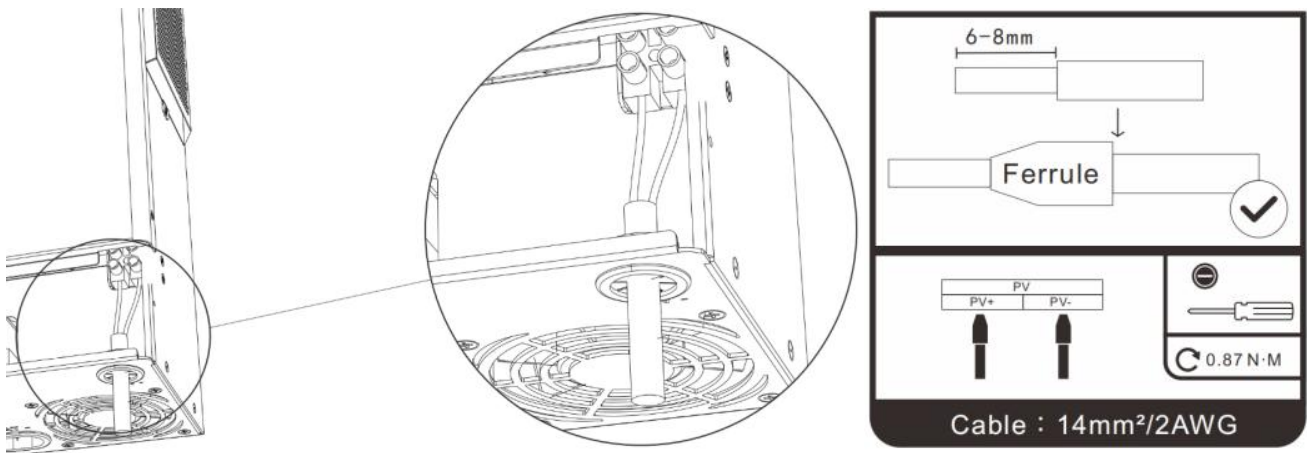

### BAT wiring method:

- ① Before wiring, first disconnect the external circuit breaker and confirm whether the cables to be used are thick enough. Please refer to the section "2.3 Wiring specifications and circuit breaker selection". The BAT wire needs to be connected to the machine through an O-shaped terminal. An O-shaped terminal with an inner diameter of 6MM is recommended. The O-shaped terminal must firmly crimp the BAT wire to prevent excessive heating caused by excessive contact impedance.
- ② Connect the BAT wires correctly according to the cable sequence and terminal positions shown in the following figure.

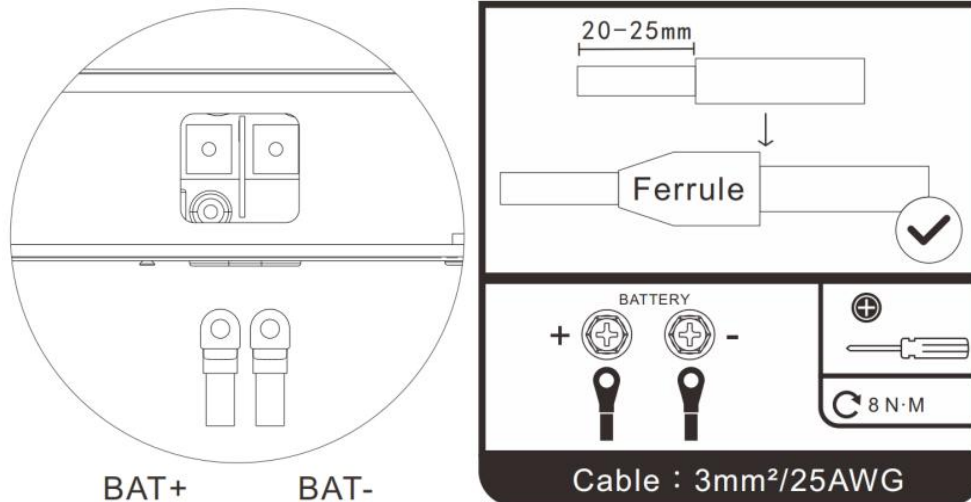
**BAT+ : positive battery pole**
**BAT- : negative battery pole**

**Warnings :**

- ① The mains input, AC output, and photovoltaic array can generate extremely high voltages. Before making any wiring connections, it is absolutely necessary to disconnect the circuit breaker or fuse.
- ② During the wiring process, safety must be given top priority. Do not close the circuit breaker or fuse during the wiring process. At the same time, ensure that the "+" and "-" pole leads of each component are connected correctly. A circuit breaker must be installed at the battery terminal, and for its selection, please refer to the section "2.3 Wiring specifications and circuit breaker selection". Before wiring, be sure to disconnect the circuit breaker to prevent strong sparks from occurring during the wiring process and to avoid battery short circuits during the wiring operation. If the all-in-one machine is used in areas with frequent lightning strikes, it is recommended to install an external lightning arrester at the PV input terminal.

**Step 4 :** Check whether the wiring is correctly connected and secure. In particular, verify whether the positive and negative terminals of the battery input are reversed, whether the positive and negative terminals of the PV input are reversed, and whether the AC input is mistakenly connected to the AC output terminal.

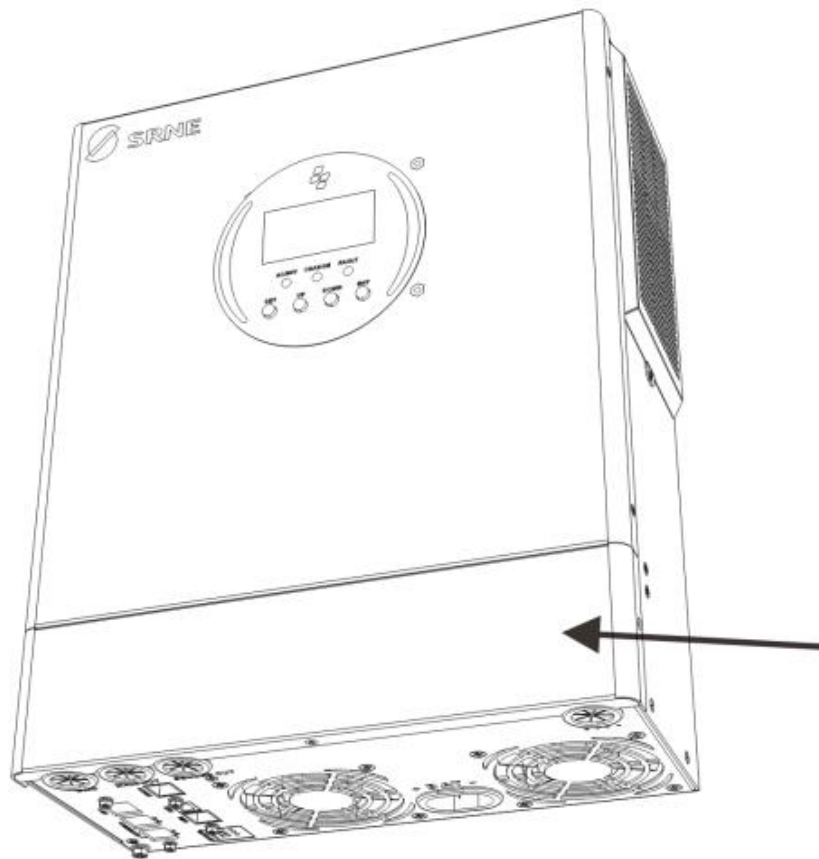
**Step 5 :** Install terminal protection cover.



**Step 6** : Start all-in-one machine.

First, close the circuit breaker at the battery terminal. Second, switch the rocker switch under the left side of the machine to the "ON" position. When the "AC/INV" indicator light flashes, it indicates that the inverter is working properly. Third, close the circuit breakers of the photovoltaic array and the mains power. Finally, after the AC output is normal, turn on the AC loads one by one. This is to prevent the protection mechanism from being triggered due to a large instantaneous surge when all loads are turned on simultaneously. Then the all - in - one machine will operate normally according to the set mode.

**Note** : If power is supplied to different AC loads, it is recommended to turn on the load with high inrush current first, and then turn on the load with low inrush current after the load has stabilized its work.

**Note** : If the All-in-One does not work normally and the LCD or indicator light shows abnormality, refer to section "6.3 Partial troubleshooting measures".

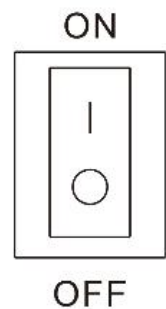

## 2.5 Parallel machine wire connection

### 2.5.1 Introduction

1. Up to six units connected in parallel.
2. When using the parallel operation function, the following connecting lines (package accessories) shall be firmly and reliably connected:

#### Parallel communication cable\*1

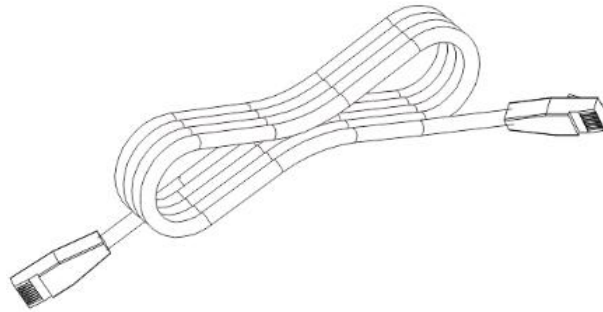

### 2.5.2 Precautions for connecting the parallel connecting lines

Warning:



#### 1. Battery wiring:

**Parallel connection in single or three phase:** Ensure that all all-in-one solar charger inverters are connected to the same battery, with BAT + connected to BAT + , BAT - connected to BAT - , and that the connection is correct with the same wiring length and line diameter before power on and start-up, so as to avoid the abnormal operation of parallel system output caused by wrong connection.

#### 2. AC OUT wiring:

**Parallel connection in single phase:** Ensure L-to-L, N-to-N and PE-to-PE connection for all all-in-one solar charger inverters, and that the connection is correct with the same wiring length and line

diameter before power on and start-up, so as to avoid the abnormal operation of parallel system output caused by wrong connection. For specific wiring, please refer to 2.4.3 Wiring Diagram

**Parallel connection in three phase:** Ensure N-to-N and PE-to-PE connection for all all-in-one solar charger inverters. The **L** lines of all inverters connected to the same phase need to be connected together. But **L** lines of different phases cannot be joined together. Other connection precautions are the same as parallel connection in single phase. For specific wiring, please refer to 2.4.4 Wiring Diagram

### 3. **AC IN wiring:**

**Parallel connection in single phase:** Ensure L-to-L, N-to-N and PE-to-PE connection for all all-in-one solar charger inverters, and that the connection is correct with the same wiring length and line diameter before power on and start-up, so as to avoid the abnormal operation of parallel system output caused by wrong connection. Meanwhile, it is not allowed to have multiple different AC source inputs to avoid damage to the external equipment of the inverter. The consistency and uniqueness of AC source input shall be ensured. For specific wiring, please refer to 2.4.3 Wiring Diagram.

**Parallel connection in three phase:** Ensure N-to-N and PE-to-PE connection for all all-in-one solar charger inverters. The **L** lines of all inverters connected to the same phase need to be connected together. But **L** lines of different phases cannot be joined together. Other connection precautions are the same as parallel connection in single phase. For specific wiring, please refer to 2.4.4 Wiring Diagram.

### 4. **Wiring of parallel communication line:**

**Parallel connection in single or three phase:** Our company's parallel communication line is a DB15 standard computer cable with shielding function. Ensure the "one-in-one-out" rule when connecting each inverter, that is, connect the male connector (out) of this inverter with the female connector (in) of the inverter to be paralleled. Do not connect the male connector of the inverter to its female connector. In addition, make sure to tighten the parallel communication line of each inverter with self-contained end screws of DB15 to avoid the abnormal operation or damage of the system output caused by the falling off or poor contact of the parallel communication line.

### 5. **Wiring of current sharing detection line:**

**Parallel connection in single phase:** Our company's current sharing detection line is a twisted connection line. Ensure the "one-in-one-out" rule when connecting each inverter, that is, connect the current sharing line of the inverter with the current sharing green port of the inverter to be

paralleled (choose one port from the two, and there is no mandatory sequence requirement). The current sharing ports of the inverter cannot be connected to each other. In addition, make sure that the red and black current sharing connection lines of each inverter are not manually exchanged, and make sure to tighten the lines with self-contained screws to avoid the abnormal operation or damage of the system output caused by abnormal parallel current sharing detection. For specific wiring, please refer to 2.4.3 Wiring Diagram.

**Parallel connection in three phase:** The current sharing detection lines of all inverters connected to the same phase need to be connected together. But the current sharing detection lines of different phases cannot be joined together. Other connection precautions are the same as parallel connection in single phase. For specific wiring, please refer to 2.4.4 Wiring Diagram.

6. Before or after connecting the system, please carefully refer to the following system wiring diagram to ensure that all wiring is correct and reliable before power on.
  
7. After the system is wired, powered on and in normal operation, if a new inverter needs to be connected, make sure to disconnect the battery input, PV input, AC input and AC output, and that all all-in-one solar charger inverters are powered off before reconnecting into the system.

### 2.5.3 Schematic diagram of parallel connection in single phase

1. In the case of multiple parallel machines, the parallel connection guide diagram is as follows.
  - a) **Two all-in-one solar charger inverters of the system connected in parallel:**

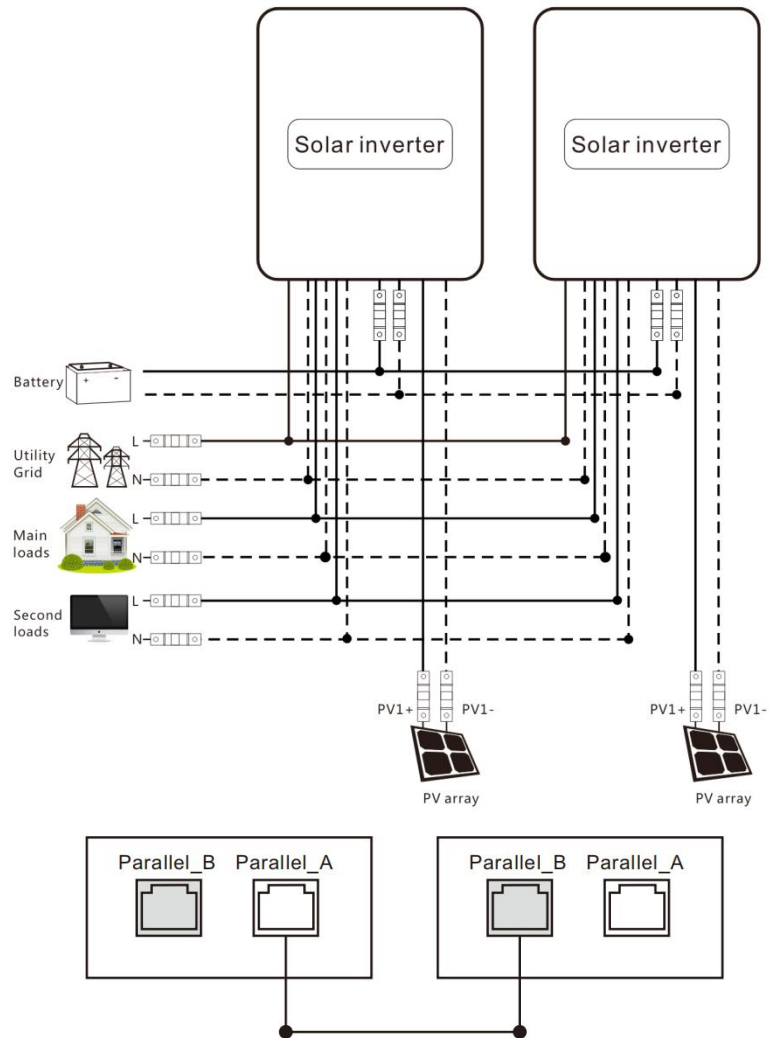

- b) **Three all-in-one solar charger inverters of the system connected in parallel:**

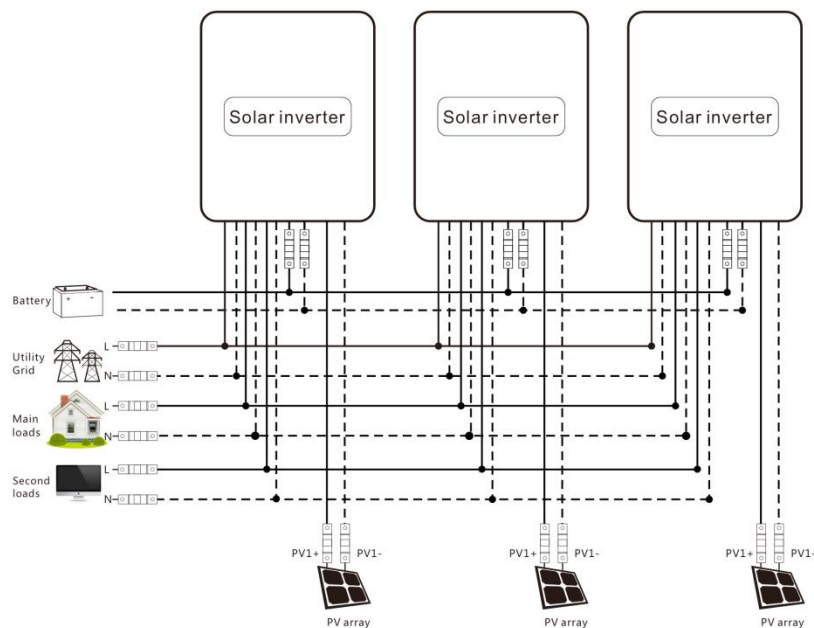

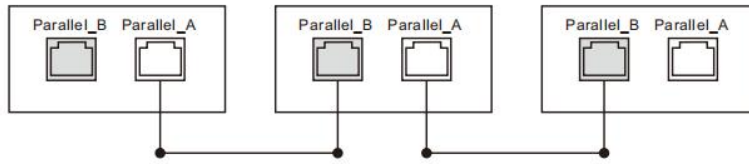

**c) Four all-in-one solar charger inverters of the system connected in parallel:**

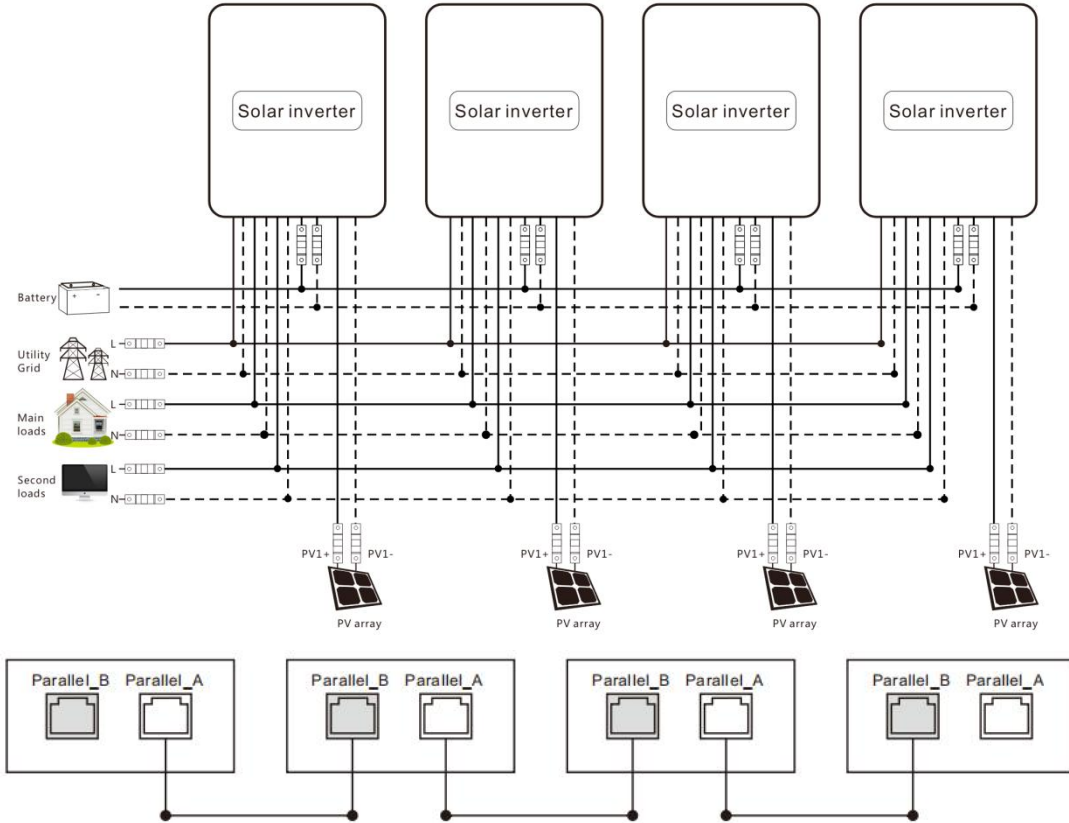

**d) Five all-in-one solar charger inverters of the system connected in parallel:**

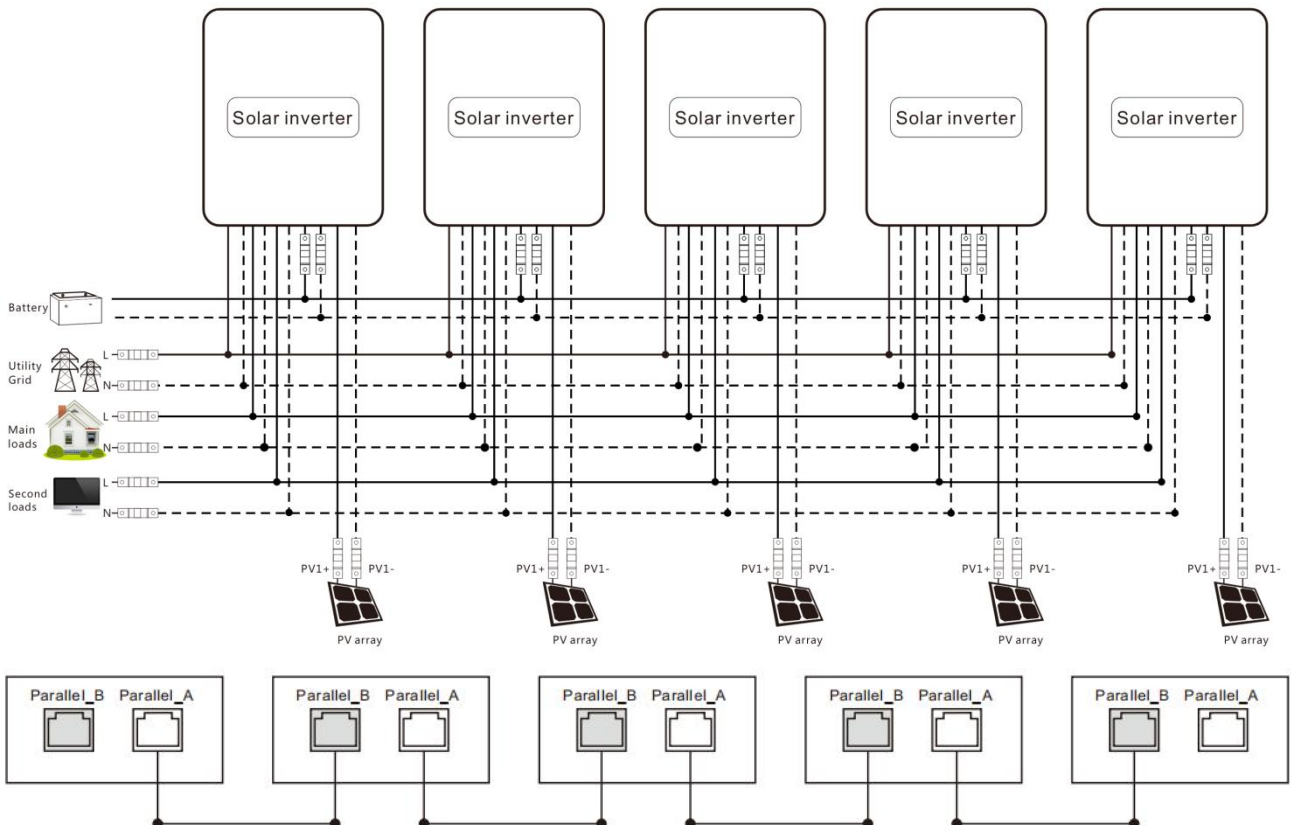

e) Six all-in-one solar charger inverters of the system connected in parallel:

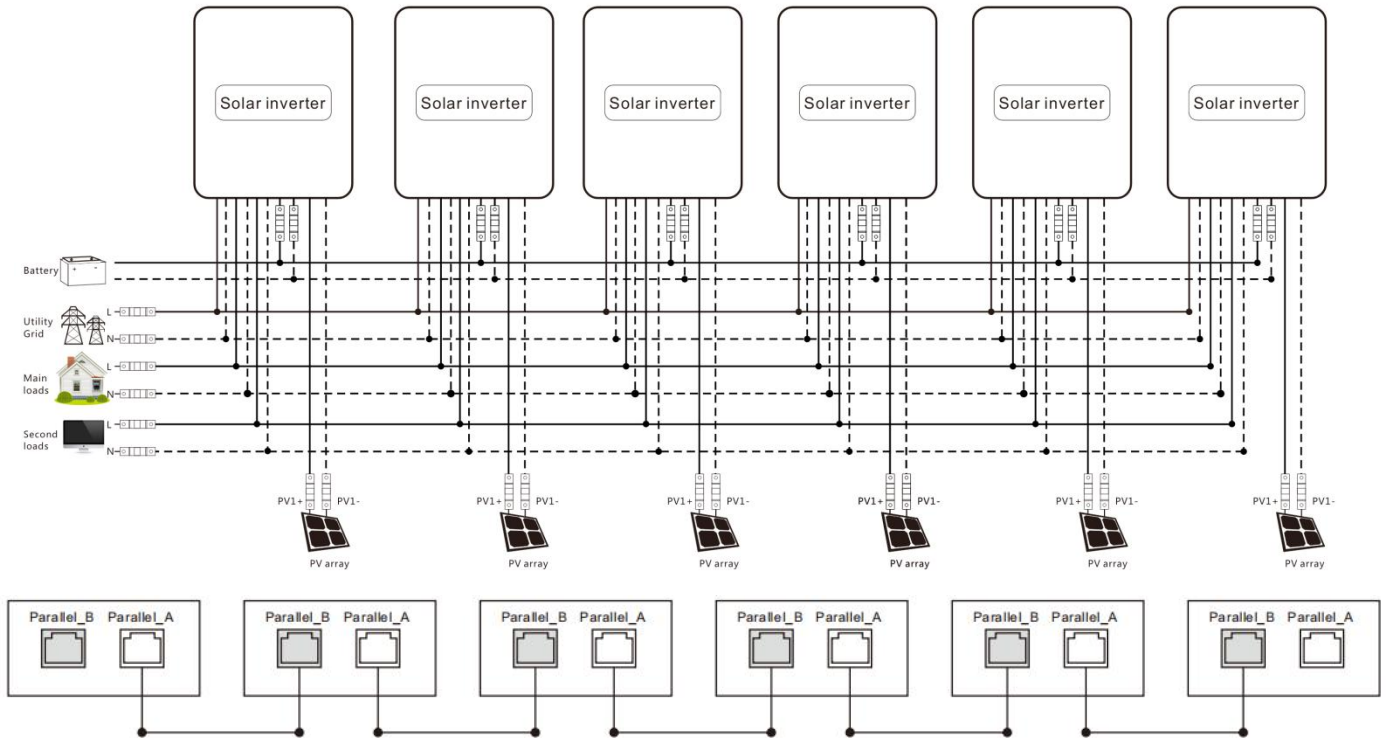

### 2.5.4 Schematic diagram of parallel connection in three phase

In case of parallel operation with multiple inverters, the schematic diagram of parallel connection is as follows:

#### Parallel Operation in three phase :

a) Three all-in-one solar charger inverters of the system connected in three phase:

**1+1+1 system:**

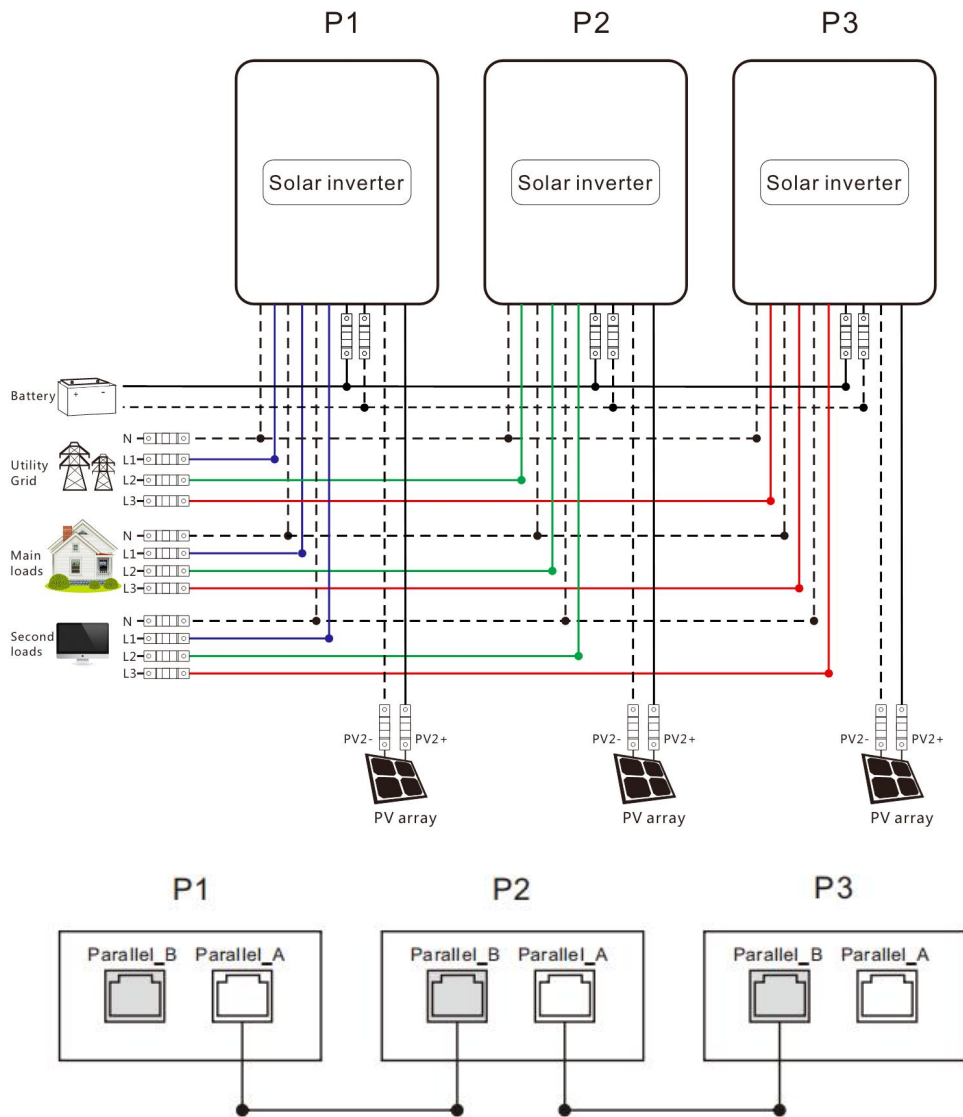

**b) Four all-in-one solar charger inverters of the system connected in three phase:**

**2+1+1 system:**

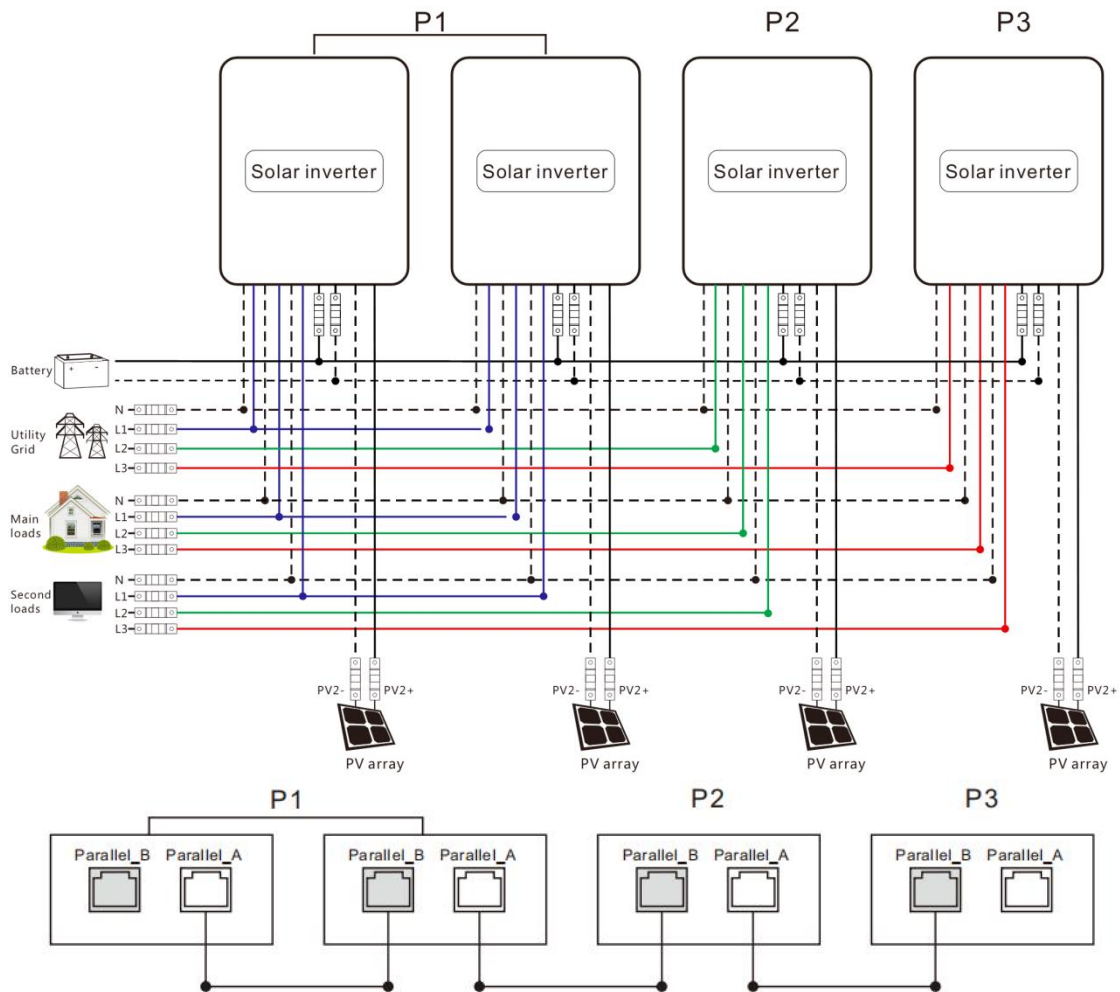

**c) Five all-in-one solar charger inverters of the system connected in three phase:**

**3+1+1 system:**

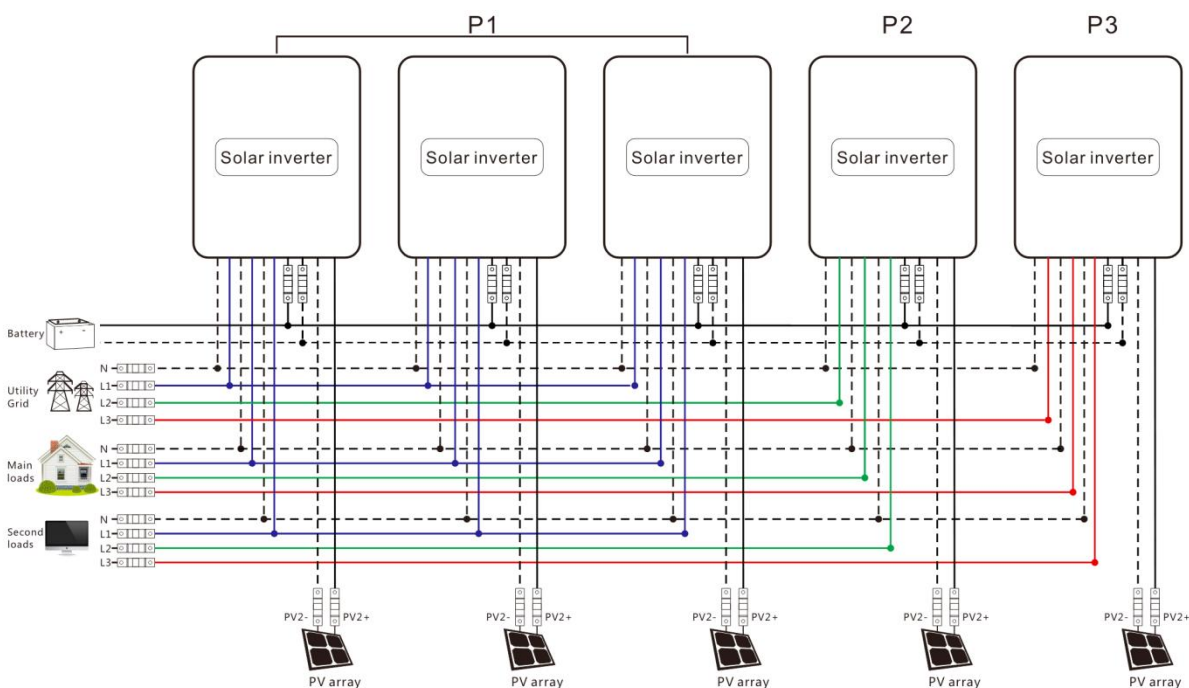

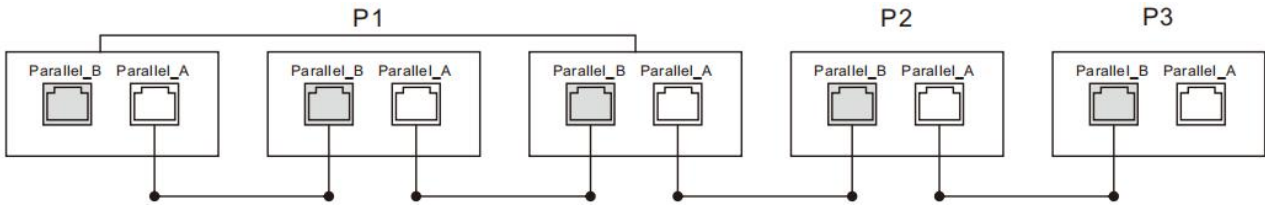

**2+2+1 system:**

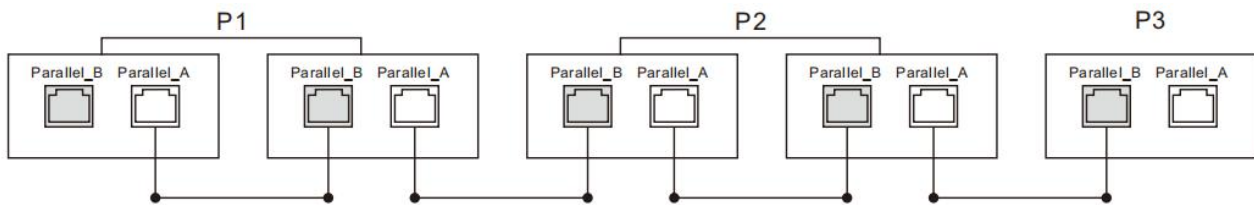
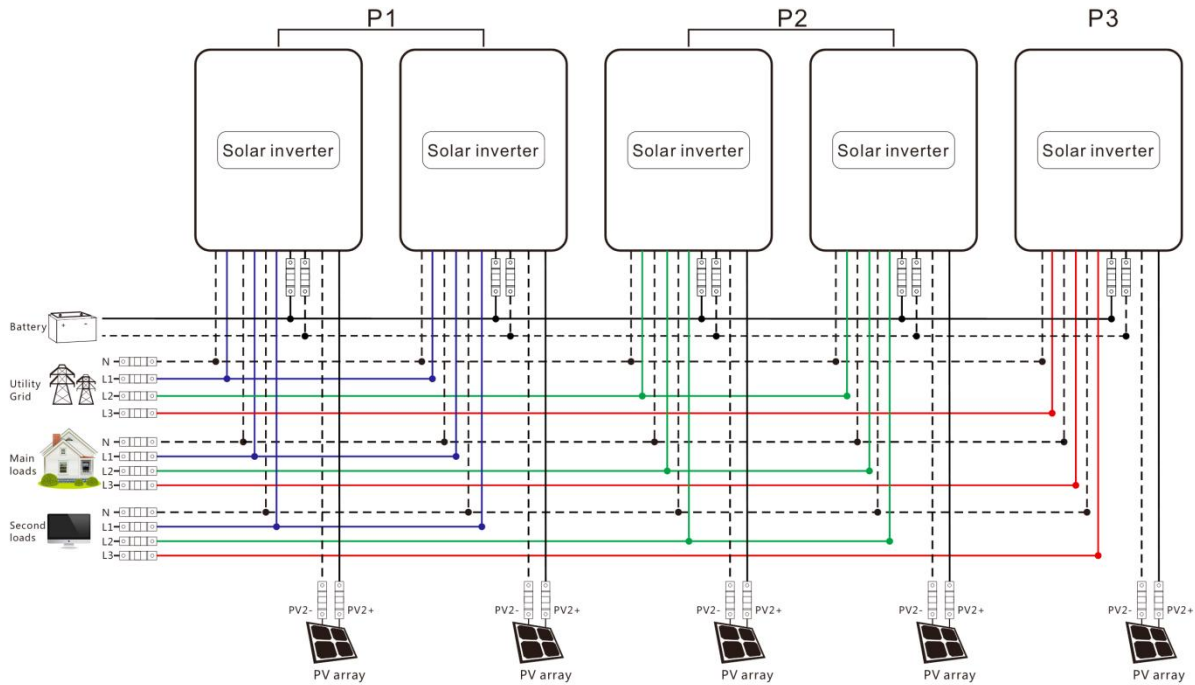

**d) Six all-in-one solar charger inverters of the system connected in three phase:**

**2+2+2 system:**

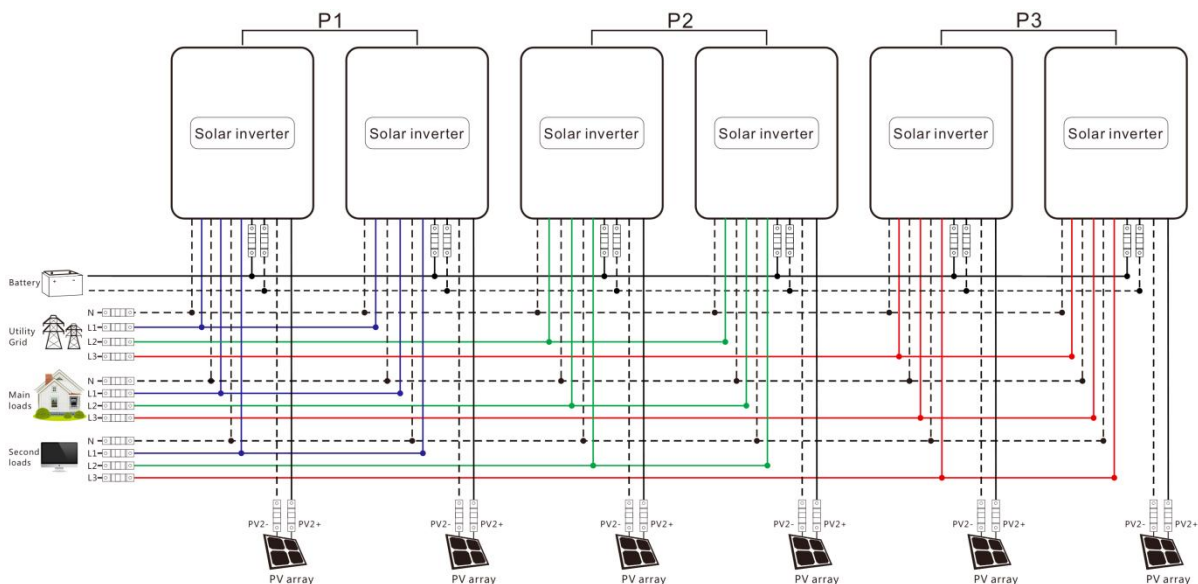

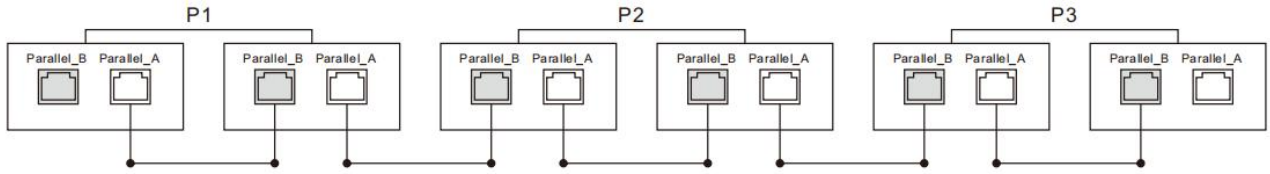

**3+2+1 system:**

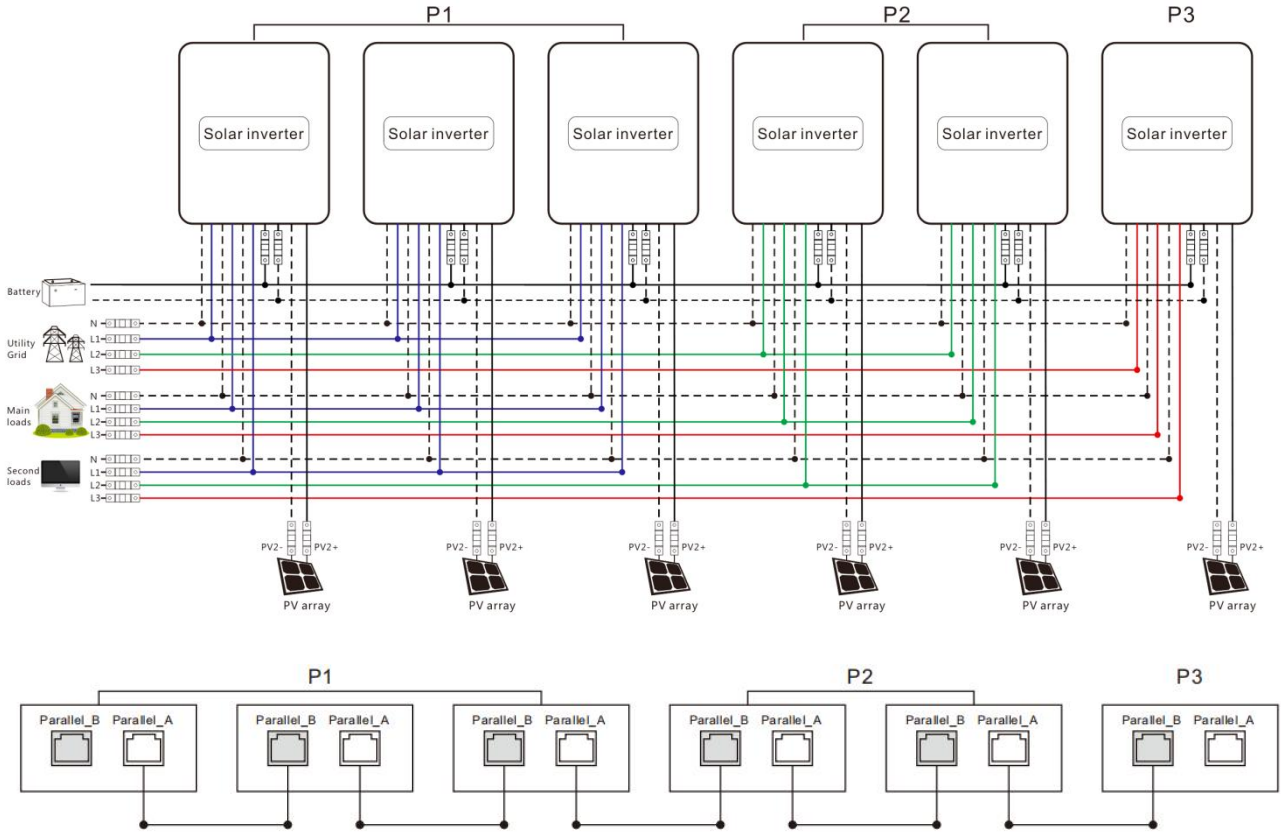

**4+1+1 system:**

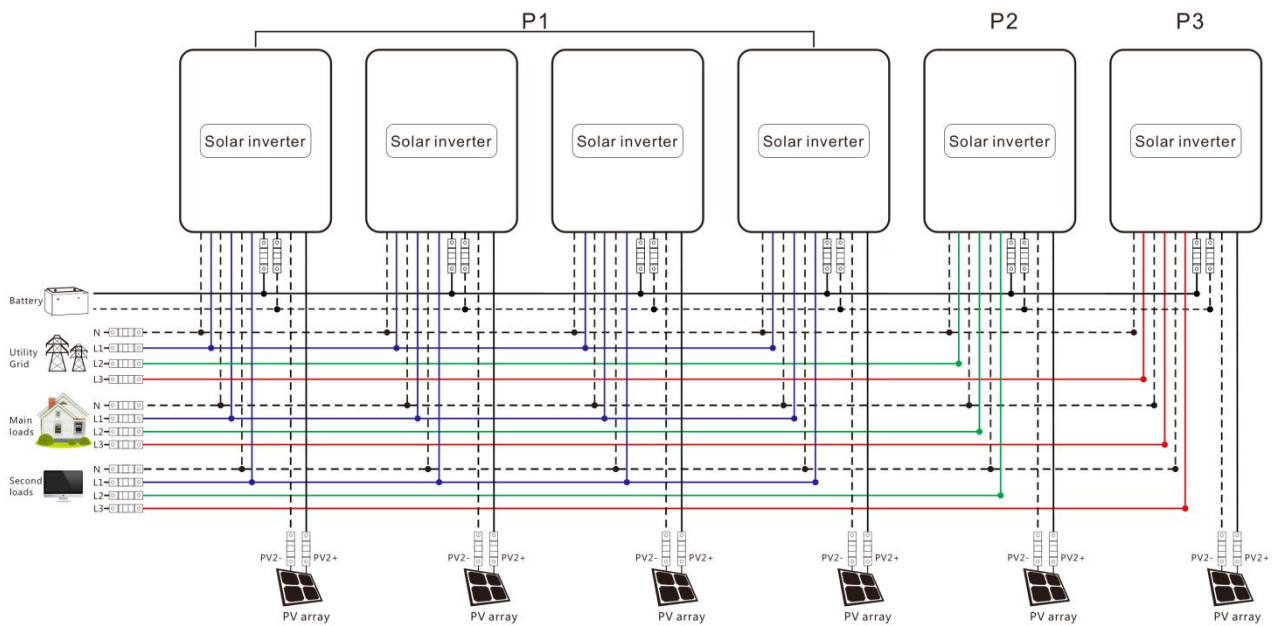

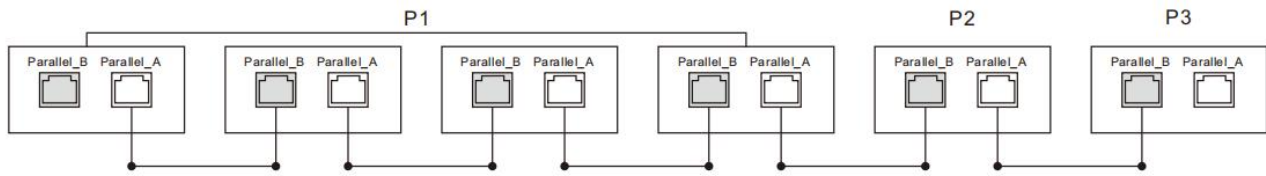

**Note:**

- 1) Before starting up and running, please check whether the connection was correct to avoid any abnormalities in the system.
- 2) All wiring must be fixed and reliable to avoid wire drop during use.
- 3) When the AC output is wired to the load, it shall be properly wired according to the requirements of the electrical load equipment to avoid damage to the load equipment.
- 4) Settings [38] need to be set consistently or only for the host. When the machine is running, the voltage set by the host shall prevail, and the master will force the rewrite of the other slave machines to keep the same set. Only can be set in the standby mode.
- 5) Machine factory default for single machine mode, if you use parallel, split-phase or three-phase function, you need to set the [31] item parameters through the screen. The setting method is: power on one machine at a time, the rest of the machine off, and then set the [31] item parameters according to the site system operation mode. After this machine is set successfully, turn off the machine switch and wait for the machine to be powered down, then set the rest of the machines in turn until all machines are set, and then all machines are powered up again at the same time and enter the working state.

The [31] setting item :

When using the single-phase parallel function, the [31] item is set to "PAL". When using the three-phase parallel function, the [31] setting item needs to be set as follows.

All connected P1-phase inverters are set to "**3P1**" ;

All connected P2-phase inverters are set to "**3P2**" ;

All connected P3-phase inverters are set to "**3P3**" ;

At this time, the voltage phase difference between P1-P2, P1-P3, and P2-P3 is 120 degrees, and when the output voltage set in [38] setting item is 230Vac, the voltage between the fire line L1 of phase P1 and the fire line L2 of phase P2 is  $230 \times 1.732 = 398\text{Vac}$ , and similarly the line voltage between L1-L3, L2-L3 is 398Vac; the voltage between L1-N, L2-N, L1-N, L2-N, and L3-N, the voltage between the lines is 230Vac.

- 6) After the system runs, the output voltage is measured correctly, and then the load setting is connected.

### 3. Operating mode

#### 3.1 Charge mode

① **Hybrid charging** : PV and grid hybrid charging, prioritize PV MPPT charging, when PV energy is insufficient, grid replenish. When the PV energy is sufficient, the grid stops charging. This way of charging is the fastest, suitable for areas with unstable power grid, and can provide sufficient backup power supply at any time.

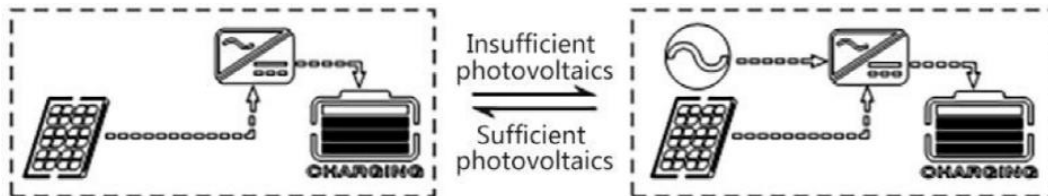

② **Only Solar** : Only PV charge is used, no mains supply is started. This way can save the energy at most. The electric energies of battery are all from solar energy. This way is suitable for areas with good light condition.

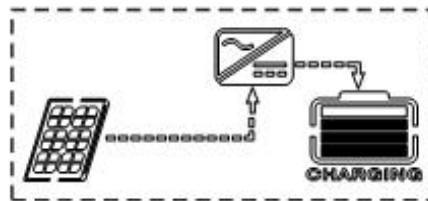

#### 3.2 Power supply mode

① **PV priority mode**: Switches to grid power and charging when photovoltaics are not effective. This mode maximizes the use of solar energy while maintaining battery power, and is suitable for areas with relatively stable power grids. The realized power supply sequence is prioritized as follows: PV - grid - battery.

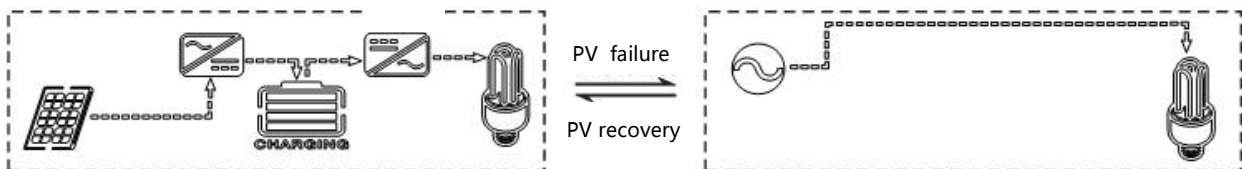

② **Grid power priority mode** : Switch to battery inverter power supply only when there is no grid power, and switch to grid charging and power supply use when there is grid power. The equipment is equivalent to a backup UPS, used in areas with unstable power grids. Switching does not affect the photovoltaic charging.

The realized power supply order priority is: Grid - PV - battery.

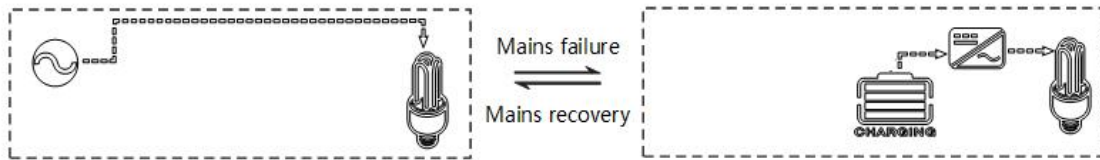

③ **Inverter priority mode:** Switches to mains power only when the battery voltage is below the set point (04 set item), and switches to battery discharge mode when the grid charging battery voltage is above the (05 set item) set point, cycling the battery charging and discharging. This mode maximizes the use of DC power and is used in areas with stable power grids. Switching does not affect PV charging. (PV-Battery-grid power supply sequence prioritization).

The realized power supply sequence is prioritized as follows: PV - Battery - Grid.

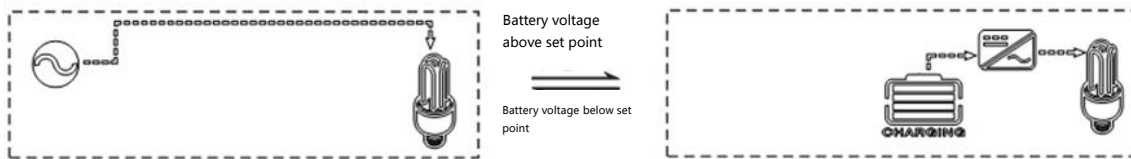

④ **Hybrid Load-Bearing and Grid Connection Settings:** Mixed carry mode, under grid mode, PV only prioritizes charging, the remaining energy is supplied to the load and not fed into the grid; grid-connected function, under utility mode, PV prioritizes charging, the remaining energy is supplied to the load and fed into the grid.

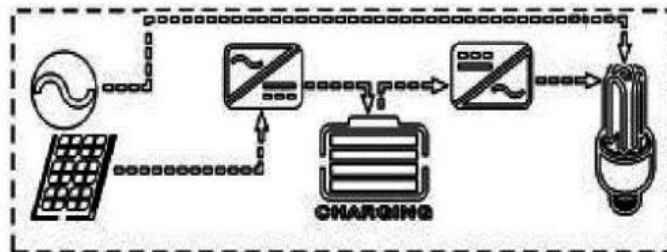

## 4. Operation instruction for LCD screen

### 4.1 Operation and display panel

The operation and display panel is shown in the following figure, which includes 1 LCD screen, 3 indicator lights, and 4 operation buttons.

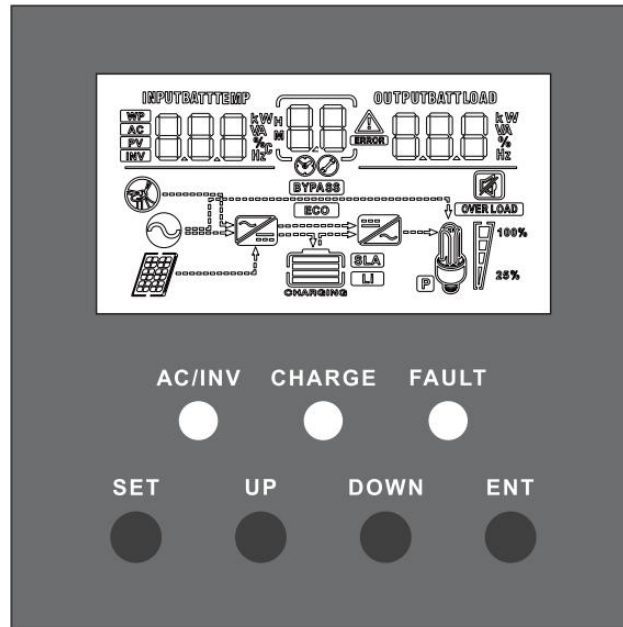









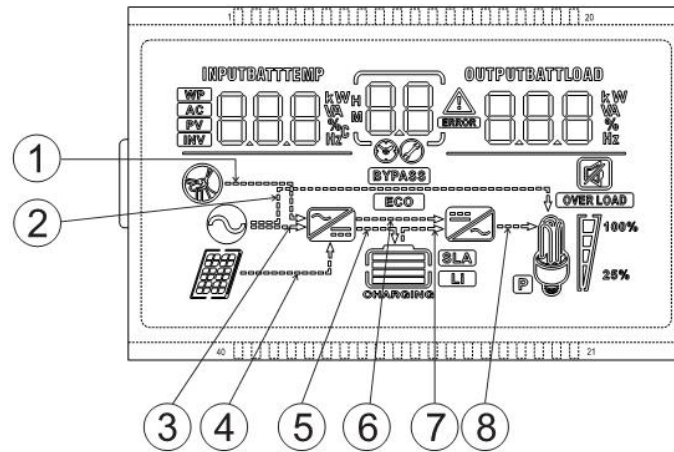











#### Introduction to the operation buttons





Function button	Description
SET	Enter/exit setting menu
UP	Last option
DOWN	Next option
ENT	Confirm/enter option under setting menu

#### Introduction to the indicator lights

Indicator light	Color	Description
AC/INV	Yellow	Constantly on: Mains power output
		Flashing: Inverter output
CHARGE	Green	Flashing: fast charging
		Constantly on: Float Charge
FAULT	Red	Flashing: Fault status



Icon	Function	Icon	Function
	Indicates that the AC input is connected to an AC input source.		Indicates that the inverter discharge circuit is operating.
	This icon indicates a wide voltage AC input mode (APL mode).	<b>BYPASS</b>	Indicates that the machine is in the mains bypass (Bypass) operating mode.
	Indicates that the PV input is connected to the solar panel.	<b>OVER LOAD</b>	Indicates that the AC output is in an overload condition.
	Indicating that machine has been connected to battery,  indicating 0%~24% battery remaining capacity,  indicating 25%~49% battery remaining capacity,  indicating 50%~74% battery remaining capacity,  indicating 75%~100% battery remaining capacity.		Indicating percentage of AC output load,  indicating 0%~24% load percentage,  indicating 25%~49% load percentage,  indicating 50%~74% load percentage,  indicating ≥75% load percentage.
<b>LI</b>	Indicating that present battery type of the machine is lithium battery.		Indicates that the buzzer is not enabled.
<b>SLA</b>	Indicating that current battery type of machine is lead-acid battery.		Indicates that a machine alarm has occurred.
<b>CHARGING</b>	Indicating that the battery is in charge state.	<b>ERROR</b>	Indicates that the machine is in a fault condition.
	Indicating that AC/PV charge circuit is in working.		Indicates that the machine is in setup mode.
	Indicating that AC output end has AC voltage output.		Parameter display in the middle of the screen. ①In non-setting mode, alarm or fault code is displayed. ②In setting mode, the currently set parameter item code is displayed.
<b>P</b>	When used in parallel, this icon display indicates that this unit is the main unit and is only valid in parallel mode.		
Parameter display at left side of screen: input parameter.			
<b>AC</b>	Indicating AC input.		

	Indicating PV input.		
	Indicating inverter circuit.		
	The icon is not displayed.		
	Display battery voltage, total battery charging current, utility charging power, AC input voltage, AC input frequency, PV input voltage, internal heat sink Temperature, software version.		
Parameter display on the right side of the screen: output parameters.			
	Indicates output voltage, output current, output active power, output apparent power, battery discharge current, and software version; in setup mode, displays the setup parameters under the currently setup parameter item code.		
<b>Arrow display</b>			
①	The arrow is not displayed.	⑤	Indicating charge from charge circuit to battery end.
②	Indicating power grid power supply to load.	⑥	The arrow is not displayed.
③	Indicating power grid power supply to charge circuit.	⑦	Indicating power supply from battery end to inverter circuit.
④	Indicating PV power supply to charge circuit.	⑧	Indicating power supply from inverter circuit to load.

### Real-time data view method

In LCD main screen, press keys "UP" and "DOWN" to turn page and view different real time data of the machine.

Page	Left Parameter of Screen	Middle Parameter of Screen	Right Parameter of Screen
1	INPUT BATT V (Battery input voltage)	Fault code	OUTPUT LOAD V (AC output voltage)
2	BMS BATT V (BMS battery voltage, valid when BMS is enabled)		BMS BATT SOC (BMS battery remaining capacity percentage, valid when BMS is enabled)
3	PV TEMP °C (Solar charging heat sink temperature)		PV OUTPUT KW (Solar charge output power)
4	PV INPUT V (Solar power input voltage)		PV OUTPUT A (Solar charge output current)
5	INPUT BATT A (Input battery current)		OUTPUT BATT A (Battery output current)
6	INPUT BATT KW (Input battery power)		OUTPUT BATT KW (Battery output power)
7	AC INPUT Hz (AC input frequency)		AC OUTPUT LOAD Hz (AC output frequency)
8	AC INPUT V (AC input voltage)		AC OUTPUT LOAD A (AC output load current)
9	Inverter Maintenance Parameters Display		OUTPUT LOAD KVA (Apparent power of the load)

10	INV TEMP °C (AC charging or battery discharging heat sink temperature)		INV OUTPUT LOAD KW (Load active power)
11	APP Software Version		Bootloader software version
12	Battery Voltage Rating		Output Power Rating
13	Model PV Voltage Rating		Model PV Charge Current Rating Model
14	RS485 Address		Phase Sequence Display

## 4.2 Setting parameter

Buttons operation instructions:

To enter or exit the settings menu, press the "SET" key. After entering the settings menu, the parameter number [00] will flash. At this time, you can press the "UP" and "DOWN" keys to select the code of the parameter item you need to set.

Then press the "ENT" key to enter the parameter editing state. At this point, the value of the parameter will flash. Use the "UP" and "DOWN" buttons to adjust the parameter value. Finally, press the "ENT" key to complete the parameter editing and return to the parameter selection state.

The voltage setting logic: 【15】 < 【12】 < 【04】 < 【14】 < 【35】 < 【37】 < 【05】 < 【09/11】 .

Parameter Number	Parameter Name	Setting Options	Description
00	Exit	[00] ESC	Exit from setting menu.
01	Work priority mode	[01] SOL	PV priority mode, switching to grid when there is no PV input or when the battery is below the value set in parameter [04].
		[01] UTI	PV priority load, when PV is not enough, grid and PV mixed load, when PV energy is enough for load, excess energy to charge the battery, grid only start charging when the battery is over-discharged (06 settings only when PV charging, grid will not charge), battery only discharged when off-grid.
		[01] SBU	Inverter priority mode, switching to mains only when the battery is undervoltage or below the value set in parameter [04]; switching to battery discharge only when the battery is fully charged or above the value set in parameter [05].
		[01] SUB default	Solar priority charging, when solar energy is insufficient, grid energy and solar energy are mixed (if 06 is set to "OSO (PV only)" , grid energy will not be charged), grid with load, when solar energy is sufficient for charging, excess energy is insufficient for the load, excess solar energy and the grid will be mixed with the load, the battery will be discharged only when it is off the grid.

02	Output Frequency	[02] 50.0 default	Bypass adaptive, when there is grid power, it automatically adapts to the frequency when the power is first listed; when there is no grid power, you can set the output frequency through this menu. 230V machine default 50HZ.
		[02] 60.0	
03	AC input voltage range	[03] APL	230V machine wide range input grid voltage range: 90~280V.
		[03] UPS default	230V machine narrow range input grid voltage range: 170~280V.
04	Battery to grid	[04]46V default	When parameter [01] = SBU, the battery voltage is lower than this setting value, the output is switched from inverter to grid, setting range 40V~57.2V. When there is no grid, the second load will be disconnected according to the second setting item for low voltage.
05	Grid to battery	[05] 56V default	When parameter [01] = SBU, the battery voltage is higher than this setting value, the output is switched from grid to inverter, setting range 53.2V~60V. When there is no grid and the voltage is higher than the value set in this item, the second load will be turned on.
06	Charging mode	[06] SNU default	Hybrid charging with PV and grid, prioritizing PV charging and supplementing with grid charging when PV energy is insufficient.
		[06] OSO	PV charging only, no grid charging activated.
07	Max. charging current	[07] 100A default	S series models, setting range 0~100A;
08	Battery type	[08] USE	User-defined, all battery parameters can be set.
		[08] SLd	Sealed lead-acid battery, constant voltage charging voltage 57.6V, float charging voltage 55.2V.
		[08] FLd	Open lead-acid battery, constant voltage charging voltage 58.4V, float charging voltage 55.2V.
		[08] GEL default	Gel lead-acid battery, constant voltage charging voltage 56.8V, float charging voltage 55.2V.
		[08] Nbt	No battery mode.
		[08] L14/L15/L16	Lithium iron phosphate battery L16/L15/L14, corresponding to lithium iron phosphate battery 16 series, 15 series and 14 series, 16 series default constant voltage charging voltage of 56.8V, 15 series default constant voltage charging voltage of 53.2V, 14 series default constant voltage charging voltage of 49.2V, can be adjusted.
		[08] N13/N14	Li-ion ternary battery, adjustable. N13 default constant voltage charging voltage 53.2V, N14 series default constant voltage charging voltage 57.6V.
09	Boost charging voltage	[09] 56.8V default	Boost the charging voltage setting, setting range 48V~58.4V, step 0.4V, valid when the battery type is customized and lithium battery.
10	Boost charge max. time	[10] 120 default	Boost charging maximum time setting, refers to the constant voltage charging when the voltage reaches the parameter [09] set voltage maximum charging time, set Fan 5min ~ 900min, step 5 minutes.
11	Float charge voltage	[11] 55.2V default	Float charging voltage, setting range 48V~58.4V, step 0.4V.
12	Over-discharge voltage	[12] 42V default	Over-discharge voltage, the battery voltage is lower than the judgment point, the inverter output will be turned off after the time set in the delay parameter [13], the setting range is 40V~52V, the step is 0.4V.

13	Over-discharge delay time	[13] 5S default	Over-discharge delay time, when the battery voltage is lower than the parameter [12], the inverter output will be turned off after delaying the time set in this parameter, the setting range is 5S~50S, the step is 5S.
14	Battery undervoltage alarm point	[14] 44V default	Battery undervoltage alarm point, when the battery voltage is lower than the judgment point, the under-voltage alarm will be reported and the output will not be shut down, the setting range is 40V~54V, step 0.4V.
15	Battery Discharge Limit Voltage	[15] 40V default	The maximum number of items that can be set is 12, depending on the battery type.
16	Equalize charge	[16] DIS default	Prohibition of equalization charging.
		[16] ENA	Enable equalization charging, only for open lead-acid and sealed lead-acid batteries and for Custom (User).
17	Equalize charging voltage	[17]56.8V default	Equalize charging voltage, setting range 48V~58.4V, step 0.4V, valid for open lead-acid and sealed lead-acid batteries, and valid for customization (User).
18	Equalize charging time	[18] 120S default	Equalization charging time, setting range 5min~900min, step 5 minutes, effective for open lead-acid batteries and sealed lead-acid batteries.
19	Equalization charging delay time	[19] 240min default	Equalization charging delay, setting range 5min~900min, step 5min, valid for open lead-acid batteries and sealed lead-acid batteries, and valid for customization (User).
20	Equalize charge interval	[20] 30 default	Equalization charging interval, 0~30days in 1 day steps, valid for open lead-acid batteries and sealed lead-acid batteries, and valid for customization (User)
21	Equalize Charge Enable	[21] DIS default	Stop equalizing the charge immediately.
		[21] ENA	Immediately initiate equalization charging.
22	Energy saving mode	[22] DIS default	Disable energy saving mode
		[22] ENA	After enabling the energy-saving mode, if the load is empty or less than 50W, the inverter output delays for a period of time and then turns off the output; when the load is greater than 50W, the inverter starts automatically.
23	Overload automatic restart	[23] DIS	Overload automatic restart is prohibited, if an overload occurs shutting down the output, the machine will no longer come back on.
		[23] ENA default	Enable the overload automatic restart function. If an overload occurs, the output will be shut down. The machine will delay for 3 minutes and then restart the output. After it has accumulated 5 overload occurrences, the machine will not be restarted again.
24	Automatic restart in case of over-temperature	[24] DIS	Automatic restart is prohibited in case of overheating. If overheating occurs, the output should be turned off, and the machine will not turn on the output again.
		[24] ENA default	Enable over-temperature auto restart, if over-temperature occurs to turn off the output, it will restart to turn on the output when the temperature drops.
25	Buzzer alarm	[25] DIS	Disabling alarm.
		[25] ENA default	Enabling alarm.
26	Reminder for Mode Conversion	[26] DIS	When the status of the main input source changes, the alarm prompt is prohibited.
		[26] ENA default	Enable alarm indication when the status of the main input source changes.
27	Inverter overload to	[27] DIS	Prohibit automatic switching to grid when inverter is overloaded.

	bypass	[27] ENA default	Automatic switching to grid when inverter is overloaded.
28	Max. AC charging current	[28] 60A default	AC charging max. charging current setting. Setting range 0~60A, default 60A.
30	Communication address setting	[30] 1 default	RS485 communication address settable range 1~254.
31	AC output mode (can be set in the standby mode only)	[31] SIG Default	Single machine setting
		[31] PAL	Single-phase parallel connection setting
		[31] 3P1/3P2/3P3	Three-phase parallel connection setting
		All machines in phase 1 must be set as <b>【3P1】</b> All machines in phase 2 must be set as <b>【3P2】</b> All machines in phase 3 must be set as <b>【3P3】</b> 1. When the output voltage set in the setting <b>【38】</b> is 230Vac (S model) At present the line voltage between the live wire L1 in phase 1 and the live wire L2 in phase 2 is $230 \times 1.732 = 398\text{Vac}$ , and similarly the line voltage between L1-L3, L2-L3 is 398Vac; the single phase voltage between L1-N, L2-N, L3-N is 230Vac.	
32	BMS communication function	[32] SLA default	WIFI port for PC and remote monitoring protocols.
		[32] 485	WIFI port for BMS communication function.
33	BMS communication protocol	When [32] setting item = BMS, you need to select the corresponding lithium battery manufacturer's brand for communication. PAC=PACE, RDA=RITAR, AOG=ALLGRAND, OLT=OLITER, HWD=SUNWODA, DAQ=DYNESS, WOW=SRNE, PYL=PYLONTECH, UOL=VILION	
34	Hybrid banding and grid-connected setup	[34] DIS default	Disable this function.
		[34] Grid	Grid-connected function, in grid mode, the PV is prioritized for charging, and the remaining energy is supplied to the load and fed into the grid.
35	Low voltage disconnect battery voltage recovery point (Fault 04)	[35] 52V default	When the inverter output is disconnected due to low battery voltage, the battery voltage needs to be greater than this set value for the battery inverter's AC output to be restored.
36	PV Max. charge current	[36] 80A default	Solar max. charging current setting: 0~100A
37	Battery recharge recovery point	[37] 52V default	When the battery is fully charged, the inverter stops charging and resumes charging when the battery voltage falls below this voltage value.
38	AC output voltage gear setting	[38] 230Vac default	For models of the S series: The voltage can be set to 200/208/220/230/240Vac, with the default being 230Vac. The AC output power = rated power * (set voltage / 230).
39	Battery charging current limiting mode	[39] BMS default	This mode only takes effect when the inverter communicates successfully with the lithium battery BMS (Battery Management System), and the following options can be set: <b>【SET】</b> When this option is selected, the inverter charging current adopts the value set in item [07], in which case item [07] can be set to any value from 0 to the maximum charging current. <b>【BMS】</b> When this option is selected, the charging limit current transmitted by BMS and the value set in [07] will be compared, and the smaller value will be taken as the current charging current, in this case, the charging current that can be set in [07] can not be greater than the value of the charging limit current of BMS.

			<p>After <b>[INV]</b> is selected, the internal current limit value of the inverter will be compared with the value set in [07], and the smaller value will be taken as the current charging current, at this time, the charging current that can be set in [07] cannot be greater than the internal current limit value of the inverter.</p> <p>The logic for determining the inverter internal current limit value is:</p> <ol style="list-style-type: none"> <li>1. when the battery SOC&gt;98%, the charging current is reduced to 1/16 of the inverter rated charging current value;</li> <li>2. when the battery SOC&gt;95%, the charging current is reduced to the inverter rated charging current 1/8;</li> <li>3. when the battery SOC&gt;90%, the charging current is reduced to 1/4 of the inverter rated charging current value;</li> <li>4. when the battery SOC &gt; 85%, the charging current is reduced to 1/2 of the inverter rated charging current.</li> </ol>
57	Stop charging current	[57]2A default	Charging stops when the charging current is less than the set value.
58	Discharge alarm SOC setting	[58] 15% default	SOC alarm when capacity is less than this setting. (Valid when BMS communication is normal).
59	Discharge cutoff SOC setting	[59] 5% default	Discharge stops when the capacity is less than this setting value. (Valid when BMS communication is normal).
60	Charge cutoff SOC setting	[60]100 % default	When the capacity is greater than this setting, charging stops. (Valid when BMS communication is normal).
61	Switching mains SOC setting	[61] 10 % default	When the capacity is less than this setting value, switch to grid power. (Effective when BMS communication is normal).
62	Switching inverter output SOC setting	[62] 100 % default	When the capacity is greater than the set value, switch to the inverter output mode. (Effective when the BMS communication is normal.) When there is no mains power and the battery SOC is greater than the value set in this item, the second load will be turned on.
63	N-PE connection automatic switching function	ENA default	Automatic switching of N-PE connections is not allowed.
		DIS	Allows automatic switching of N-PE connections.

## 4.3 Battery type parameter table

Lead-acid batteries :

Battery type Parameters	Sealed lead acid battery (SLD)	Gel lead acid battery (GEL)	Flooded lead acid battery (FLD)	User-defined (USER)
Overvoltage disconnect voltage	60V	60V	60V	36 ~ 60V (adjustable)
Recharge recovery voltage after full charge	52V (adjustable)	52V (adjustable)	52V (adjustable)	52V (adjustable)
Equalize charging voltage	58.4V	56.8V	59.2V	36 ~ 60V (adjustable)
Boost charging voltage	57.6V	56.8V	58.4V	36 ~ 60V (adjustable)
Float charging voltage	55.2V	55.2V	55.2V	36 ~ 60V (adjustable)
Undervoltage warning voltage (01 fault)	44V	44V	44V	36 ~ 60V (adjustable)
Undervoltage alarm recovery voltage (01 fault)	Undervoltage alarm voltage +0.8V			
Low voltage disconnect voltage (04 Fault)	42V	42V	42V	36 ~ 60V (adjustable)
Low voltage disconnect recovery Voltage(04 fault)	52V (adjustable)	52V (adjustable)	52V (adjustable)	52V (adjustable)
Discharge limiting voltage	40V	40V	40V	36 ~ 60V (adjustable)
Over-discharge delay time	5s	5s	5s	1 ~ 30s (adjustable)
Equalization duration	120 minutes	-	120 minutes	0 ~ 600 minutes (adjustable)
Equalization charging interval	30days	-	30days	0 ~ 250 days (adjustable)
Boost Charge Duration	120 minutes	120 minutes	120 minutes	10 ~ 600 minutes (adjustable)

**Lithium battery :**

Battery type Parameters	Ternary (N13)	Ternary (N14)	LFP (L16)	LFP (L15)	LFP (L14)
Overvoltage disconnect voltage	60V	60V	60V	60V	60V
Re-establish charging voltage after full charging (37 setting items)	50.4V (adjustable)	54.8V (adjustable)	53.6V (adjustable)	50.4V (adjustable)	47.6V (adjustable)
Equalize charging voltage	53.2V (adjustable)	57.6V (adjustable)	56.8V (adjustable)	53.2V (adjustable)	49.2V (adjustable)
Boost charging voltage	53.2V (adjustable)	57.6V (adjustable)	56.8V (adjustable)	53.2V (adjustable)	49.2V (adjustable)
Float charging voltage	53.2V (adjustable)	57.6V (adjustable)	56.8V (adjustable)	53.2V (adjustable)	49.2 (adjustable)
Undervoltage warning voltage (01 fault)	43.6V (adjustable)	46.8V (adjustable)	49.6V (adjustable)	46.4V (adjustable)	43.2V (adjustable)
Undervoltage alarm recovery voltage(01 fault)	Undervoltage alarm voltage +0.8V				
Undervoltage disconnect voltage(04 fault)	38.8V (adjustable)	42V (adjustable)	48.8V (adjustable)	45.6V (adjustable)	42V (adjustable)
Low voltage disconnect recovery voltage (04 fault) (35 setting items)	46V (adjustable)	49.6V (adjustable)	52.8V (adjustable)	49.6V (adjustable)	46V (adjustable)
Discharge limiting voltage	36.4V	39.2V	43.6V	43.6V	40.8V
Over-discharge delay time	30s (adjustable)	30s (adjustable)	30s (adjustable)	30s (adjustable)	30s (adjustable)
Boost charge duration	120 minutes (adjustable)	120 minutes (adjustable)	120 minutes (adjustable)	120 minutes (adjustable)	120 minutes (adjustable)

## 5. Other function

### 5.1 Dry node function

**Working principle:** This dry junction can control the diesel generator switch to charge the battery.

① Under normal conditions, this terminal is closed at the NC-N point and disconnected at the NO-N point.

② When the battery voltage reaches the low-voltage disconnection voltage point, the coil of the relay is energized and NO-N point is closed and NC-N point opened. At this time, NO-N point can drive resistive loads 125VAC/1A, 230VAC/1A and 30VDC/1A.

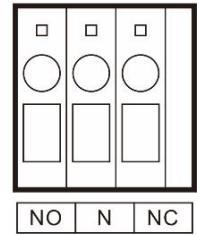

### 5.2 RS485 communication function

This port is an RS485 communication port. There are two ports, RS485 and WIFI.

RS485 communication port with 2 roles:

① It is possible to directly carry out RS485 communication with the Lithium Battery BMS through the RS485 port.

② RS485/WIFI can also be connected and used with the RS485-to-WIFI/GPRS communication module independently developed by our company and optionally configured through this port. After the module is optionally configured, the integrated inverter and controller of our company can be connected via the mobile APP. Through the mobile APP, the operation parameters and status of the integrated inverter and controller can be viewed.

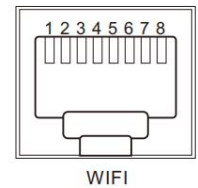
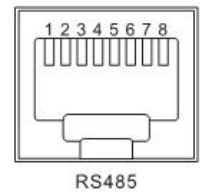

**The pin definitions are as shown in the figure:**

RS485: Pin 7 is for RS485-A, and Pin 8 is for RS485-B.

WIFI: Pin 1 is the 5V power supply, Pin 2 is the ground (GND), Pin 7 is for RS485-A, and Pin 8 is for RS485-B.

### 5.3 USB communication function

CAN port for CAN communication with Li-ion battery BMS. The pins are defined as shown in the figure:

Pin 4 is CANH Pin 5 is CANL

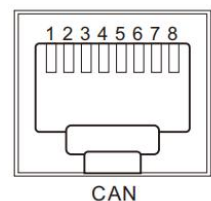

### 5.4 USB communication function

This port is a USB communication port, you can use this port to communicate with the optional software of our company's host computer (need to be applied for), and you need to install the corresponding "USB to Serial Chip CH340T Driver" in your computer to use this port.

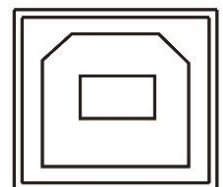

## 6. Protection

### 6.1 Protection features available

No.	Protection function	Note
1	PV current limit/power limit protection	When the configured PV array charging current exceeds the PV rated current, it will be charged at the rated current.
2	PV night time anti-reverse charge protection	At night, the battery is prevented from discharging through the PV module because the voltage of the battery is greater than the voltage of the PV module.
3	Grid input over-voltage protection	When the mains voltage exceeds 280V (230V model), the grid charging will be stopped and the output will be inverted.
4	Grid input undervoltage protection	When the mains voltage falls below 170V (230V model/UPS mode), the grid charging will be stopped and the output will be inverted.
5	Battery overvoltage protection	When the battery voltage reaches the over-voltage disconnect voltage point, it will automatically stop the PV and grid charging of the battery to prevent over-charging and damage to the battery.
6	Battery undervoltage protection	When the battery voltage reaches the low voltage disconnect voltage point, it will automatically stop discharging the battery to prevent the battery from being damaged by over-discharge.
7	Load output short circuit protection	When a short-circuit fault occurs at the load output for more than 200 MS, it immediately shuts down the output AC voltage.
8	Radiator over-temperature protection	When the internal temperature of the all-in-one machine is too high, the all-in-one machine will stop charging and discharging. When the temperature returns to normal, the all-in-one machine will resume charging and discharging.
9	Overload protection	<p>Inverter overload protection logic:</p> <p>Primary load (102%&lt;load&lt;125%) ±10%: report an error and shut down the output after 5 minutes.</p> <p>Secondary load (102%&lt;load&lt;125%) ±10%: error report and shutdown after 2.5 minutes.</p> <p>Primary load (125%&lt;load&lt;150%) ±10%: error and shutdown after 10 seconds;</p> <p>Secondary load (125%&lt;load&lt;150%) ±10%: reports an error and shuts down the output after 5 seconds;</p> <p>Primary load &gt; 150% ±10%: error and shutdown after 5 seconds;</p> <p>Secondary load &gt; 150% ±10%: error and shutdown after 2.5 seconds ;</p> <p>Bypass overload is calculated as 100% of relay current 40A;</p> <p>Primary load (97%&lt;load&lt;100%): report error and shut down output after 5 minutes.</p> <p>Secondary load (97%&lt;load&lt;100%) : Report an error and turn off the output after 2.5 minutes.</p> <p>Primary load (100%&lt;load&lt;102%): report an error and shut down the output after 10 seconds;</p> <p>Secondary load (100%&lt;load&lt;102%) : reports an error and shuts down the output after 5 seconds;</p> <p>Primary load &gt;102% load: reports an error and shuts down the output after 5 seconds;</p> <p>Secondary load &gt;102% load: error and shutdown after 2.5 seconds;</p>
10	PV anti-reverse protection	Machine will not be damaged when PV polarity is reversed.
11	AC backfill protection	Prevents backfeeding of battery inverter AC power to the bypass AC input. (in non-grid-connected mode)
12	Bypass overcurrent protection	Built-in AC input overcurrent protection circuit breaker.
13	Battery input overcurrent protection	When the battery discharge output current is greater than the maximum value and lasts for 1 minute, the trans AC input is loaded.
14	Charging short circuit protection	The inverter protects and stops the output current when the external battery port is short-circuited during PV or AC charging state.

## 6.2 Meaning of fault code

Fault Code	Fault Name	Affecting output or not	Note
【01】	BatVoltLow	No	Low Battery Alarm.
【02】	BatOverCurrSw	Yes	Battery discharge average current overcurrent software protection.
【03】	BatOpen	Yes	Battery not connected alarm.
【04】	BatLowEod	Yes	Low battery voltage stop discharging alarm.
【05】	BatOverCurrHw	Yes	Battery overcurrent hardware protection.
【06】	BatOverVolt	Yes	Charge overvoltage protection
【07】	BusOverVoltHw	Yes	Internal battery boost circuit overvoltage hardware protection.
【08】	BusOverVoltSw	Yes	Internal battery boost circuit overvoltage software protection.
【09】	PvVoltHigh	No	Solar Input Voltage Overvoltage Protection.
【10】	PvOCSw	No	Solar charging overcurrent software protection.
【11】	PvOCHw	No	Solar charging overcurrent hardware protection.
【13】	OverloadBypass	Yes	Bypass AC Output Overload Protection.
【14】	OverloadInverter	Yes	Inverter AC Output Overload Protection.
【15】	AcOverCurrHw	Yes	Inverter AC Output Overcurrent Hardware Protection.
【17】	InvShort	Yes	Inverter AC Output Short Circuit Protection.
【19】	OverTemperMppt	No	Solar charging radiator over-temperature protection.
【20】	OverTemperInv	Yes	Inverter AC output load or AC charging radiator over-temperature protection.
【21】	FanFail	Yes	Fan blocking or failure fault.
【22】	EEPROM	Yes	Memory failure.
【23】	ModelNumErr	Yes	Model setting error.
【26】	RlyShort	Yes	Inverter AC output backfeed to bypass AC input.
【29】	BusVoltLow	Yes	Low bus voltage protection.
【30】	BatCapacityLow1	No	Battery capacity rate below 10% alarm (Set BMS enable active).
【31】	BatCapacityLow2	No	Battery capacity rate below 5% alarm (Set BMS to enable).
【32】	BatCapacityLowStop	Yes	Battery low capacity shutdown (Set BMS to enable).
【41】	InvDcVoltErr	Yes	Abnormal DC component of inverter voltage.
【44】	Serial number error	Yes	Serial number not set at factory.
【58】	BMS Communication Error	No	Check whether the communication cable is correctly connected and

			whether [33] is set to the corresponding lithium battery communication protocol.
【59】	BMS alarm	No	Clear lithium battery faults after viewing the lithium battery BMS fault type.
【60】	BMS battery Low Temperature alarm	No	Lithium battery BMS low temperature alarm.
【61】	BMS battery over-temperature alarm	No	Lithium battery BMS over temperature alarm.
【62】	BMS battery overcurrent alarm	No	Lithium battery BMS battery overcurrent alarm.
【63】	BMS battery under voltage alarm	No	Lithium battery BMS battery undervoltage alarm.

## 6.3 Partial troubleshooting measures

Fault	Solving Measures
No display on screen	Check whether the battery air switch or PV air switch is closed; whether the switch is in "on" state; press any key on the screen to exit from the screen sleep mode.
Charge battery overvoltage protection	Check to see if the battery voltage exceeds the protection value. If exceeded, the battery needs to be discharged until the voltage is below the battery overvoltage recovery point.
Battery undervoltage protection	Allow the battery to charge back up to above the low voltage disconnect recovery voltage.
Fan fault	Check to see if the fan isn't spinning or if it's blocked by something else.
Radiator overtemperature protection	When the device cools below the overtemperature recovery temperature, it shall restore to normal charge and discharge control.
Bypass overload protection, inverting overload protection	① Decrease consumer; ② Restart all-in-one machine and the load output is restored.
Inverting short-circuit protection	① Carefully check load connection condition, clear short-circuit fault point; ② After power on again, the load output is restored.
PV overvoltage	Use a multimeter to check that the PV input voltage does not exceed the maximum allowable input voltage.
No connection alarm of battery	Check if the battery is not connected or if the battery side circuit breaker is not closed.

## 7. System maintenance

➤ To maintain optimum long-lasting operating performance, it is recommended that the following items be inspected twice a year.

- ① Confirm that airflow around the all-in-one unit is not blocked by removing any dirt or debris from the radiator.
- ② Check that all exposed wires are not damaged due to sunlight, friction with other surrounding objects, dry rot, insect or rodent damage, etc. resulting in damaged insulation, repair or replace wires if necessary.
- ③ Verify that the indications and displays are consistent with the operation of the equipment, note any malfunctions or incorrect displays take corrective action if necessary.
- ④ Check all terminals for signs of corrosion, insulation damage, high temperature or burning/discoloration, tighten terminal screws.
- ⑤ Check for dirt, nesting insects and corrosion, clean as required.
- ⑥ If the lightning arrester has failed, promptly replace the failed arrester to prevent causing lightning damage to the MFP or even other equipment of the user.

**Warning: Danger of electric shock! When performing the above operations, make sure that all power supplies to the MFP are disconnected and that the capacitors are fully discharged before performing the corresponding checks or operations!**

➤ **We are not responsible for damage caused by the following:**

- ① Damage caused by improper use or use in an unsuitable place.
- ② Damage caused by the open circuit voltage of the PV module exceeding the maximum allowable voltage.
- ③ Damage caused by the operating environment temperature exceeding the limitation of the operating temperature range.
- ④ disassembling and repairing the MFP privately.
- ⑤ damage caused by force majeure: damage occurring during transportation or loading/unloading of the MFP.

## 8. Technical parameter

Model	AFP4850S100-H
<b>Parallel Operation Mode</b>	
Number of Parallel Units	1~6 units
<b>Grid Mode</b>	
Rated Input Voltage	220/230Vac
Input Voltage Range	90Vac~280Vac(±2%)
Frequency	50Hz/ 60Hz (auto-detect)
Overload and Short - Circuit Protection	Circuit Breaker
Maximum Efficiency	>95%
Conversion Time (bypass and inverter)	10ms (typical)
Protection Against AC Backflow	Yes
Max. Bypass Overload Current	40A
<b>Inverter Mode</b>	
Output Voltage Waveform	Pure sine wave
Rated Output Apparent Power(VA)	5000
Rated Output Active Power(W)	5000
Power Factor	1
Rated Output Voltage (Vac)	230Vac
Output Voltage Tolerance	±5%
Output Frequency Range(Hz)	50Hz ± 0.3Hz/60Hz ± 0.3Hz
Max. Efficiency	>92%
Overload Protection	Overload protection logic: (102%<load<125%) ±10%: reporting an error and shutting down the output after 5 minutes. (125%<load<150%) ±10%: error and shutdown after 10 seconds; (125%<load<150%) ±10%: error report and shutdown after 5 seconds;
Peak Power	10000VA
With Loaded Motor Capacity	4HP
Output Short-Circuit Protection	Circuit Breaker
Bypass Circuit Breaker Specifications	40A
Rated Battery Input Voltage	48V ( Min. Startup Voltage 44V)
Battery Voltage Range	40.0Vdc~60Vdc ± 0.6Vdc (Under-voltage alarm / Shutdown voltage / Over-voltage alarm / Over-voltage recovery... can be set on the LCD

	screen)
Power-saving Mode	Load $\leq 50W$
<b>Grid Output (AC)</b>	
Rated Power(W)	5000W
Maximum Apparent Power ( VA )	5000VA
Maximum Output Current ( A )	21.7A
THDI	< 3%
Rated Voltage	230Vac
Rated Frequency	50Hz/60Hz
<b>Grid Charging</b>	
Battery Type	Lead-acid or lithium batteries
Maximum Charge Current (settable)	60A
Charging Current Error	$\pm 3A_{dc}$
Charging Voltage Range	40~58Vdc
Short-Circuit Protection	Circuit Breaker and Fuse
Circuit Breaker Specification	40A
Overcharge Protection	Alarms and shuts off charging after 1 minute
<b>Solar Charging</b>	
Maximum PV Open - Circuit Voltage	500Vdc
MPPT Voltage Range	60~450Vdc
Battery Voltage Range	40~60Vdc
Maximum PV Input Power	7500W
Maximum PV Input Current	22A
Solar Charging Current Range (Settable)	0~100A
Charging Short - Circuit Protection	Blown Fuse
Wiring Protection	Reverse connection protection
<b>Maximum Hybrid Charging Current (PV+AC)</b>	
Maximum Hybrid Charging Current (Settable)	0~100A
Certification Specifications	
Specification Certification	IEC62109-1, IEC62109-2
EMC Certification Level	EN61000-6-1, EN61000-6-3, FCC 15 class B

Operating Temperature Range	-15°C ~ 55°C , > 45°C derate
Storage Temperature Range	-25°C ~ 60°C
Humidity Range	5% to 95%(Protected by three-proof paint)
Noise	≤60dB
Heat Dissipation	Forced air cooling with adjustable air speed
Communication Interface	USB/RS485/WiFi/dry node control
Dimensions (L*W*D)	359.5mm*210mm*133mm
Weight ( kg )	10