

User Manual



All-in-One Solar Charge Inverter

AEP4860S135-H

CONTENTS

1. Safety Precautions	1
1.1 How to Use This Instruction Manual	1
1.2 Symbols in this manual	1
1.3 Safety Instructions	1
2. Product Introduction	2
2.1 Product Description	2
2.2 Product Features	2
2.3 System Connection Diagram	3
2.4 Product Overview	4
2.5 Product Size	5
3. Installation	6
3.1 Parts List	6
3.2 Mounting Instructions	7
3.2.1 Installation Location Selection	7
3.2.2 Mounting the Inverter	8
3.2.3 Removing the Terminal Protection Cover	9
4. Connection Instructions	9
4.1 Single-phase Mode	9
4.2 Cable & Circuit Breaker Requirement	11
4.3 GRID & LOAD & Generator Connection	12
4.4 Battery Connection	13
4.5 PV Connection	13
4.6 Dry Contact Connection	15
4.7 Grounding Connection	16
4.8 Final Installation	16
4.9 Parallel Connection	16
4.9.1 Introduction to Parallel Connection	16
4.9.2 Precautions for Connecting the Parallel Connecting Lines	17
4.9.3 Schematic Diagram for Single-Phase Parallel Connection	19
4.9.4 Schematic Diagram for Three-Phase Parallel Connection	21
5. Operation	24
5.1 Operation and Display Panel	24
5.2 Setting Parameters	27
5.3 AC Output Mode	36
5.4 Battery Charging Mode	38
5.5 Time-slot Charging and Discharging Function	39
5.6 Battery Parameters	40
5.6.1 Lead-Acid Battery	40
5.6.2 Lithium-ion Battery	40
6. Communication	41
6.1 Product Overview	41
6.2 RS485/CAN Communication Function	41
6.3 WiFi Communication (Optional)	42
6.4 USB Communication Function	42
6.5 Meter Communication (Optional)	43
6.6 Parallel Communication Function	44
6.7 Dry Contact Function	44
6.8 External CT Communication (Optional)	45
6.9 DIP Switch Configuration	46
7. Fault Codes and Countermeasures	47
7.1 Fault Codes	47
7.2 Partial Troubleshooting	48
8. Protection and Maintenance	49
8.1 Protection Functions	49
8.2 Maintenance	51
9. Datasheet	52





1. Safety Precautions

1.1 How to Use This Instruction Manual

The manual mainly describes the product information, installation guidelines, operation instructions, maintenance instructions for the AEP4860S135-H.

Read the manual and other related documents before performing any operation on the inverter. Documents must be stored carefully and be available at all times.

1.2 Symbols in this manual

 DANGER	DANGER indicates a hazardous situations which if not avoided will result in death or serious injury.
 WARNING	WARNING indicates a hazardous situations which if not avoided could result in death or serious injury.
 CAUTION	CAUTION indicates a hazardous situations which if not avoided could result in minor or moderate injury.
 NOTICE	NOTICE provide some tips on operation of products.

1.3 Safety Instructions

WARNING: This chapter contains important safety and operating instructions. Read and keep this manual for future reference.

- Be sure to comply the local requirements and regulation to install this inverter.
- Beware of high voltage. Please turn off the switch of each power sources before and during the installation to avoid electric shock.
- For optimum operation of this inverter, please follow required specification to select appropriate cable size and necessary protective device.
- Do not connect or disconnect any connections when the inverter is working.
- Do not open the terminal cover when the inverter working.
- Make sure the inverter is well grounding.
- Never cause AC output and DC input short circuited.
- Do not disassembly this unit, for all repair and maintenance, please take it to the professional service center.
- Never charge a frozen battery.
- Please keep children away from touching or mishandling the inverter.
- Please make sure that this inverter is the only input power source for the load, do not use it in parallel with other input AC power sources to avoid damage. Ensure this inverter is the sole input power source for the load. Do not parallel it with other AC input power sources to avoid damage.

2. Product Introduction

2.1 Product Description

The AEP series is a new type of photovoltaic energy storage inverter integrating photovoltaic and grid charging functions, with AC sine wave output. It adopts DSP control and advanced control algorithms, featuring high response speed, high reliability, and industrial-grade standards.

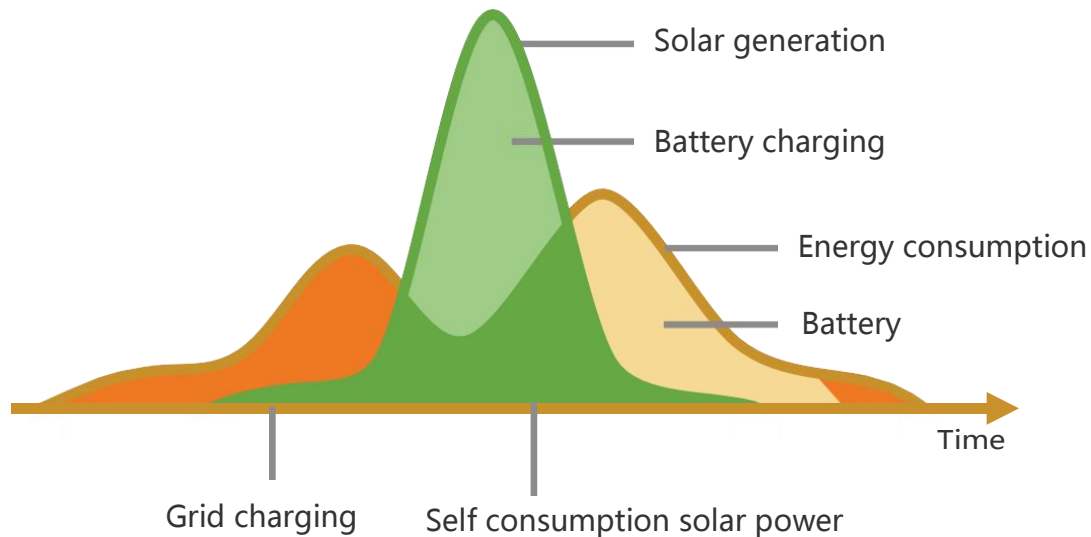

2.2 Product Features

- Supports connection to various types of energy storage batteries, including lead-acid batteries and lithium-ion batteries.
- With a dual activation function when the li-ion battery is dormant; either mains/ photovoltaic power supply access can trigger the activation of the li-ion battery.
- Supports split-phase pure sine wave output of 200~240V.
- Supports phase voltage adjustment within the range of 200Vac, 208Vac, 220Vac, 230Vac, and 240Vac.
- Dual MPPT with 99.9% efficiency and maximum 22A current in a split circuit, perfectly adapted to high power modules.
- 2 charging modes are available: PV only, grid+PV charging.
- The grid supports time-of-use charge and discharge settings, helping customers leverage TOU electricity prices to reduce power costs.
- Energy saving mode function to reduce no-load energy losses.
- With two output modes of utility bypass and inverter output, with uninterrupted power supply function.
- HOME LOAD operation mode with external load anti-backflow function.
- Generator interface compatible with intelligent load function.
- Independent generator interface enabling flexible switching between mains and generator power.

- Generator peak-shaving function effectively reducing generator load pressure, avoiding generator overload risks, and ensuring stable and reliable power supply.
- LCD large screen dynamic flow diagram design, easy to understand the system data and operation status.
- 360° protection with complete short circuit protection, over current protection, over under voltage protection, overload protection, backfill protection, etc.
- Support CAN, USB, and RS485 communication.

2.3 System Connection Diagram

The diagram below shows the system application scenario of this product. A complete system consists of the following components:

- **PV Modules:** Converts light energy into DC energy, which can be used to charge the battery via an inverter or directly inverted into AC power to supply the load.
- **Grid:** Connected to the mains AC input, supplying power to loads while charging batteries. The system can operate off-grid when batteries and PV modules power the loads.
- **Battery:** The role of the battery is to ensure the normal power supply of the system loads in case of insufficient photovoltaic and no utility power.
- **Home Load:** Connects to a variety of home and office loads including refrigerators, lamps, TVs, fans, air conditioners and other AC loads.
- **Generator/Smart Load:** When connected to an AC generator, supplies power to loads and charges batteries simultaneously. Without generator connection, this interface can be configured as a Smart Load output to power loads.
- **Inverter:** It is the energy conversion device of the whole system.

Note: The actual application scenario determines the specific system wiring method.

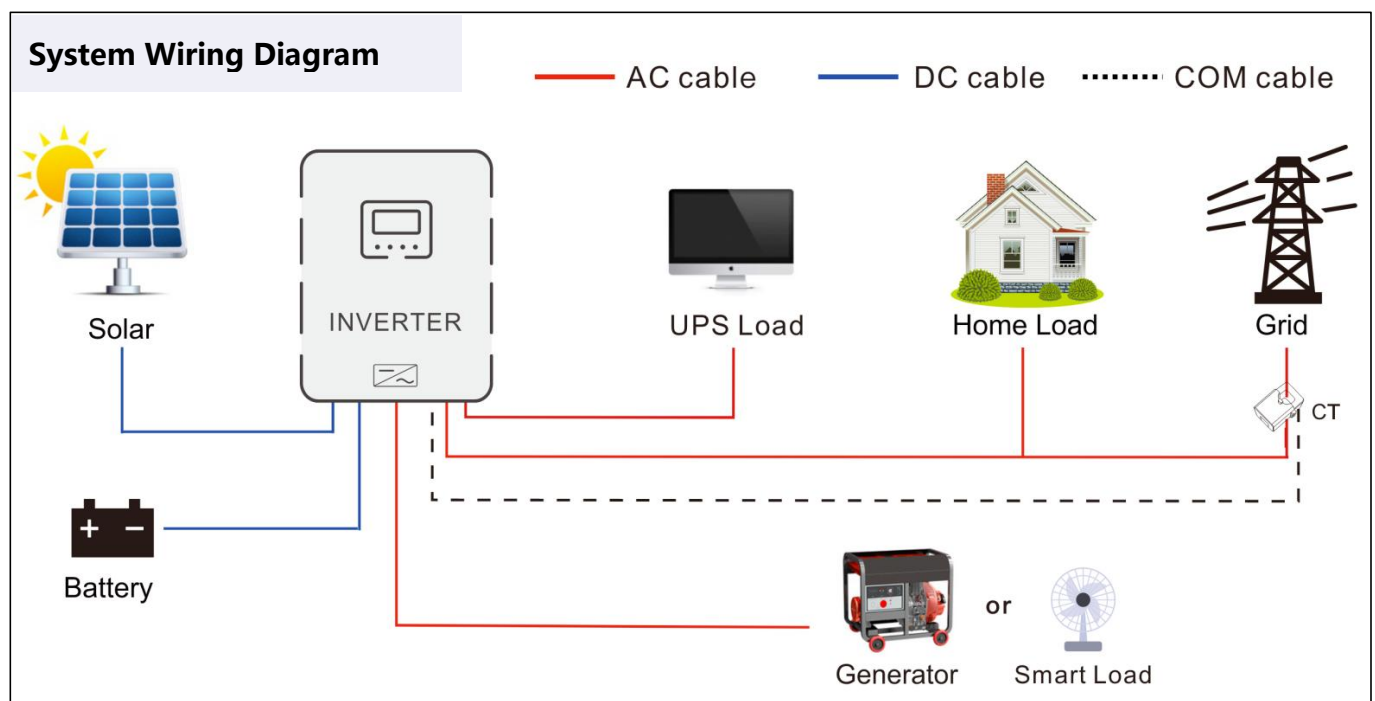

2.4 Product Overview

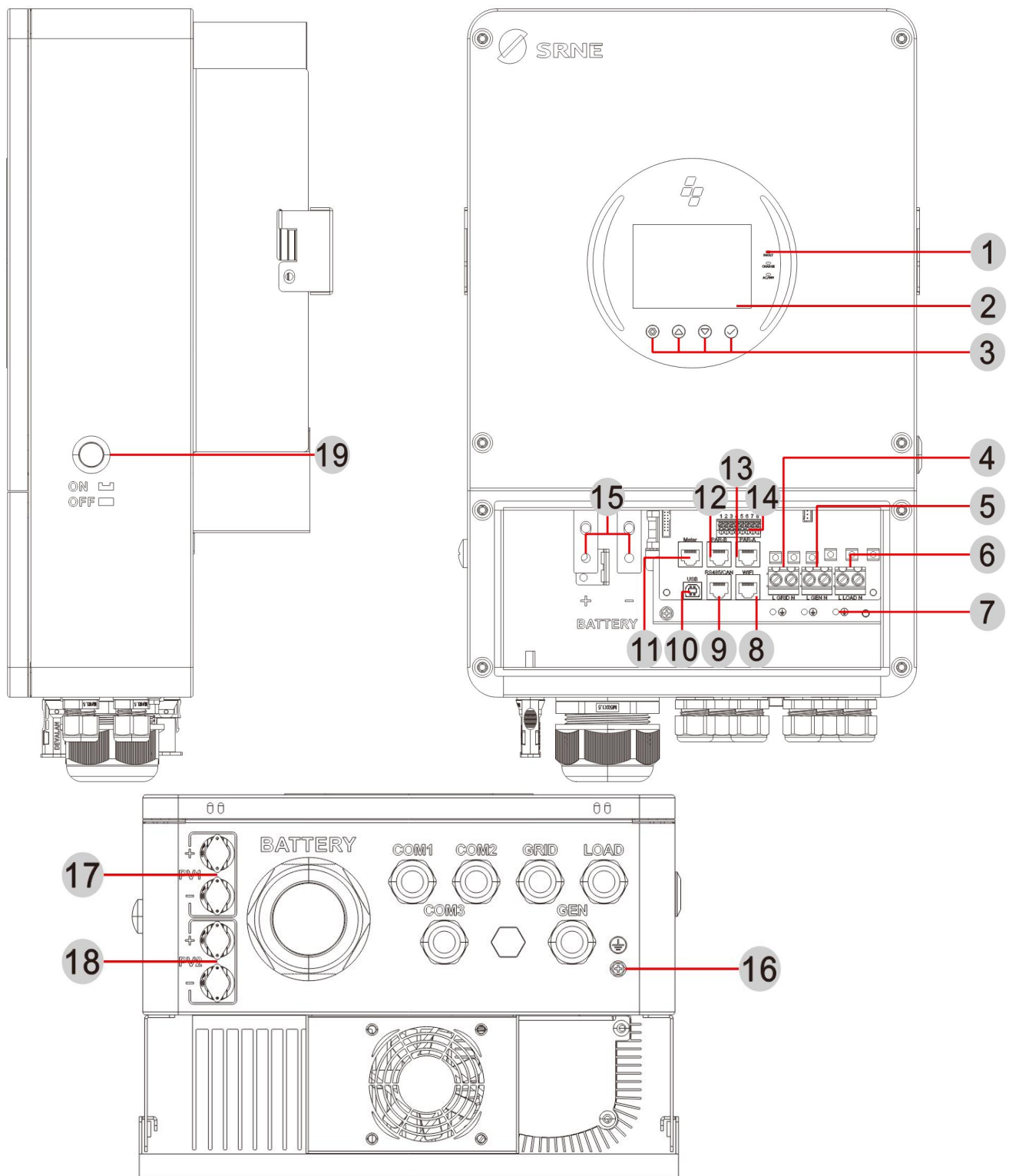

1	LED Indicators	2	LCD Screen	3	Physical Buttons	4	Grid Input (L+N)
5	Generator Input (L+N)	6	Load Output (L+N)	7	Grid/Load/Generator Ground	8	WiFi Port
9	RS485/CAN Port	10	USB Port	11	Meter Port	12	Paralle Port B
13	Paralle Port A	14	Dry Contact	15	Battery Input	16	Machine Ground Wire Interface
17	PV1 Input	18	PV2 Input	19	ON/OFF Switch		



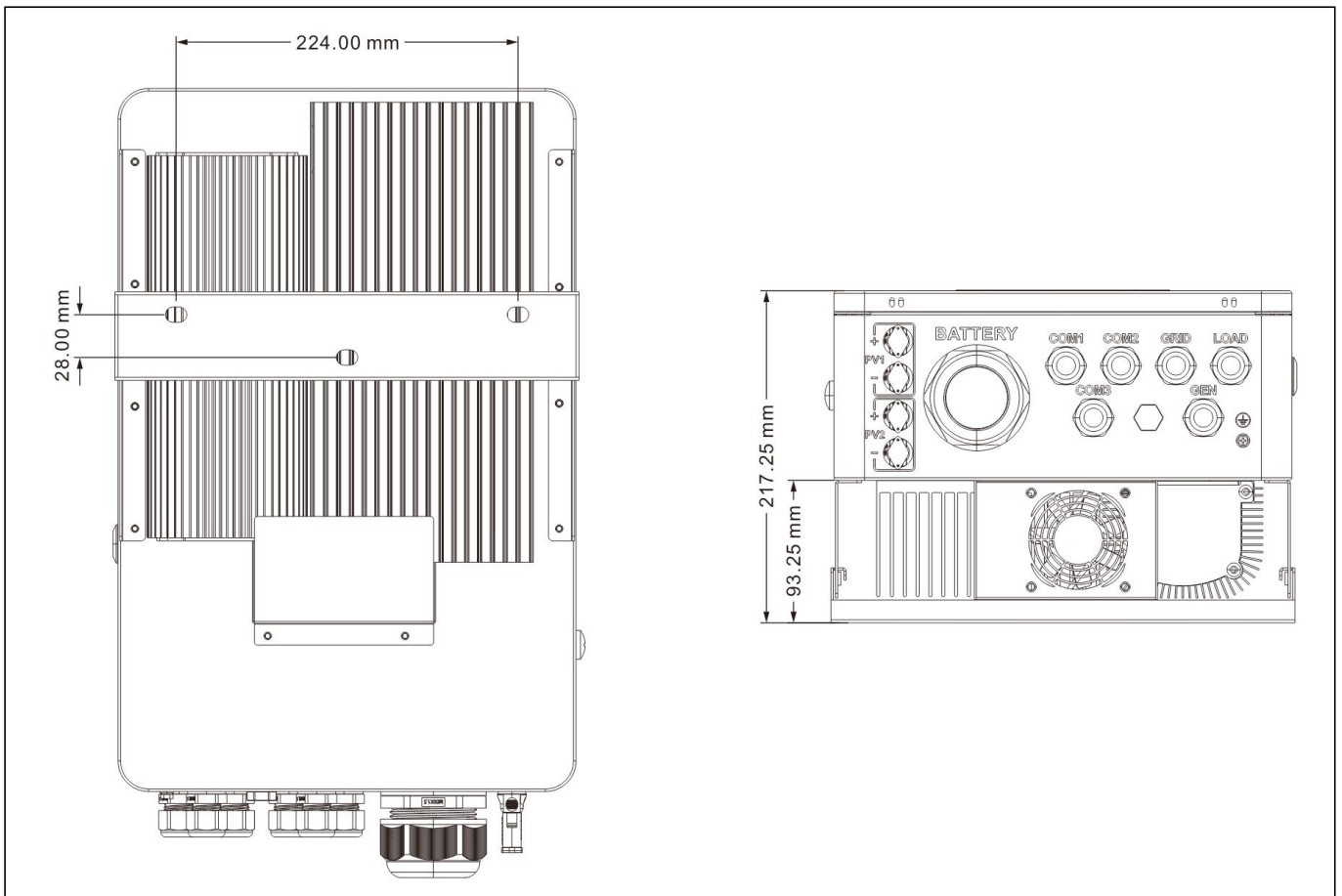
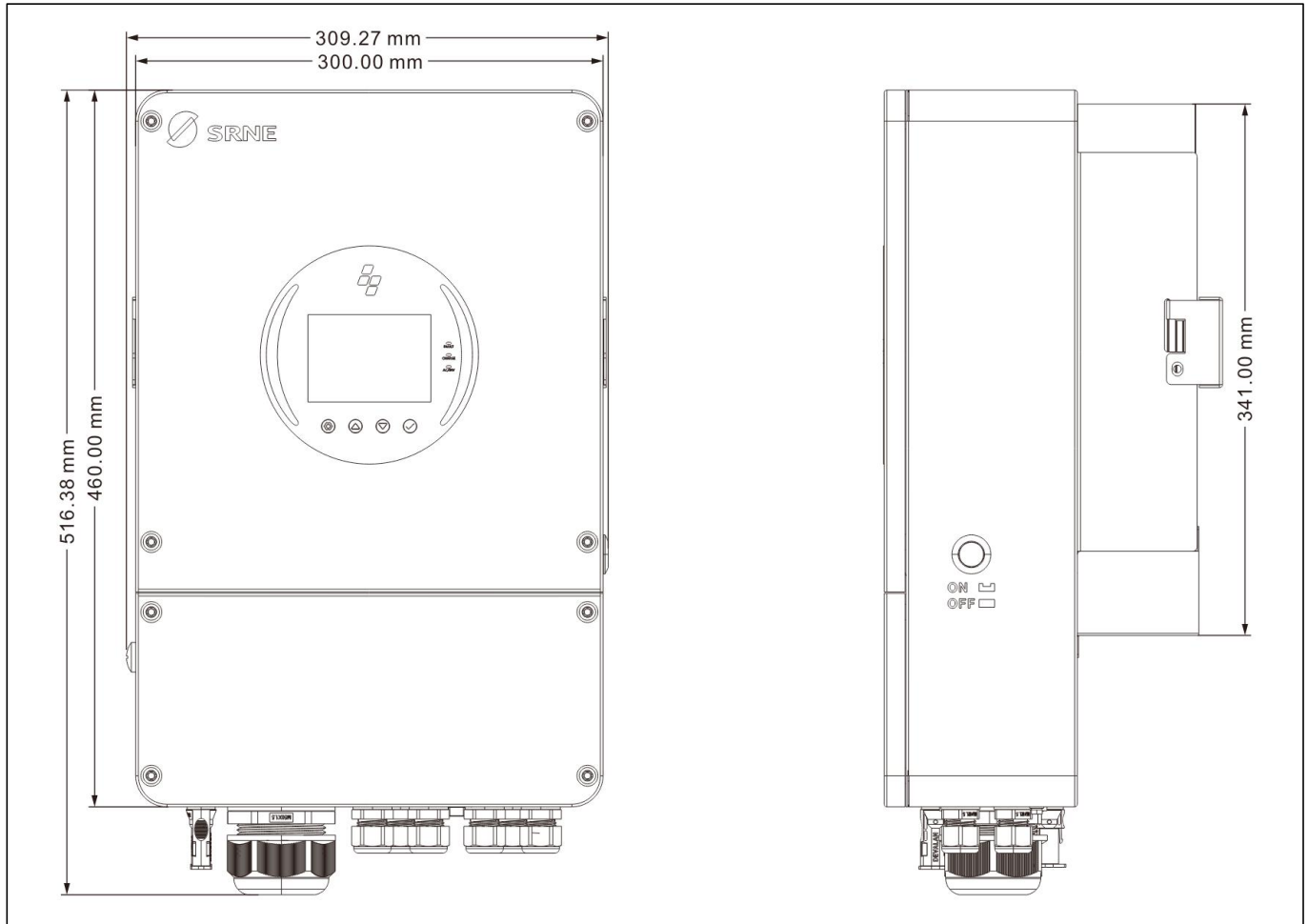

2.5 Product Size

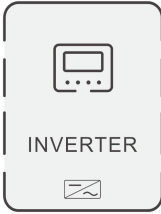

3. Installation

3.1 Parts List

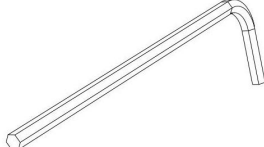
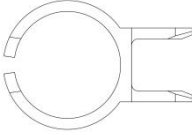
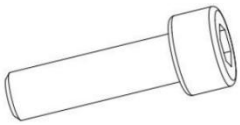
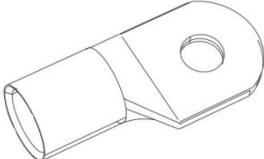
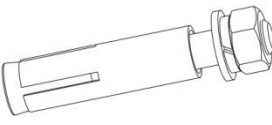
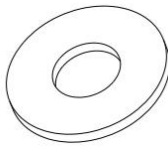
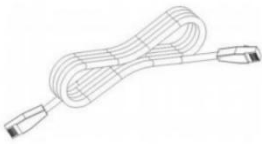
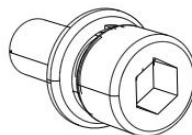
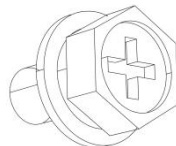
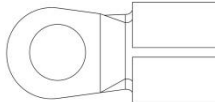
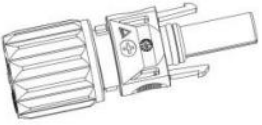
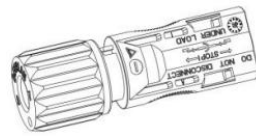
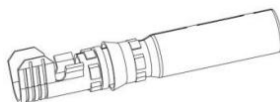
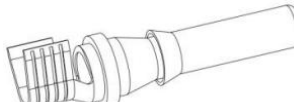
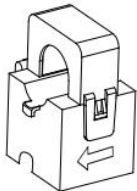
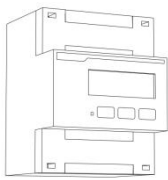
Please check the equipment before installation. Make sure that there is no damage to the packaging. You should have received the following items in the package:

 <p>Inverter x 1pcs</p>	 <p>Wall mount bracket x 1pcs</p>	 <p>Hex Key_L-Type_4mm x 1pcs</p>	 <p>MC4 unlocking tool x 1pcs</p>
 <p>Spare screw M5x18mm x 1pcs</p>	 <p>Crimp Terminal SC35-6 x 2pcs</p>	 <p>Expansion bolt M8x60mm x 3pcs</p>	 <p>M8 flat washer x 3pcs</p>
 <p>Parallel connection cable x 1pcs</p>	 <p>Socket cap screw M5x12mm (triple combination) x 2pcs</p>	 <p>Hexagon socket cross recessed screw M6x10mm x 2pcs</p>	 <p>OT terminal x 3pcs</p>
 <p>PV+ terminal x 2pcs</p>	 <p>PV- terminal x 2pcs</p>	 <p>PV+ input metal core x 2pcs</p>	 <p>PV- input metal core x 2pcs</p>
 <p>CT (Optional) x 1pcs</p>	 <p>Three-phase meter (Optional) x 1pcs</p>	 <p> User manual x 1pcs Quality certificate x 1pcs Outgoing inspection report x 1pcs Warranty Card x 1pcs </p>	

3.2 Mounting Instructions

3.2.1 Installation Location Selection

The AEP inverter can be used outdoors (protection class IP65). Please consider the followings before selecting the location :

- Choose the solid wall to install the inverter.
- Mount the inverter at eye level.
- Adequate heat dissipation space must be provided for the inverter.
- The ambient temperature should be between $-40^{\circ}\text{C} \sim 60^{\circ}\text{C}$ ($-40^{\circ}\text{F} \sim 140^{\circ}\text{F}$) to ensure optimal operation.

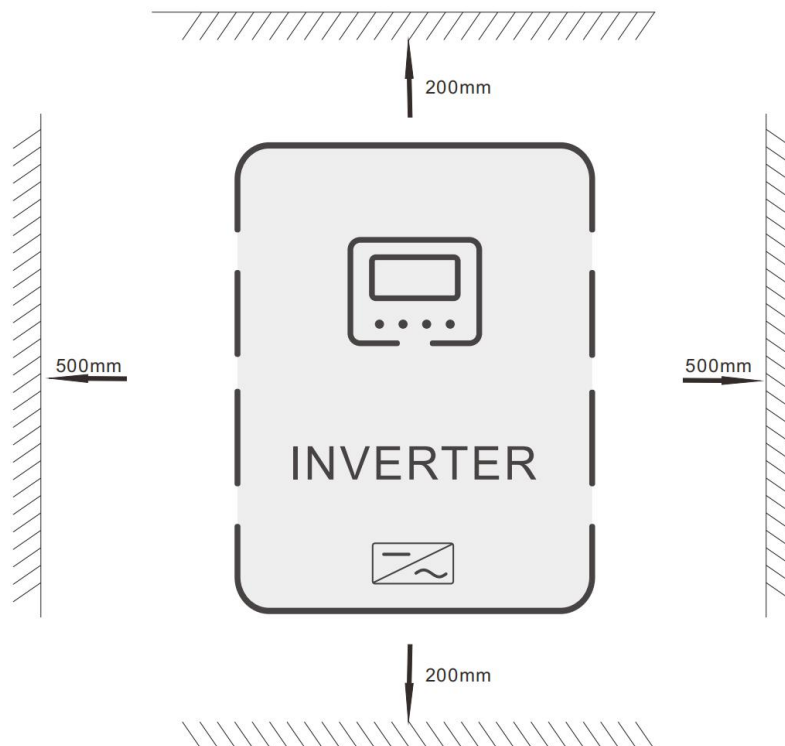

DANGER

- Do not install the inverter where highly flammable materials are near by.
- Do not install the inverter in potential explosive areas.
- Do not install the inverter with lead-acid batteries in a confined space.

CAUTION

- Do not install the inverter in direct sunlight.
- Do not install or use the inverter in a humid environment.

3.2.2 Mounting the Inverter

- **Step 1:** Determine the positions for drilling holes, ensure the position of holes are level, then mark them with a marker pen, use the hammer drill to drill holes on the wall. Keep the hammer drill perpendicular to the wall, do not shake when drilling, so as not to damage the wall. If the error of the hole is too big, you need to reposition.
- **Step 2:** Insert M8*60 expansion bolt vertically into the hole and pay attention to the insertion depth of the expanding bolt (should be deep enough)
- **Step 3:** Align the wall hanger with the position of holes, fix the wall hanger on the wall by tightening the expansion bolt with nuts.
- **Step 4:** Hang the inverter on the wall hanger first, and then fix the inverter and the wall hanger with M5 hexagon socket screws.

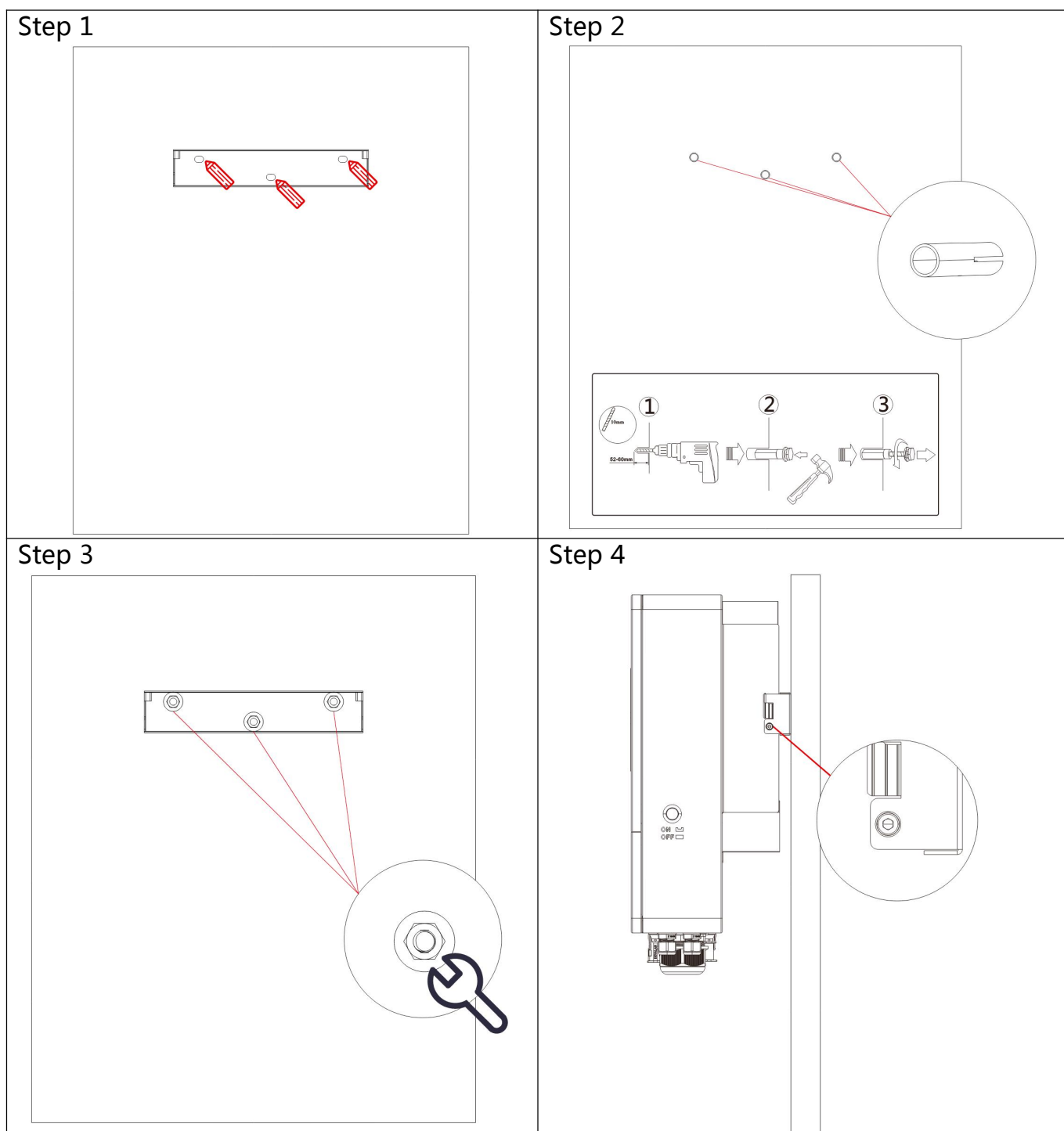

3.2.3 Removing the Terminal Protection Cover

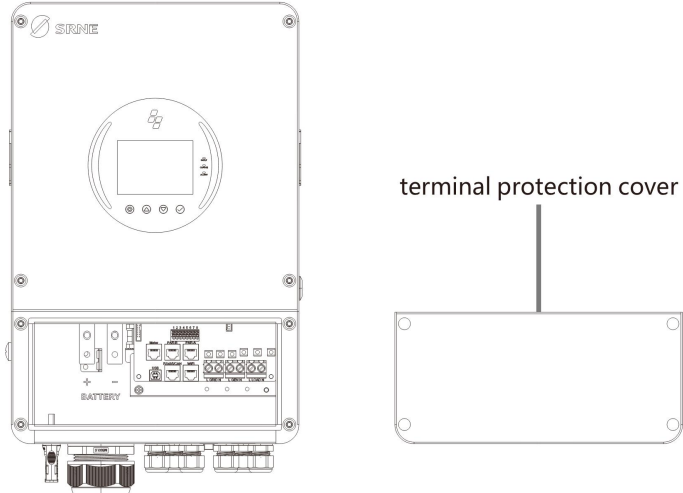
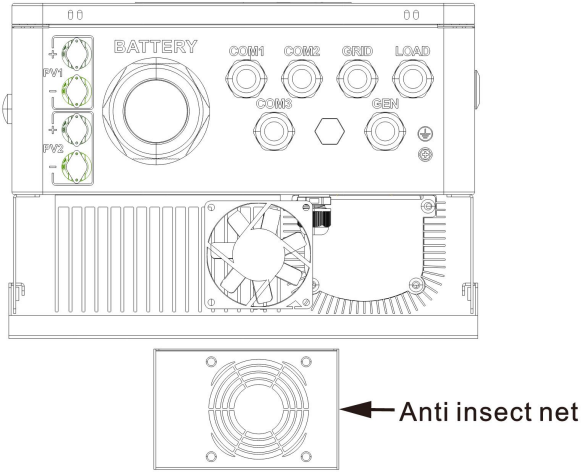
Using a screwdriver, remove the terminal protection cover.	Insect screen can be removed for cleaning.
	

NOTICE

In areas with poor air quality, the fan cover of the device is prone to blockage by air particles. Regularly disassemble and clean the fan to prevent reduced internal air flow in the inverter, which may trigger over-temperature protection faults (Fault 19/20), affecting power supply usage and the inverter's service life.

4. Connection Instructions

4.1 Single-phase Mode

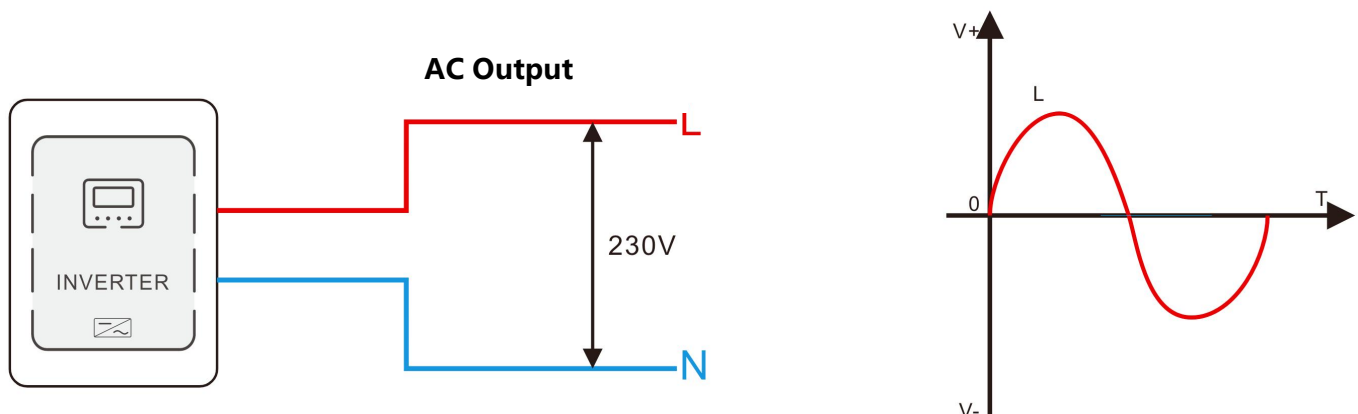

Project	Description
Applicable model	AEP4860S135-H model
AC Output Voltage Range (L-N)	200~240Vac, 230Vac default

Single-phase Mode

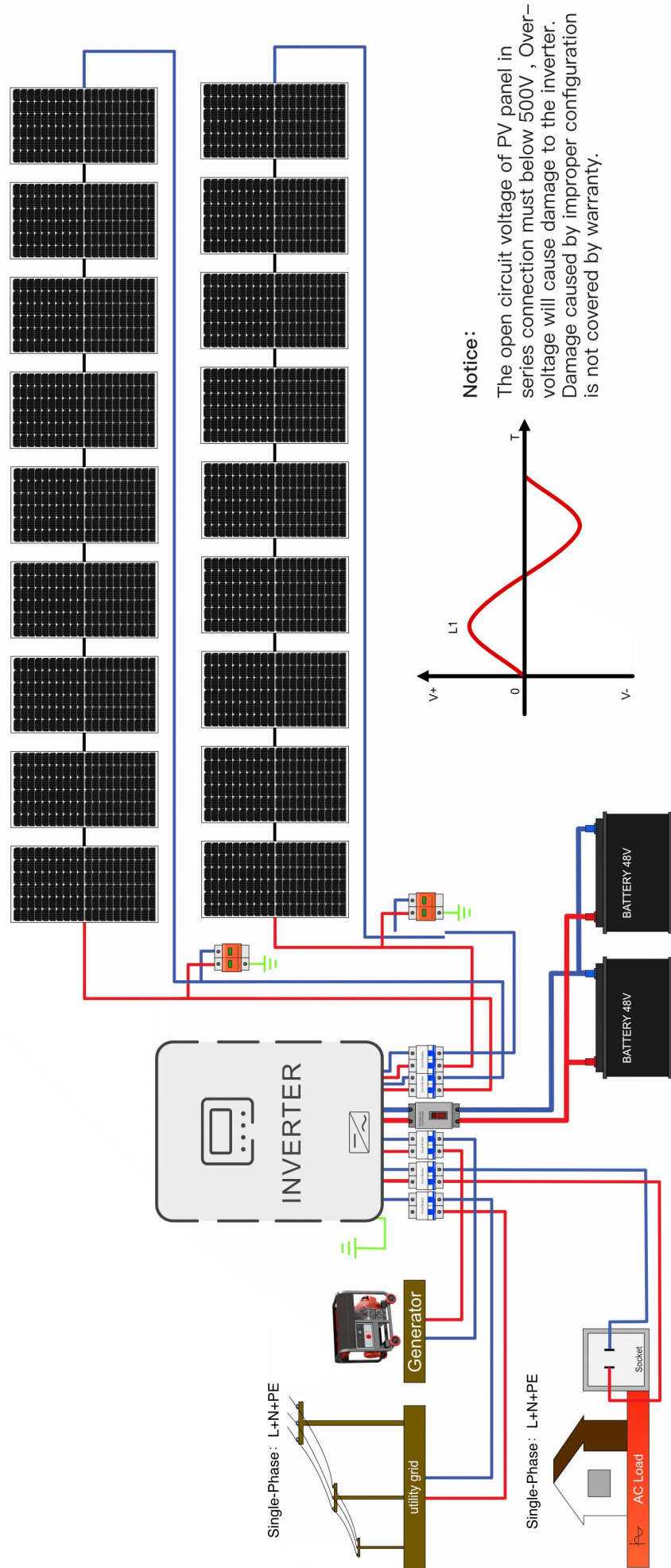

4.2 Cable & Circuit Breaker Requirement

■ PV Input

Models	Circuit Count	Cable Diameter	Max. Input Current	Circuit Breaker Spec
AEP4860S135-H	PV1	10AWG/6mm ²	22A	2P-25A
	PV2	10AWG/6mm ²	22A	

■ Battery

Models	Cable Diameter	Max. Input Current	Circuit Breaker Spec
AEP4860S135-H	1AWG/43mm ²	135A	2P-200A

■ Grid

Models	Cable Diameter	Max. Input Current	Circuit Breaker Spec
AEP4860S135-H	8AWG/10mm ²	40A	2P-40A

■ Generator

Models	Cable Diameter	Max. Input Current	Circuit Breaker Spec
AEP4860S135-H	8AWG/10mm ²	40A	2P-40A

■ Load

Models	Cable Diameter	Max. Input Current	Circuit Breaker Spec
AEP4860S135-H	8AWG/10mm ²	40A	2P-40A

⚠ NOTICE

● AC input and AC output:

1. Use a wire stripper to remove 6-8mm of insulation from the cable.
2. Fix a cable gland at the end of the cable (the cable gland should be prepared by the user).

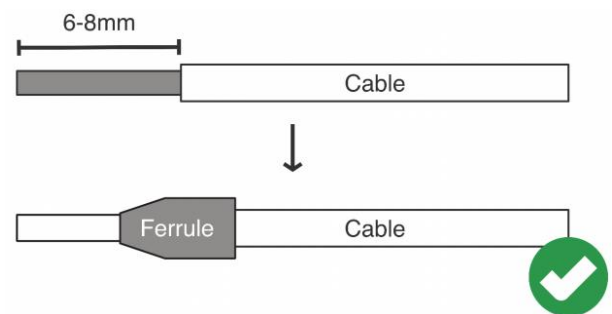

● Battery:

1. Use a wire stripper to remove 6-8mm of insulation from the cable.
2. Fix the cable lug provided with the package at the cable end.

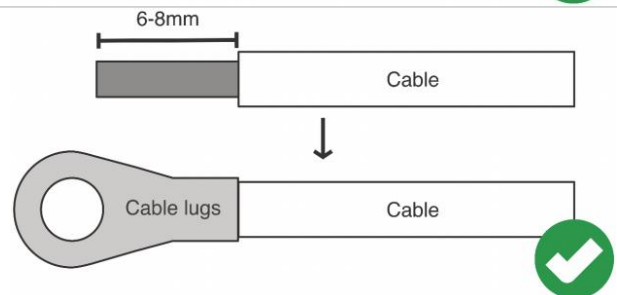

The wire diameter is for reference only. If the distance between the PV array and the inverter or between the inverter and the battery is long, using a thicker wire will reduce the voltage drop and improve the performance of the system.

4.3 GRID & LOAD & Generator Connection

Connect the live, neutral and ground wires according to the cables' position and order shown in the diagram below.

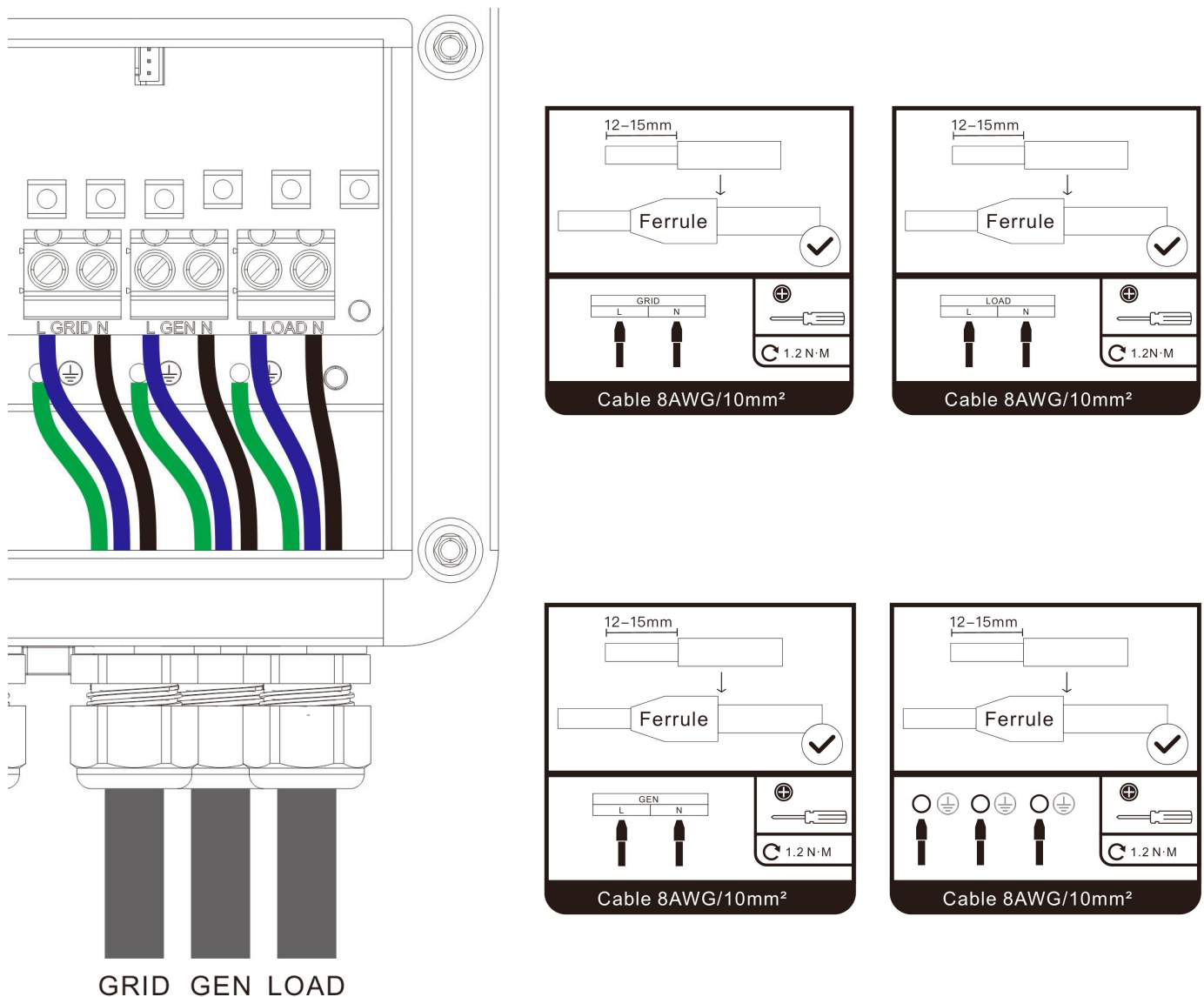

DANGER

- Before connecting AC input and output, the circuit breaker must be turned off to avoid electric shock hazards, and never operate with electricity.
- Please check that the cable used is sufficient for the requirements, too thin, poor quality cables are a serious safety hazard.

4.4 Battery Connection

Connect the positive and negative cable of the battery according to the diagram below.

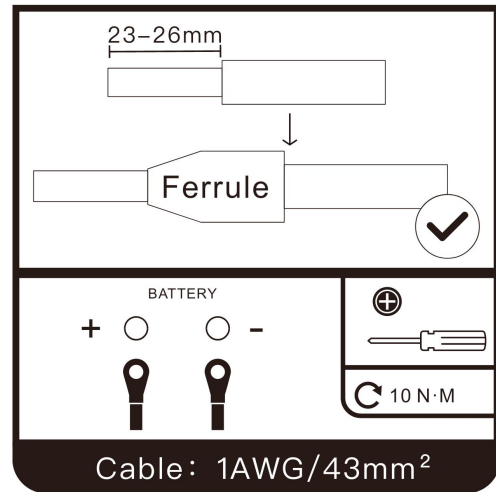
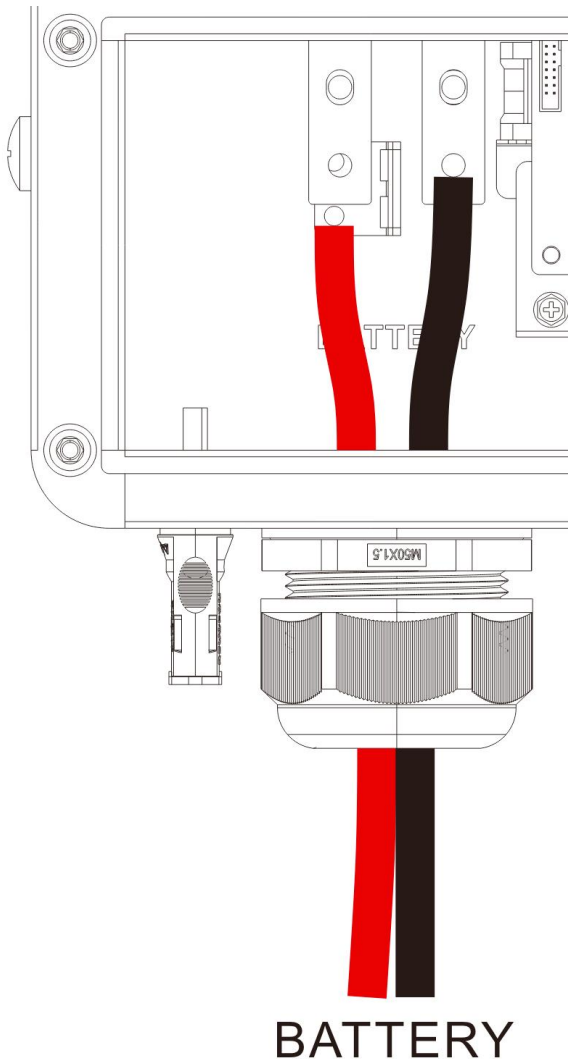

⚠ DANGER

- Before connecting battery, the circuit breaker must be turned off to avoid electric shock hazards, and never operate with electricity.
- Make sure that the positive and negative terminals of the battery are connected correctly, reversed polarity connection on battery will damage the inverter.
- Please check that the cable used is sufficient for the requirements, too thin, poor quality cables are a serious safety hazard.

4.5 PV Connection

1. Before connecting PV, first close the external circuit breaker and make sure that the cable used is sufficiently thick. Please refer to section "4.2 Cable & Circuit Breaker Selection".

2. According to the cable sequence and terminal positions shown in the figure below, correctly connect the PV input wires. When using in parallel, different units must be connected to different PV arrays or PV sources.

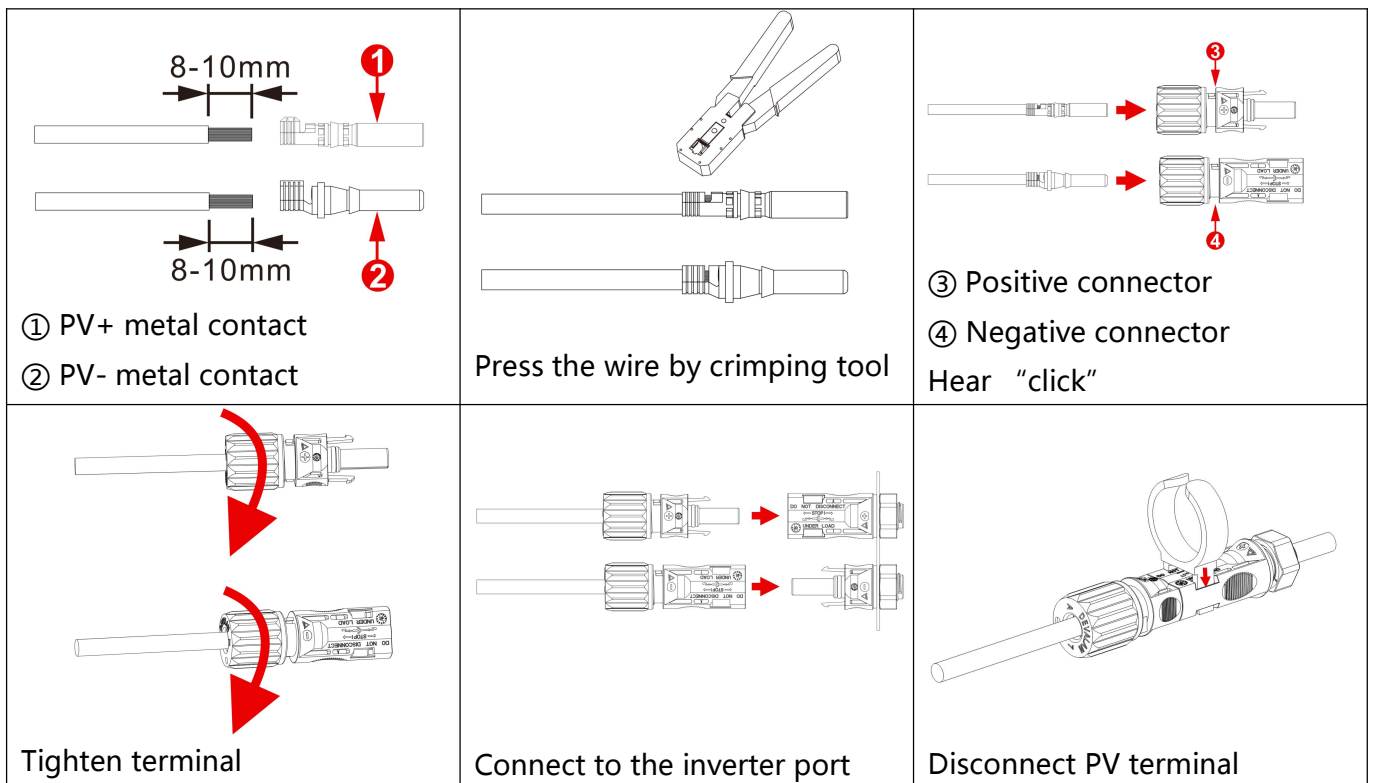
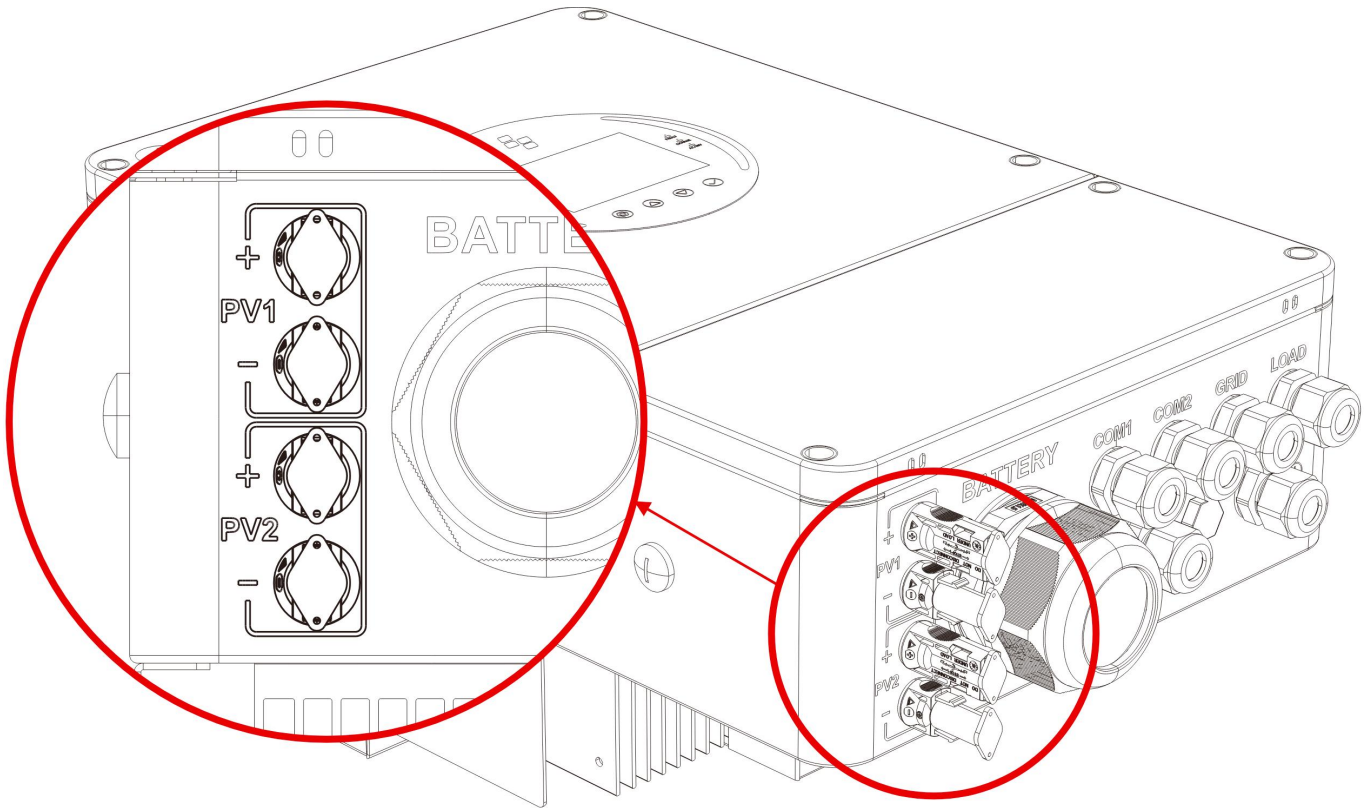

⚠ DANGER

- Before connecting the PV, the circuit breaker must be turned off to avoid electric shock hazards, and never operate with electricity.
- Make sure that the open-circuit voltage of the PV modules connected in series does not exceed the maximum open-circuit voltage of the inverter (the value is 600V), otherwise the inverter may be damaged.

Transmitter-PLC Device(Customer Optional)

The inverter includes a rapid shutdown system that complies with 2017 and 2020 NEC 690.12 requirements. A rapid shutdown switch should be connected to the RSD terminals on the inverter and mounted on a readily accessible location outdoors (check with your AHJ for requirements).

The APsmart Rapid Shutdown System Transmitter-PLC is part of a rapid shutdown solution when paired with APsmart RSD, a PV module rapid shutdown unit. While powered on, the Transmitter-PLC sends a signal to the RSD units to keep their PV modules connected and supplying energy. RSD units automatically enter rapid shutdown mode when the Transmitter-PLC is switched off and resume energy production when power is restored to the Transmitter-PLC.

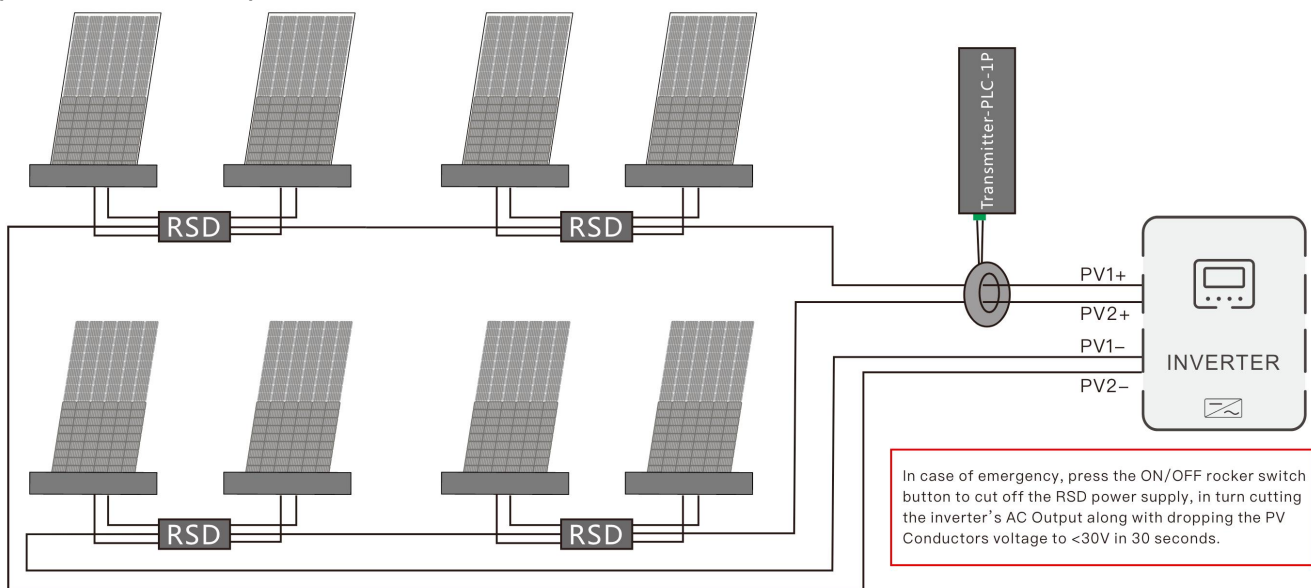

4.6 Dry Contact Connection

Use a small screwdriver to push back the direction indicated by the arrow, then insert the communication cable into the dry junction port.

(Communication cable diameter 0.2~1.5mm²)

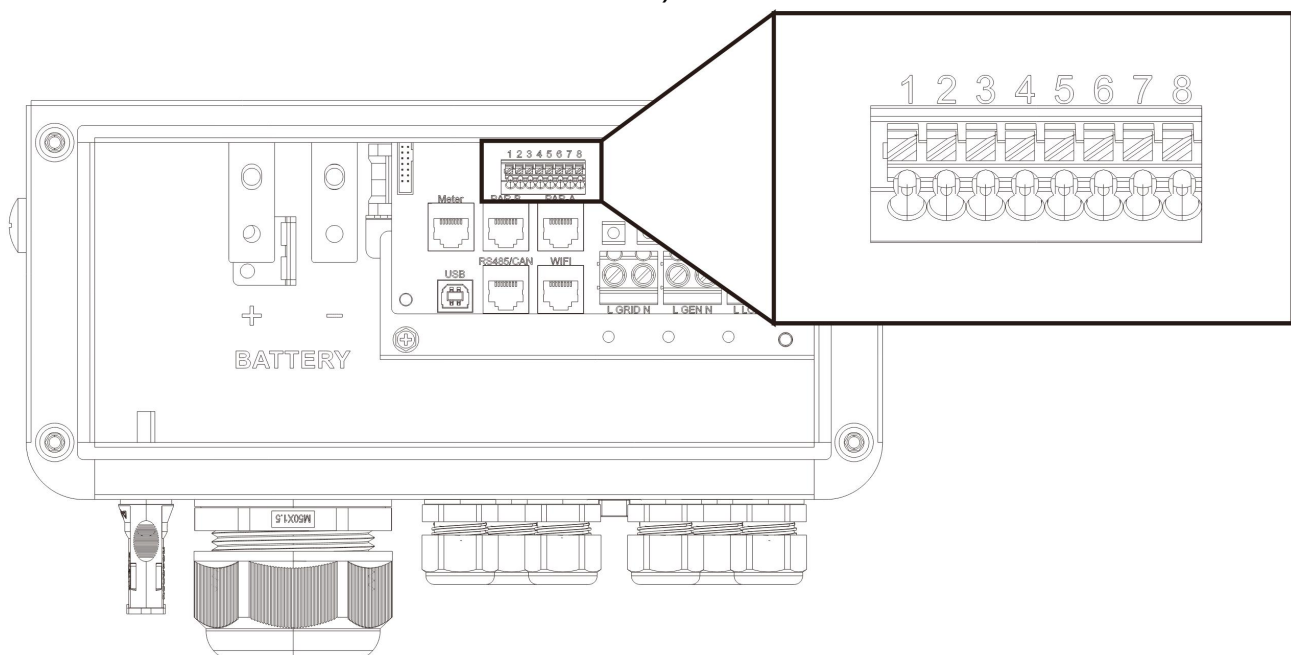

4.7 Grounding Connection

Please make sure the grounding terminal connect to the Grounding Bar.

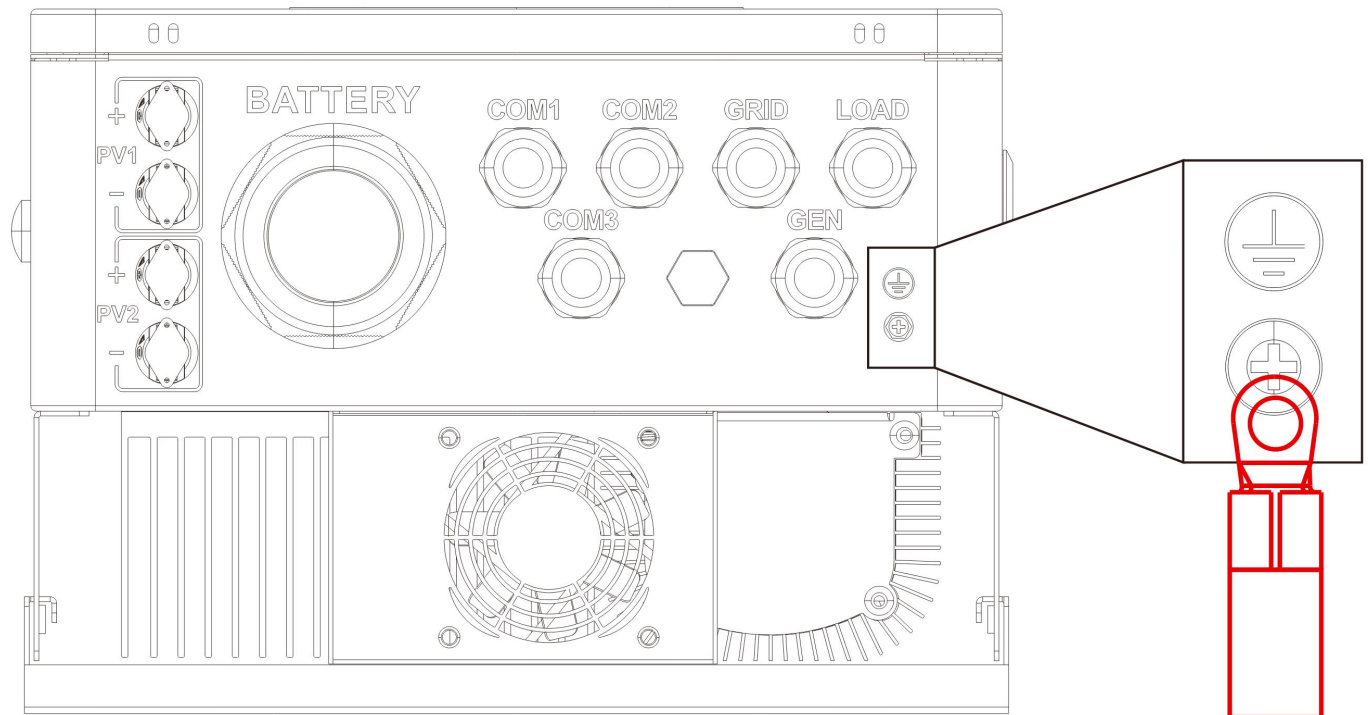

NOTICE

The grounding cable should have a diameter of not less than 4 mm² and be as close as possible to the grounding point.

4.8 Final Installation

After ensuring that the wiring is reliable and the wire sequence is correct, install the terminal protection cover in place.

- **Step 1:** Close the circuit breaker of the battery.
- **Step 2:** Press the ON/OFF switch on the side of the inverter. The screen and indicator lights turning on indicates that the inverter has been activated.
- **Step 3:** Sequential close of the circuit breakers for PV, AC input and AC output.
- **Step 4:** Start the loads one by one in order of power from small to large.

4.9 Parallel Connection

4.9.1 Introduction to Parallel Connection

1. Up to six units connected in parallel.
2. When using the parallel operation function, the following connecting lines (package accessories) shall be firmly and reliably connected.

3. For a single inverter, press DIP 1 and DIP 2.

When inverters are paralleled, press DIP 1 and DIP 2 on the first and last inverters.

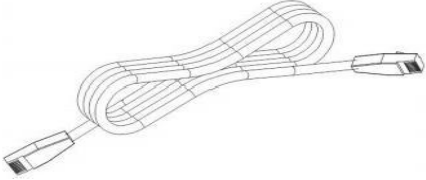
DIP Switch	Parallel communication line*1
	

4.9.2 Precautions for Connecting the Parallel Connecting Lines

Warning

1.PV connection:

When connecting in parallel, the PV arrays connected to each inverter must be independent of each other. The PV arrays corresponding to PV1, PV2 ports of the same inverter must also be independent.

2.Battery connection:

For split-phase or three-phase parallel operations, all solar energy storage inverters must be connected to the same battery bank. Connect BAT+ to BAT+ and BAT- to BAT-. Before powering on the system, thoroughly check the wiring configuration to ensure correctness. Confirm that the wiring lengths between each inverter and the battery are consistent, and verify that the cable size meets the system's current transmission requirements. Incorrect connections may cause abnormal operation of the parallel system.

3.Load connection:

For split-phase parallel connection: all solar storage inverters must be connected in the manner of L-to-L, N-to-N, and PE-to-PE, and before power on and start-up, it is necessary to check and ensure correct connection, wiring length, and cable size, so as to avoid the abnormal operation of parallel system output caused by wrong connection.

For three-phase parallel connection: all solar storage inverters must be connected in the manner of N-to-N and PE-to-PE. The L lines of all inverters in the same phase shall be connected together, but the AC output L lines of different phases shall not be connected together. Other cautions are the same as those for split-phase parallel connection. Refer to the schematic diagram for wiring.

4. Grid connection:

In split-phase parallel connection, all solar storage inverters must be connected in the manner of L-to-L, N-to-N, and PE-to-PE, and before power on and start-up, it is necessary to check and ensure correct connection, wiring length, and cable size, so as to avoid the abnormal operation of parallel system output caused by wrong connection.

Meanwhile, it is not allowed to have multiple different AC source inputs to avoid damage to the external equipment of the inverter. The AC source input shall be consistent and unique. Refer to Chapter 4.9.3 for wiring diagrams for parallel connection.

In three-phase parallel connection, all solar storage inverters must be connected in the manner of N-to-N and PE-to-PE. The L lines of all inverters in the same phase shall be connected together, but the AC output L lines of different phases shall not be connected together. Refer to the schematic diagram for wiring.

5. Communication Lines:

Our parallel communication cable is a shielded 8-pin network cable suitable for both split-phase and three-phase parallel connections. Each unit must have one input and one output connection.

In a parallel system, the "Parallel A" interface of this machine must be connected to the "Parallel B" interface of the target machine. It is strictly prohibited to connect the "Parallel A" interface of this machine to either the "Parallel B" interface of the same machine or the "Parallel A" interface of the target machine.

Additionally, secure each unit's parallel communication cable firmly to the 8-pin network connector to prevent disconnections or poor contacts, which may lead to abnormal system operation or damage to the output.

6. Before and after connecting the system, carefully refer to the system wiring diagram below. Ensure all connections are correct and secure before powering on.

7. After the system is correctly wired, powered on, and operating normally, if a new inverter needs to be connected, ensure that the battery input, PV input, AC input, and AC output are disconnected, and all solar energy storage inverters are powered off before reconnecting to the system.

4.9.3 Schematic Diagram for Single-Phase Parallel Connection

In case of parallel operation with multiple inverters, the schematic diagram of parallel connection is as follows:

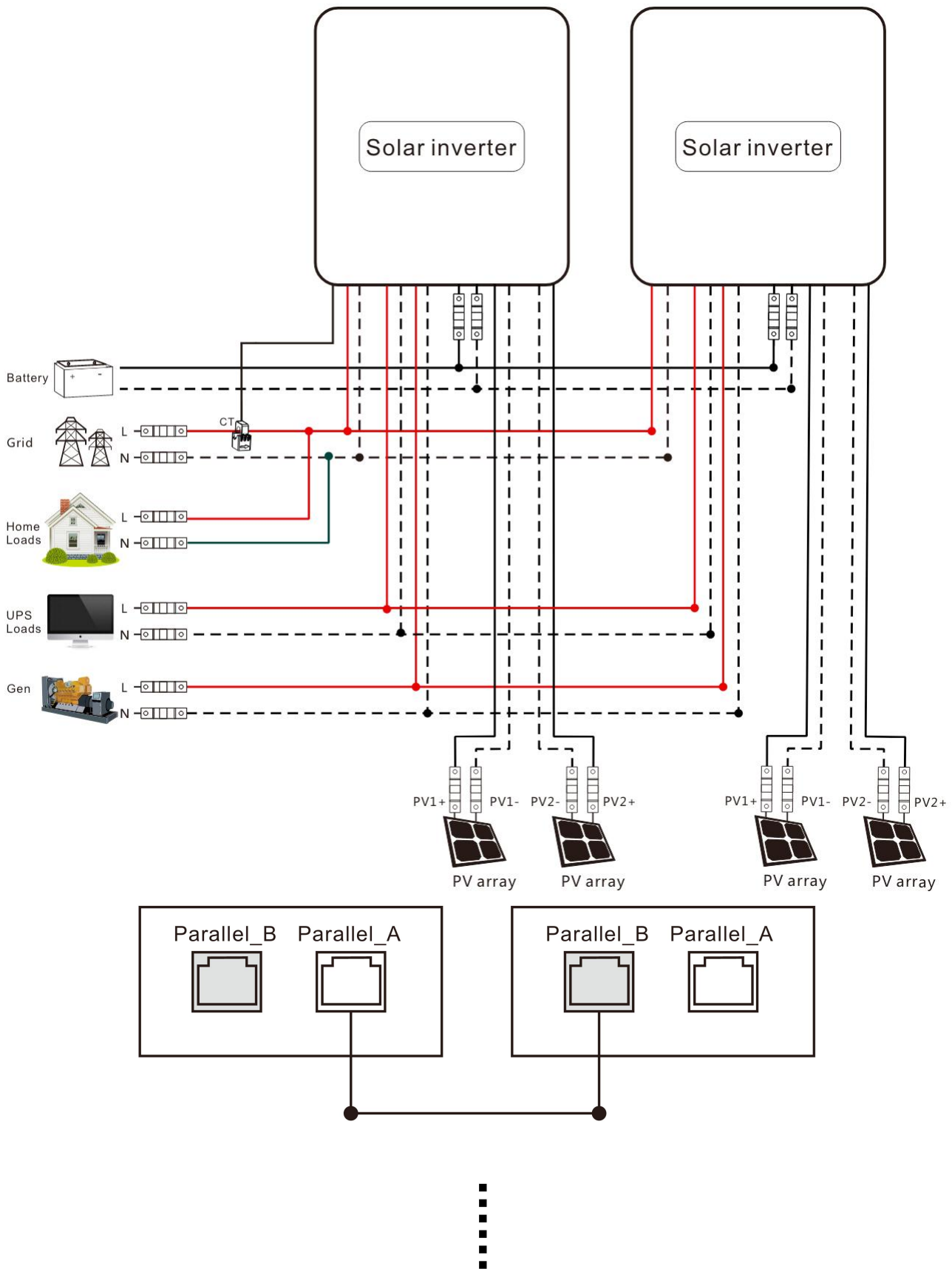

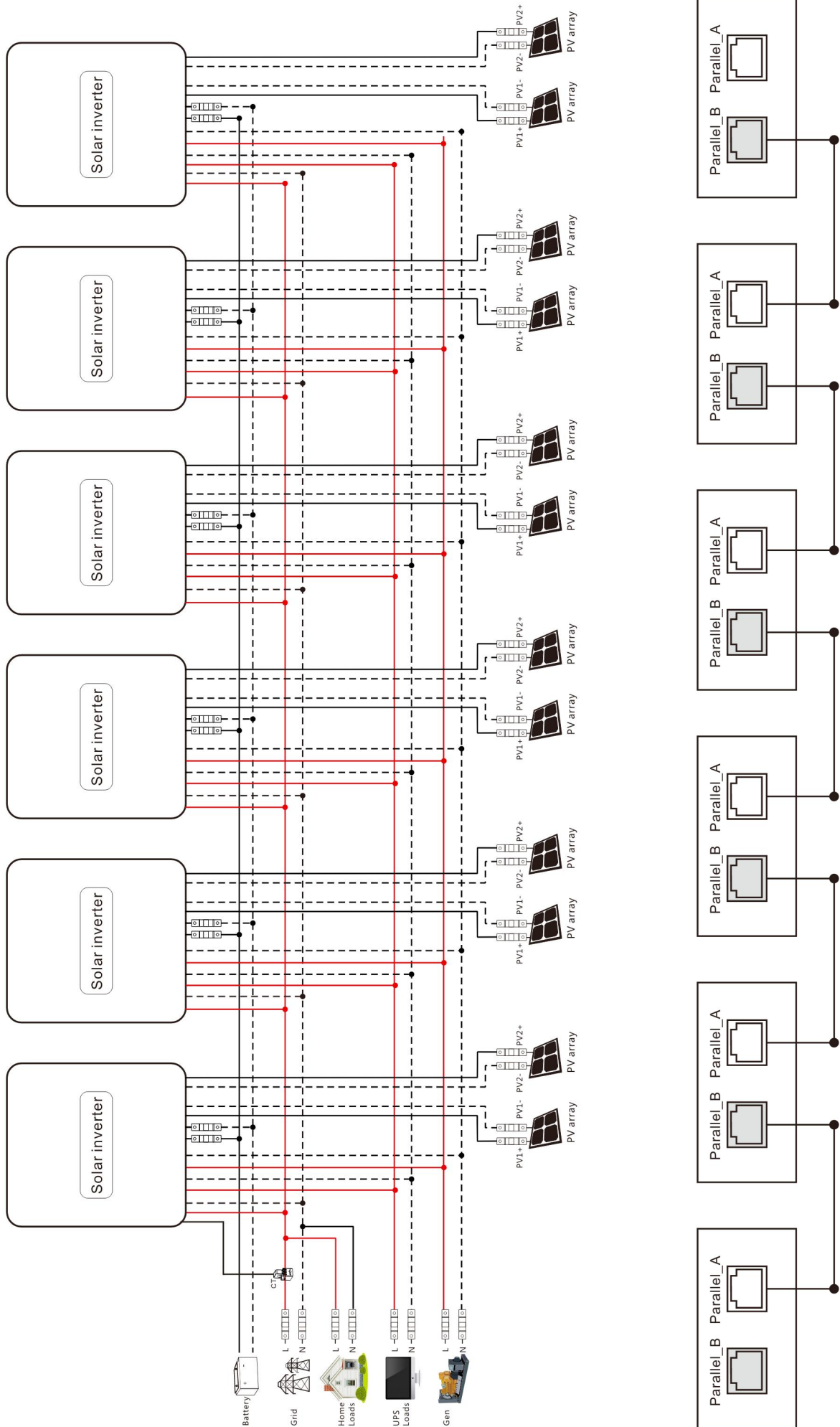

4.9.4 Schematic Diagram for Three-Phase Parallel Connection

Ensure the parallel communication cables of the solar energy storage inverters are securely clamped with no loose connections.

When multiple inverters operate in parallel, refer to the following schematic diagram:

Parallel Operation in three phase :

Three all-in-one solar storage inverters of the system connected in three phase:

1+1+1 system:

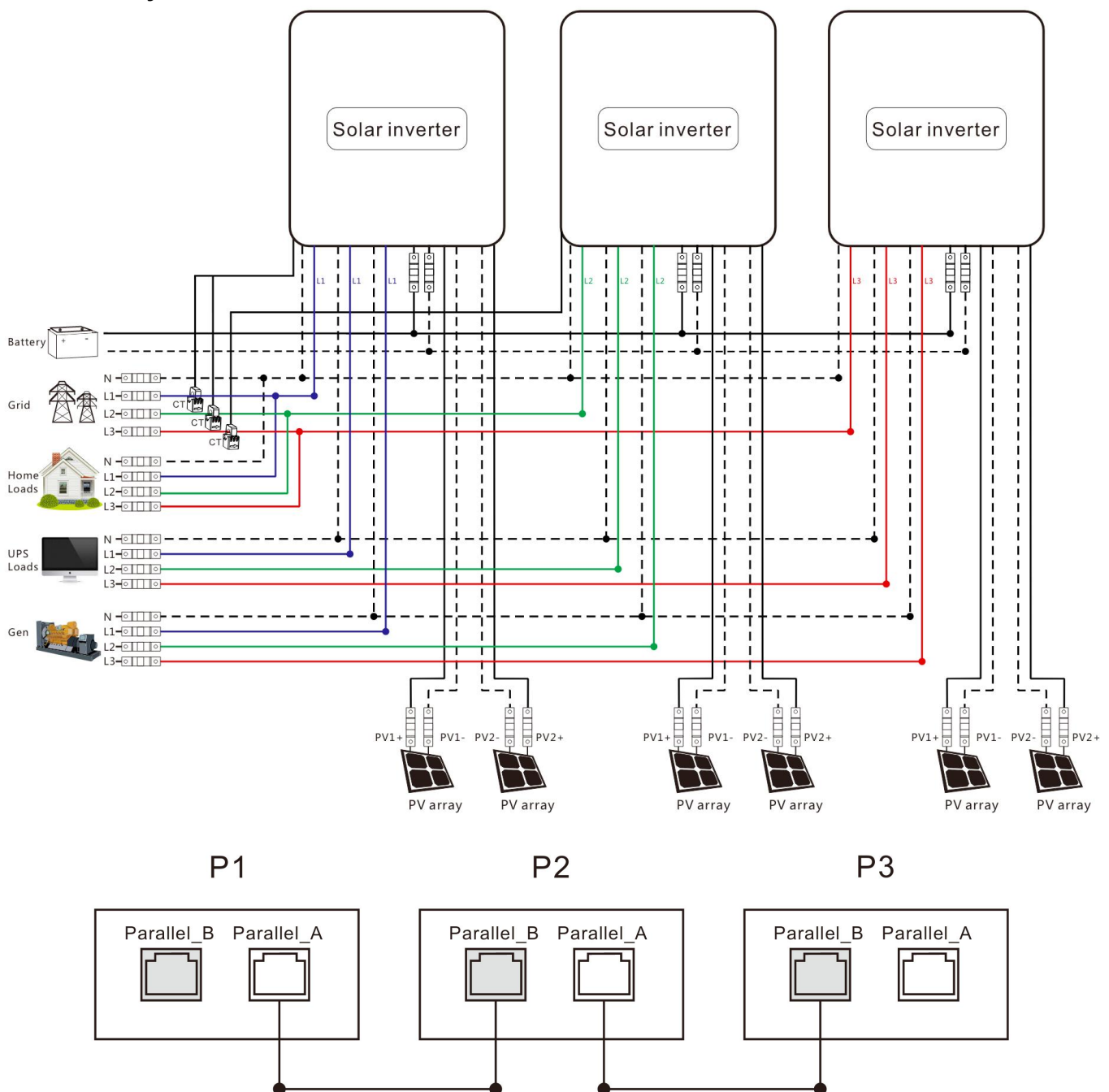

Six all-in-one solar storage inverters of the system connected in three phase:

2+2+2 system:

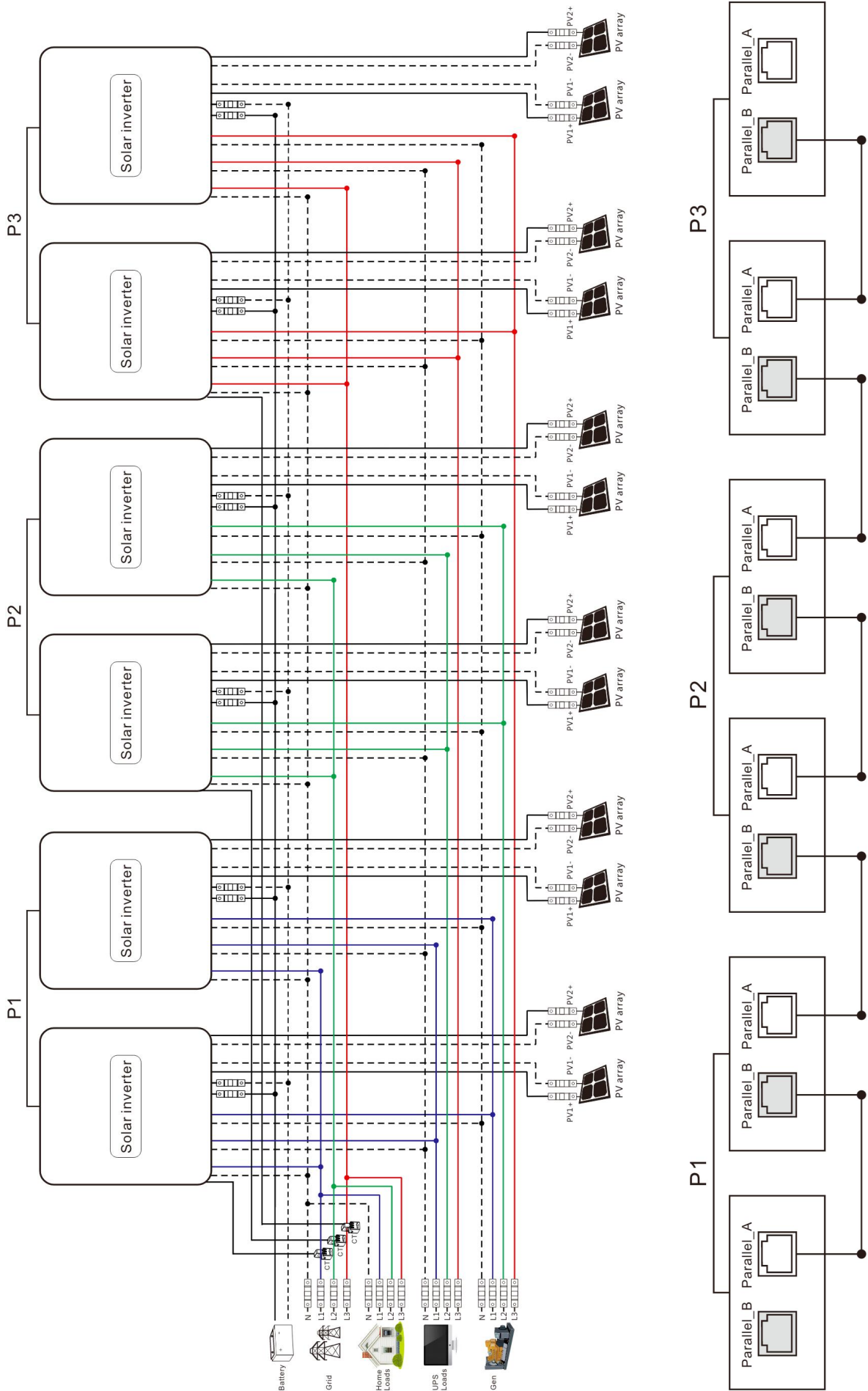

Notice:

- 1) Before starting up and running, please check whether the connection was correct to avoid any abnormalities in the system.
- 2) All wiring must be fixed and reliable to avoid wire drop during use.
- 3) When the AC output is wired to the load, it shall be properly wired according to the requirements of the electrical load equipment to avoid damage to the load equipment.
- 4) Settings [38] need to be set consistently or only for the host. When the machine is running, the voltage set by the host shall prevail, and the master will force the rewrite of the other slave machines to keep the same set. Only can be set in the standby mode.
- 5) Machine factory default for single machine mode, if you use parallel, split-phase or three-phase function, you need to set the [31] item parameters through the screen. The setting method is: power on one machine at a time, the rest of the machine off, and then set the [31] item parameters according to the site system operation mode. After this machine is set successfully, turn off the machine switch and wait for the machine to be powered down, then set the rest of the machines in turn until all machines are set, and then all machines are powered up again at the same time and enter the working state.
- 6) The [31] setting item :
When in single phase parallel connection : setting 【31】 should be set as 【PAL】
When in single phase parallel connection, setting 【31】 should be set as follows :
When in three phase parallel connection ,all machines in phase 1 must be set as “3P1” , all machines in phase 2 must be set as “3P2” all machines in phase 3 must be set as “3P3” , at present, the voltage phase difference between P1-P2, P1-P3 and P2-P3 is 120 degrees.
When the output voltage set in the setting 【38】 is 230Vac (S model), the line voltage between the live wire L1 in phase 1 and the live wire L2 in phase 2 is $230 \times 1.732 = 398\text{Vac}$, and similarly the line voltage between L1-L3, L2-L3 is 398Vac; the single phase voltage between L1-N, L2-N, L3-N is 230Vac.
- 7) After the system runs, the output voltage is measured correctly, and then the load setting is connected.



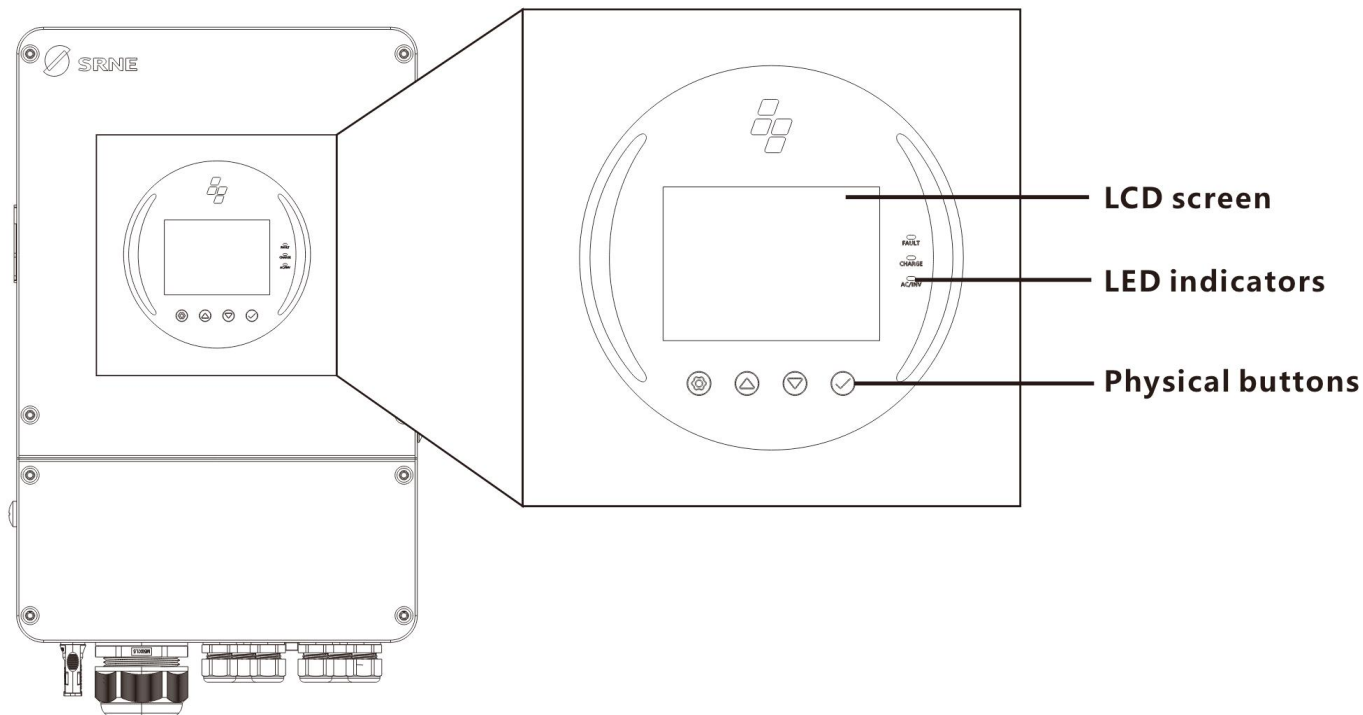

5. Operation

5.1 Operation and Display Panel

The operation and display panel below includes 1 LCD screen, 3 LED indicators, and 4 physical buttons.



■ Physical buttons

Button	Description
	To enter/exit settings menu
	To go to previous selection
	To go to next selection
	To confirm/enter selection in settings menu







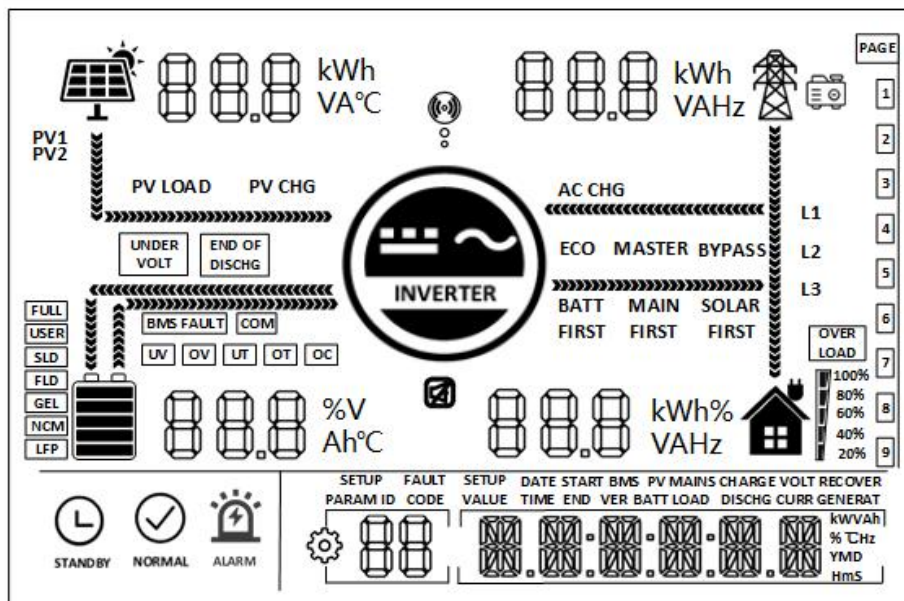









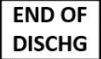

■ LED indicators

Indicator	Color	Description
AC/INV	Yellow	Always on: utility grid output
		Flashing: inverter output
CHARGE	Green	Always on: charging completed
		Flashing: charging in progress
FAULT	Red	Always on: Error occurred



■ LCD screen

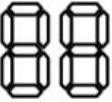
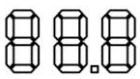

Icon	Function	Icon	Function
	Indicates mains power		Indicates the inverter is working
	Indicates generator		Indicates home appliances
	Indicates solar power		Indicates AC output is overload
	<ul style="list-style-type: none"> Battery remaining capacity is below 5% Battery remaining capacity is 5%~19% Battery remaining capacity is 20%~39% Battery remaining capacity is 40%~59% Battery remaining capacity is 60%~79% Battery remaining capacity is 80%~100% 		<ul style="list-style-type: none"> Load percentage is below 5% Load percentage is 5%~19% Load percentage is 20%~39% Load percentage is 40%~59% Load percentage is 60%~79% Load percentage is 80% ~ 100%
	Indicates that the machine is communicating with the Surveillance Equipment		Indicates that the buzzer is not enabled
	Indicates that the battery is fully charged		Indicates that the current battery type of the machine is user-defined
	Indicates that the current battery type of the machine is sealed lead-acid battery		Indicates that the current battery type of the machine is flooded lead-acid battery
	Indicates that the current battery type of the machine is gel battery		Indicates that the current battery type of the machine is NCM battery







	Indicates that the current battery type of the machine is LFP battery		Display the page number prompt of the main interface
			Indicates the data page of the main display interface
	Indicates that the machine is currently idle		Indicates that the machine is currently in normal operation
	Indicates that the machine is currently in an alarm or fault state		Indicates that the machine is currently in the parameter setting state
PV LOAD	Indicates that the PV is in a direct load state	PV CHG	Indicates that the PV is in a state of charge
AC CHG	Indicates that the AC is in a state of charge	BYPASS	Indicate that the Mains Power is in the bypass state
ECO	Indicates that the system is enabled in the ECO mode	BATT FIRST	Indicates that the output mode is Battery First
MASTER	Master Unit Identification in Parallel Operation Mode.	MAIN FIRST	Indicates that the output mode is Mains Power first
SOLAR FIRST	The indicated output mode is Solar First.		Indicates battery under voltage
	Battery over-discharge		Indicates internal communication failure
	Indicates system under voltage		Indicates system over voltage
	Indicates system low temperature		Indicates system over temperature
	Indicates system over current		Indicates BMS communication failure
	Indicates the direction of energy flow		
	When the system is in alarm or fault state, the main interface displays fault code; display setting options when setting		Display parameters of PV, battery, mains power and load
SETUP DATE START BMS PV MAINS CHARGE VOLT RECOVER VALUE TIME END VER BATT LOAD DISCHG CURR GENERAT  kWVAh %°C Hz YMD HmS	Main Interface: display real-time time, date, total PV power generation, total load power consumption, RS485 address, version number Setting Interface: display setting contents		

■ Real-time data viewing method

On the LCD main screen, press   the button for page turning to view the real-time data of the machine.

Page	PV side parameters	Battery side parameters	Mains side parameters	Load side parameters	Comprehensive parameters
1	PV Voltage	Batt Voltage	AC Voltage	Load Voltage	Current Time
2	PV Current	Batt Current	AC Current	Load Current	Current Date
3	PV Power	Battery power	AC Power	LoadPower	PV Total kWh
4	PV Today kWh	BMS Batt SOC	Smart Meter Power	LoadToday kWh	LoadTotal kWh
5	PV Temperature	BMS Volt	AC Frequency	Load Frequency	RS485 Address
6	Bus Voltage	INV Temperature	Today on grid power	Load kVA	Soft Version
7	PV Rated Voltage	Batt Rated Current	Reserved	Load Rated Power	Parallel Mode
8	Reserved	Reserved	Reserved	Reserved	Customer ID
9	Reserved	Reserved	Reserved	Reserved	From chip version

5.2 Setting Parameters

Key Operation Instructions: Enter the setting menu and exit the setting menu, please press  , After entering the setting menu, the parameter number [00] will flash. At this time, you can press the  and  key to select the parameter code to be set. Then press  to enter the parameter editing state, at this time, the value of the parameter flashes, adjust the value of the parameter through the  and  , and finally press  to complete the editing of the parameter and return to the parameter selection state.

The voltage setting logic: 【15】 < 【12】 < 【04/14】 < 【35】 < 【37】 < 【05】 < 【09/11】

Parameter Number	Parameter Name	Setting Options	Description
00	Exit	[00] ESC	Menu of Exit Settings
01	Supply Priority Mode	[01] UTI	PV energy priority with the load, When PV power is insufficient, the grid and PV jointly supply the load. When PV power exceeds the load demand, the surplus charges the battery. Grid charging is activated only when the battery is over-discharged. (06 Settings as "OSO(only PV)", the grid power will not charge), the battery is only discharged when off the grid.

		[01] SBU	Prioritises the use of PV to power the load and switches back to the grid to power the load only when the battery voltage is lower than the set value in parameter item [4] (when connected to the BMS, according to item [61]). When the battery voltage is higher than the value set in parameter [5] (when connected to the BMS, according to item [62]), it switches back to the PV from the grid to supply the load.
		[01] SUB default	PV energy first used for charging, the remaining energy supply load, when PV energy is insufficient, it is supplemented by the grid, the grid energy is first supplied to the load and second used for charging (if 06 Settings as "OSO(only PV)", the grid energy will not be used for charging).
		[01] SOL	PV first mode. When the PV power is unavailable or the battery voltage is lower than the set value in the item 4, it will switch to the grid mode
02	Output Frequency	[02] 50.0 Default	Bypass self-adaptation; when the mains is connected, it automatically adapts to the mains frequency; when the mains is disconnected, the output frequency can be set through this menu.
		[02] 60.0	
03	AC input voltage range	[03] UPS Default	When output voltage is 220/230V, input voltage range: 170V~280V, UPS frequency range: 50Hz frequency class 47-55Hz, 60Hz frequency class 57-65Hz
		[03] APL	When output voltage is 220/230V, input voltage range: 90V~280V, APL frequency range: 40-70Hz
04	Battery to grid	[04] 46V Default	When parameter [01]=SBU/SOL , output source will switch to grid from battery when the battery voltage below the preset value. Setting range: 40V ~ 57.2V.
05	Mains to battery	[05] 57.6V Default	When parameter [01]=SBU/SOL , output source will switch to battery from grid when the battery voltage above the preset value. Setting range: 48V ~ 60V.
06	Charging mode	[06] SNU default	PV and grid hybrid charging, with PV charging prioritized. When PV energy is insufficient, mains charging supplements it. When PV energy is sufficient, mains charging stops. Note: PV and mains can only charge simultaneously when the mains bypass output is loaded. During inverter operation, only PV charging can be activated.
		[06] OSO	Only PV charging, without activating grid charging.
07	Max. charging current	[07] 100A Default	Setting range: 0~135A
08	Battery type	[08] USER	User-defined, user can set all battery parameter.
		[08] SLd	Sealed lead-acid battery.

		[08] FLd	Flooded lead-acid battery.
		[08] GEL	Gel lead-acid battery.
		[08] L14/ L15 / L16 Default	L14/ L15/ L16 lithium iron phosphate batteries, corresponding to lithium iron phosphate batteries 14, 15, 16 series.
		[08] N13/ N14	Ternary lithium batteries, N13/N14, corresponding to ternary lithium batteries 13 series, 14 series.
		[08] No battery	No battery.
09	Boost Voltage	[09] 56.8V Default	Setting of Boost Voltage: Set Range of 48V~58.4V, Step 0.4V, available when the battery type is user-defined and lithium battery.
10	Boost charging max. time	[10] 120 Default	Maximum Boost Charging Duration Setting: It refers to the maximum charging time when the voltage reaches Parameter [09] during constant voltage charging. The setting ranges from 5 minutes to 900 minutes with a step of 5 minutes.
11	Float charging voltage	[11] 56.8V Default	Floating Charge Voltage, with the Set Range of 48V~58.4 V, Step of 0.4 V.
12	Over-discharge voltage	[12] 48.8V Default	Over-discharge Voltage: The battery voltage is lower than such criterion, and the Inverter output is turned off after the time delay parameter is set to [13] , with the Set Range of 40V~52V and Step of 0.4V.
13	Over discharge delay Time	[13] 30S Default	Over-discharge Delay Time: when the battery voltage is lower than the Parameter [12] , the inverter output is turned off upon delay of time set by this Parameter, with the Set Range of 5S~50S, Step of 5S.
14	Battery under voltage alarm point	[14] 49.6V Default	Battery under-voltage alarm point: when the battery voltage is lower than such criterion, under-voltage alarm will be given, the output will not be shut down, with the Set Range of 40V~52.8V, Step of 0.4V.
15	Battery discharge limit voltage	[15] 46.4V Default	Battery Discharge Limit Voltage: the battery voltage is lower than such criterion, output and shut down immediately. Set Range of 40V~52V, Step of 0.4V, available when the battery type is user-defined and lithium battery.
16	Equalization charging	[16] dIS	No equalization charging.
		[16] ENA Default	Enable equalization charging, only Flooded lead-acid batteries, sealed lead-acid batteries and user-defined are effective.
17	Equalization charging voltage	[17] 58V Default	Equalization Charging Voltage, with the Set Range of 48V~58.4V, Step of 0.4V, available for Flooded lead-acid battery, sealed lead-acid battery and user-defined.
18	Equalization charging time	[18] 120 Default	Equalization Charging Time, with the Set Range of min~900min, Step of 5min, available for Flooded lead-acid battery, sealed lead-acid battery and user-defined.

19	Equalized charging delay	[19] 120 Default	Equalization Charging Delay, with the Set Range of min~900min, Step of 5min, available for Flooded lead-acid battery, sealed lead-acid battery and user-defined
20	Equalization Charge interval time	[20] 30 Default	Equalization Charge Interval Time, 0~30 days, Step of 1d, available for Flooded lead-acid battery, sealed lead-acid battery and user-defined.
21	Equalization charging start-stop	[21] ENA	Start equalization charging immediately
		[21] dIS Default	Stop equalization charging immediately
22	Energy-saving mode	[22] dIS Default	Power saving mode disabled.
		[22] ENA	After the power saving mode is enabled, if the load is null or less than 25W, the inverter output is turned off after a delay for a certain period of time. When the load is more than 25W, the inverter automatic restart. Note: Only valid when the battery is discharging.
23	Overload Automatic Restart	[23] dIS	Overload automatic restart is disabled. If overload occurs, the output will be shut down, and the machine will not be restarted.
		[23] ENA Default	Enable overload auto restart. If overload occurs, shut down output, delay the machine for 3 min and then restart the output. After 5 times in total, no startup will be resumed.
24	Auto restart upon over-temperature	[24] dIS	Over-temperature automatic restart is disabled. If over-temperature occurs, the output will be shut down, and the machine will not be restarted for output.
		[24] ENA Default	Enable automatic restart upon over-temperature. If over-temperature occurs, shut down output, and restart output after the temperature has dropped.
25	Buzzer Alarm	[25] dIS	No Alarm
		[25] ENA Default	Enable alarm
26	Mode Change Reminder	[26] dIS	Alarm is disabled when the status of the main input source has change.
		[26] ENA Default	Alarm is disabled when the status of the main input source has change.
27	Inverter Overload to Bypass	[27] dIS	Automatic switch to Mains Power is disabled when the Inverter is overloaded.
		[27] ENA Default	Automatic switch to Mains Power when the inverter is overloaded.
28	Current of charging under grid electricity	[28] 100A Default	Set range: 0~135A.
29	BMS communication error stopped	[29] dIS Default	When a BMS communication error occurs, the inverter stops output.

30	RS485 Address Setting	[30] 1 Default	Single-machine setting range: 1~254 Parallel-machine setting range: 1~6
31	AC output mode (can be set in the standby mode only)	[31] SIG Default	Single machine setting.
		[31] PAL	Single-phase parallel connection setting.
		[31] 3P1/3P2/3P3	Three-phase parallel connection setting.
		All machines in phase 1 must be set as 【3P1】 All machines in phase 2 must be set as 【3P2】 All machines in phase 3 must be set as 【3P3】 When the output voltage set in the setting 【38】 is 230Vac (S model) At this time, the voltage phases between (P1-P2, P1-P3, P2-P3) differ by 120 degrees. The voltage between the live wire L1 of phase P1 and the live wire L2 of phase P2 is $230 \times 1.732 = 398\text{Vac}$. Similarly, the line voltage between L1-L3 and L2-L3 is 398Vac; the voltage between L1-N, L2-N, and L3-N is 230Vac.	
32	Communication function	[32] dIS Default	Disable BMS communication.
		[32] 485	485-BMS communication.
		[32] CAN	CAN-BMS communication.
33	BMS communication protocol	When item [32] = 485 / CAN , the corresponding lithium battery manufacturer brand should be selected for communication.	
		WOW default	485 protocol: PAC=PACE ; RDA=Ritar ; AOG=ALLGRAND BATTERY ; OLT=OLITER ; CEF=CFGE ; XWD=SUNWODA ; DAQ=DYNESS ; WOW=SRNE ; PYL=PYLONTECH ; VOL=WEILAN ; SGP=SGP ; GSL=GSL energy ; PYT=Pylon tech 2 CAN protocol: UZE=UZENERGY ; SGP=SGP ; GSL=GSL energy ; PYT=Pylon tech 2
34	ON-GRID function	[34] dIS Default	Disable this Function.
		[34] ON GRd	When parameter [01]=UTI , PV energy will be prioritized for load supply. After meeting the load demand, the remaining electricity will be fed back to the grid, and any further excess energy will be used to charge the battery. When parameter [01]=SUB , PV energy will prioritize charging the battery. After meeting the battery demand, the remaining electricity will be used to power the load (if the remaining electricity is insufficient for the load, the remaining PV power will be mixed with grid power to supply the load), and any additional excess energy will be fed back to the grid.

		[34] HOM LOD	<p>When parameter [01]=UTI, PV energy will be prioritized for load supply. Excess energy will be subject to anti-backflow control, and any remaining excess energy will be used to charge the battery.</p> <p>When parameter [01]=SUB, PV energy will be prioritized for charging. After meeting the battery's requirements, the remaining energy will be used for load supply, and any further excess energy will be subject to anti-backflow control.</p>
35	Battery Under-voltage Recovery Point	[35] 52.8V Default	When the battery is under-voltage, the battery voltage should be greater than this set value to restore the inverter AC output of the battery. Set range: 48V~58.4V.
37	Battery Recharge Recovery Point	[37] 53.6V Default	After the battery is fully charged, the inverter will stop charging, and when the battery voltage is lower than this Value, the Inverter will resume charging again. Set range: 48V~54V.
38	AC Output Rated Voltage	[38] 230Vac Default	Set range: 200/208/220/230/240Vac
39	Charge current limiting method (when BMS is enabled)	[39] LC SET	Max. battery charging current not greater than the value of setting 【07】 .
		[39] LC BMS Default	Max. battery charging current not greater than the limit value of BMS.
		[39] LC INV	Max. battery charging current not greater than the logic judgements value of the inverter.
40	1-section start charging time	[40] 00:00:00 Default	Set range: 00: 00-23: 59: 00
41	1-section end charging time	[41] 00:00:00 Default	Set range: 00: 00-23: 59: 00
42	2-section start charging time	[42] 00:00:00 Default	Set range: 00: 00-23: 59: 00
43	2-section end charging time	[43] 00:00:00 Default	Set range: 00: 00-23: 59: 00
44	3-section start charging time	[44] 00:00:00 Default	Set range: 00: 00-23: 59: 00
45	3-section end charging time	[45] 00:00:00 Default	Set range: 00: 00-23: 59: 00
46	Sectional charging function	[46] dIS Default	Disable this Function.
		[46] ENA	When the function is enabled, if PV power is insufficient, the mains will charge the battery within the set time period; outside the time period, the mains will not participate in charging.
47	1-section start discharging time	[47] 00:00:00 Default	Set range: 00: 00-23: 59: 00
48	1-section end discharging time	[48] 00:00:00 Default	Set range: 00: 00-23: 59: 00
49	2-section start discharging time	[49] 00:00:00 Default	Set range: 00: 00-23: 59: 00

50	2-section end discharging time	[50] 00:00:00 Default	Set range: 00: 00-23: 59: 00
51	3-section start discharging time	[51] 00:00:00 Default	Set range: 00: 00-23: 59: 00
52	3-section end discharging time	[52] 00:00:00 Default	Set range: 00: 00-23: 59: 00
53	Time-slot discharge function	[53] dIS Default	Disable this Function
		[53] ENA	When the function is enabled, if the PV power is insufficient but the battery has sufficient charge, the battery will participate in discharging to supply the load during the set period. Outside the set period and when mains power is available, the system will switch to mains power to supply the load.
54	Current date setting	[54] 00:00:00 Default	Set range: 00:01: 01-99:12:31
55	Current time setting	[55] 00:00:00 Default	Set range: 00:00: 00-23:59: 59
57	Stop charging current	[57] 2A Default	Charging stops when the default charging current is less than this setting.
58	Discharge alarm SOC setting	[58] 15% Default	SOC alarm when capacity is less than this set value (valid when BMS communication is normal).
59	Cut-off discharge SOC Settings	[59] 5% Default	Stops discharging when the capacity is less than this setting (valid when BMS communication is normal).
60	Cut-off charge SOC Settings	[60] 100% Default	Stops charging when capacity is greater than or equal to this setting. (valid when BMS communication is normal).
61	Switch to mains SOC Settings	[61] 10% Default	Switch to mains when capacity is less than this setting. (valid when BMS communication is normal).
62	Switch to inverter output SOC Settings	[62] 100% Default	Switches to inverter output mode when capacity is greater than or equal to this setting. (valid when BMS communication is normal).
63	N-PE bonding automatic switching function	[63] DIS Default	Disable automatic switching of N-PE connections.
		[63] ENA	Enable automatic switching of N-PE connections.
64	Password input	[64] 00000 Default	When the screen is off, Input the password to set parameters.
65	Password setting	[65] 00000 Default	Set the password
67	Grid-connected power selling power setting	[67] 6000W Default	Total power setting range for electricity sales: 0~6000W
72	Battery grid-connected discharge enable	[72] dIS Default	Battery is not allowed to feed power back to the grid.
		[72] ENA	Battery is allowed to feed power back to the grid.

73	Generator charge current	[73] 100A Default	Setting range: 0~135A
74	Generator power	[74] 6000W Default	Setting range: 0~9000W
76	External CT ratio	[76] 1000 Default	When connecting an external CT, enter the ratio specified on the CT's rating. Setting range: 0~8000.
77	Anti-reverse flow error power	[77] 100W Default	In anti-reverse flow conditions, the error calibration power is used to adjust the inverter's sampling error. The default value is 100W, with a setting range of 0~500W.
78	Battery discharge current during hybrid load	[78] 100A Default	When the battery and grid jointly supply power to the load, the battery discharge current must be set. Setting range: 0~135A
81	Generator port working mode	[81] GEN IN Default	Generator input.
		[81] SMLOAD	Smart Load output.
82	CT direction enable	[82] NO CT Default	No CT input.
		[82] TO INV	CT direction set to inverter flow as positive direction.
		[82] TO GRd	CT direction set to grid flow as positive direction.
83	Electric meter options	[83] dIS Default	No electric meter.
		[83] ONE	Select single-phase meter.
85	Electric meter address	[85] 2 Default	Setting range: 1~254
86	Off-grid disconnect smart load	[86] dIS Default	When this option is enabled, smart loads will disconnect when the system switches to off-grid mode. Otherwise, the system will continue to supply power to smart loads while in off-grid mode.
		[86] ENA	
87	Mains power is always connected to the smart load	[87] dIS Default	When this option is enabled, the grid will continuously supply power to smart loads. Otherwise, smart loads will disconnect when the battery cannot meet power demands.
		[87] ENA	
88	Disable smart load SOC	[88] 10% Default	When the battery SOC is lower than this setting, the smart load will disconnect. Valid during BMS communication. Setting range: 0~50%.
89	Disable smart smart load voltage point	[89] 46V Default	When the battery voltage is lower than this setting, the smart load will disconnect. Valid when there is no BMS communication. Setting range: 40~54V.
90	Restore smart load SOC	[90] 100% Default	When the battery SOC is higher than this setting, the smart load will connect. Valid during BMS communication. Setting range: 55~100%.
91	Restore smart load voltage point	[91] 56V Default	When the battery voltage is higher than this setting, the smart load will connect. Valid when there is no BMS communication. Setting range: 48V~60V.

92	Stop charging SOC within charging period	[92] 100% Default	The battery charge cut-off SOC during the scheduled charging period (effective during BMS communication). Setting range: 55%~100%.
93	Stop charging voltage within charging period	[93] 57.6V Default	The battery charge cut-off voltage during the scheduled charging period (effective during BMS communication). Setting range: 48V~59.2V.
94	Max. charging power within charging period	[94] 6000W Default	During the scheduled charging period, the battery charging power. Setting range: 0~6000W.
95	Charging source selection during the charging period	[95] ALL Default	During the charging period, the generator and mains power serve as charging sources; both the generator and mains power can be used for charging.
		[95] Grid	During the charging period, the mains power serves as the charging source; only the mains power can be used for charging.
		[95] Gen	During the charging period, the generator serves as the charging source; only the generator can be used for charging.
96	Stop discharge SOC during the discharge period	[96] 10% Default	Battery discharge cut-off SOC during the scheduled discharge period (effective during BMS communication). Setting range: 0~50%.
97	Stop discharge voltage during the discharge period	[97] 42V Default	Battery discharge cut-off voltage during the scheduled discharge period (effective during BMS communication). Setting range: 42V~59.2V.
98	Max. discharge power during the discharge period	[98] 6000W Default	Battery discharge power during the scheduled discharge period. Setting range: 0~6000W.
99	Generator peak shaving function	[99] dIS Default	When the generator input power exceeds the rated capacity, the system will automatically activate the inverter to supplement the insufficient power (via PV/battery), effectively reducing the dynamic load pressure on the generator, avoiding the risk of generator overload, and ensuring stable and reliable power supply.
		[99] ENA	
100 (A0)	BuckUp Delay	[A0] 0ms Default	When the grid is powered off, the inverter will automatically start power output after a set time (0-30000ms).

5.3 AC Output Mode

The AC output mode corresponds to parameter setting item 01 and 34, which allows the user to set the AC output power source manually.

■ Utility Priority Output 01 UTI

Utility priority for power supply. It will only switch to the inverter when the grid power is cut off. **(Priority: PV > Utility > Battery)**

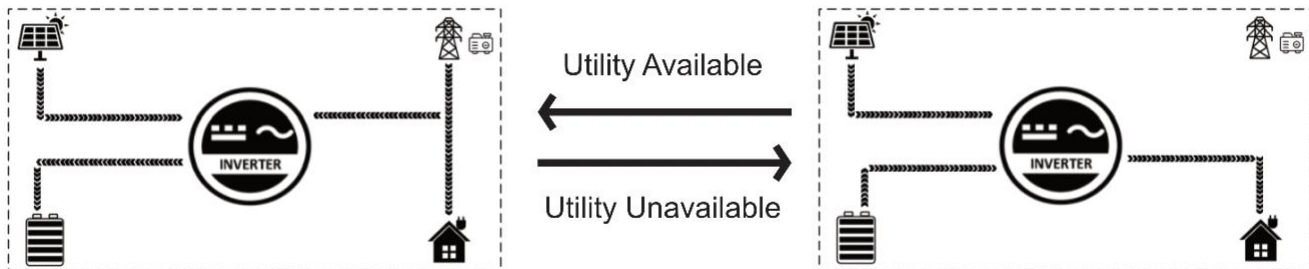

■ PV and Utility hybrid loading 01 SUB (default)

PV priority charging; When PV power is insufficient, utility power and PV will perform hybrid charging (when item 06 is set to "PV-only charging", utility power will not be used for charging), and utility power will supply the load. When PV power meets the charging demand but cannot meet the load demand, PV and utility power will perform hybrid loading, and the battery will only discharge in off-grid mode.

(Priority: Utility > PV > Battery)

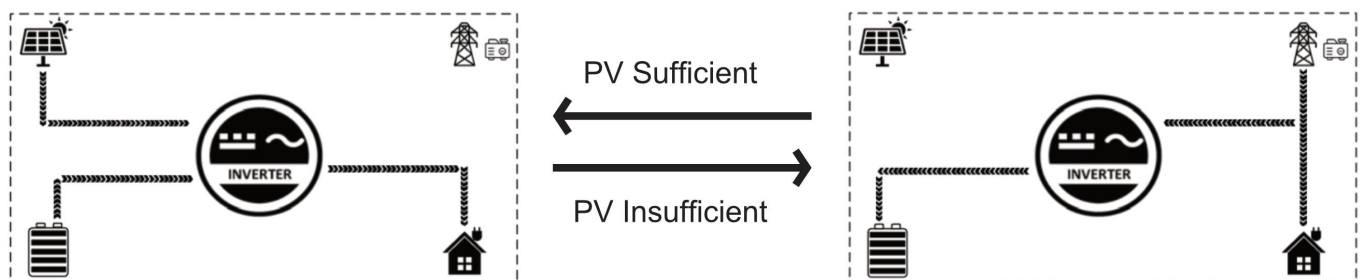

■ PV Priority Output 01 SOL

PV prioritizes power supply to the load. When PV meets the load demand, the excess power will charge the battery. When PV energy is insufficient, the battery will supplement energy to power the load. When PV is invalid, it will switch to utility power supply, and finally use battery power supply. When PV energy is insufficient, and when the battery level is lower than the parameter (Battery to utility) or the SOC setting value for switching to utility, it will switch to utility power supply for the load and charging. PV charges when there is no load. This mode can maximize the use of PV power generation while maintaining battery capacity, and is suitable for areas with stable power grids.

(Priority: PV > Utility > Battery)

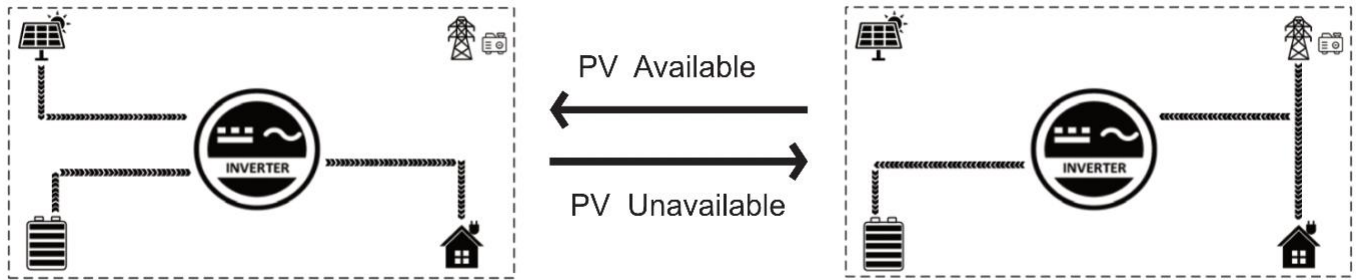

■ Inverter Priority Output 01 SBU

The PV will supply power to the loads on a priority basis. If the PV is insufficient or unavailable, the battery will be used as a supplement to supply power to the load. When the battery voltage touches the value of parameter [04] (Voltage point of battery switch to utility), it will switch to utility power supply to the load (without BMS connected) / When the BMS is connected and the Li-ion battery SOC touches the value of parameter [61] (Switching to utility SOC setting), it will switch to utility power supply to the load. This mode maximises the use of DC energy, and it is suitable for the areas where the utility power is stable.

(Priority: PV > Battery > Utility)

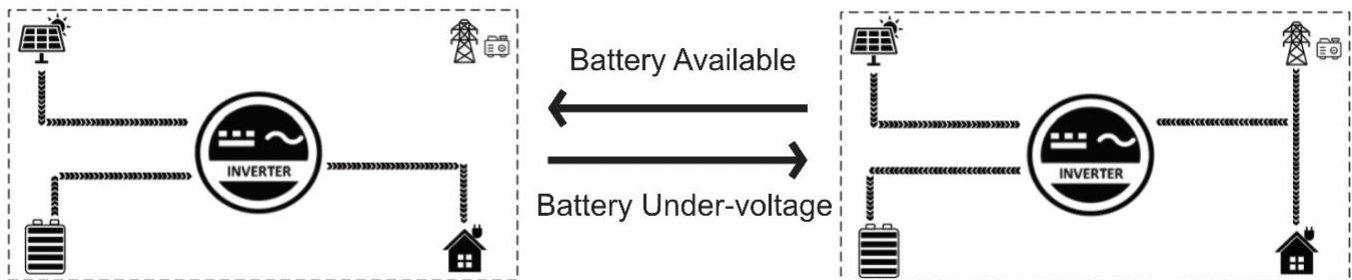

5.4 Battery Charging Mode

The charging mode corresponds to parameter [06], which allows the user to set the charging mode manually.

■ Hybrid Charging SNU (default)

PV and utility power charge the battery at the same time, with PV taking priority and mains power acting as a supplement when PV is insufficient. This is the fastest charging method and is suitable for areas with insufficient power supply, providing sufficient backup power for users. **(Priority: PV > Utility)**

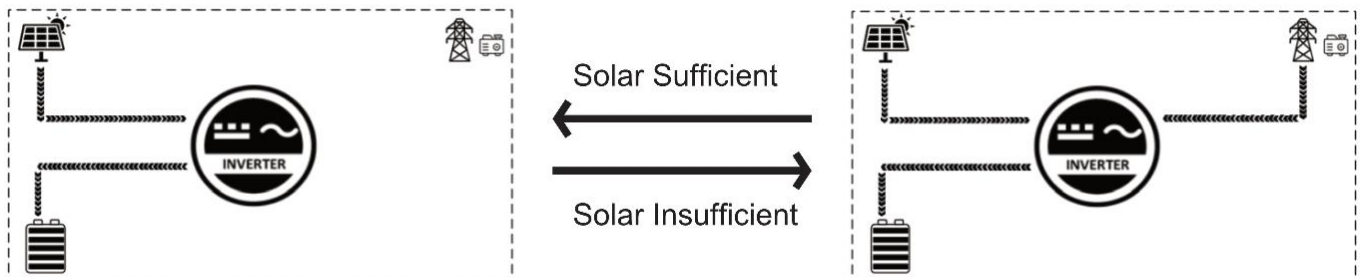

■ Only PV Charging OSO

Only PV power is used to charge the battery, without starting the utility charging. This is the most energy-efficient method, with all battery power coming from solar energy, and is usually used in areas with good radiation conditions.

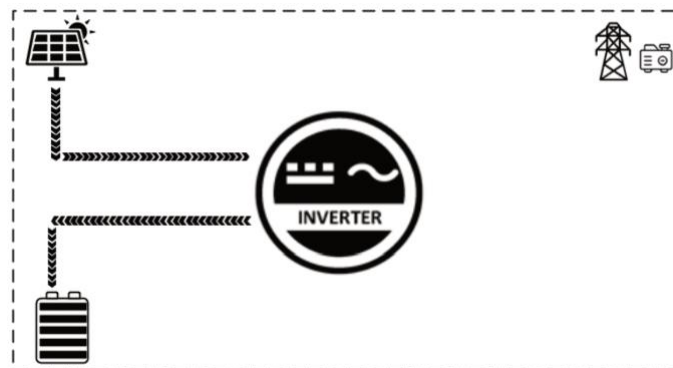



5.5 Time-slot Charging and Discharging Function

The HESP series is equipped with time-of-use charging and discharging functions, allowing users to set different charging and discharging periods according to the local peak-valley electricity prices, thereby making rational use of municipal electricity and photovoltaic power. When the price of municipal electricity is high, the battery inverter is used to power the loads; when the price of municipal electricity is low, the municipal electricity is used to power the loads and charge the battery. This helps users save electricity costs to the greatest extent.

The following examples are provided to help users understand its functions.

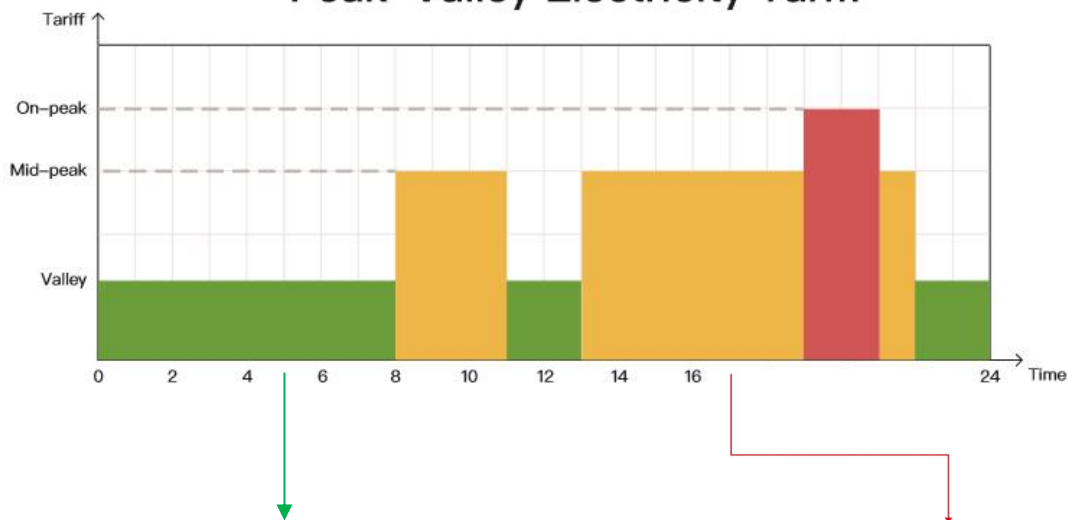
Peak-Valley Electricity Tariff



Time-slot Utility Charging & Loading Function	Time-slot Battery Discharging Function
	
<p>With 3 definable periods, the user can freely set the mains charging/supplying power time within the range of 00:00 to 23:59. During the time period set by the user, if PV energy is available, PV energy will be used first, and if PV energy is not available or insufficient, utility energy will be used as a supplement.</p>	<p>With 3 definable time periods, users can freely set the battery discharge time within the range of 00:00 to 23:59. During the time set by the user, the inverter will give priority to the battery inverter to carry the load, and if the battery power is insufficient, the inverter will automatically switch to mains power to ensure stable operation of the load.</p>

5.6 Battery Parameters

5.6.1 Lead-Acid Battery

Battery type Parameters	Sealed lead acid battery (SLD)	Gel lead acid battery (GEL)	Flooded lead acid battery (FLD)	User-defined (USE)	Adjustable
Overvoltage Disconnect Voltage	60V	60V	60V	60V	
Battery fully charged recovery point	52V	52V	52V	52V	√
Boost Charging Voltage	57.6V	57.6V	57.6V	40 ~ 60V	√
Undervoltage Alarm Voltage	44V	44V	44V	40 ~ 60V	√
Undervoltage Alarm Recovery Voltage	Undervoltage alarm voltage+0.8V				
Low Voltage Disconnect Voltage	42V	42V	42V	40 ~ 60V	√
Low Voltage Disconnect Recovery Voltage	52V	52V	52V	52V	√
Discharge Limit Voltage	-	-	-	40 ~ 60V	√
Over-discharge Delay Time	5s	5s	5s	1 ~ 30s	√
Boost Charge Duration	-	-	-	10 ~ 600min	√

5.6.2 Lithium-ion Battery

Battery type Parameters	Ternary (N13)	Ternary (N14)	LFP (L16)	LFP (L15)	LFP (L14)	Adjustable
Overvoltage Disconnect Voltage	60V	60V	60V	60V	60V	
Battery Fully Charged Recovery Point	50.4V	54.8V	53.6V	50.4V	47.6V	√
Equalization Charging Voltage	-	-	-	-	-	√
Boost Charging Voltage	53.2V	57.6V	56.8V	53.2V	49.2V	√
Undervoltage Alarm Voltage (Fault 01)	43.6V	46.8V	49.6V	46.4V	43.2V	√
Undervoltage Alarm Recovery Voltage(Fault 01)	Undervoltage alarm voltage+0.8V					
Low Voltage Disconnect Voltage(Fault 04)	38.8V	42V	48.8V	45.6V	42V	√
Low Voltage Disconnect Recovery Voltage(Fault 04)	46V	49.6V	52.8V	49.6V	46V	√
Discharge Limit Voltage	36.4V	39.2V	46.4V	43.6V	40.8V	√
Over-discharge Delay Time	30s	30s	30s	30s	30s	√
Boost Charge Duration	120min	120min	120min	120min	120min	√

6. Communication

6.1 Product Overview

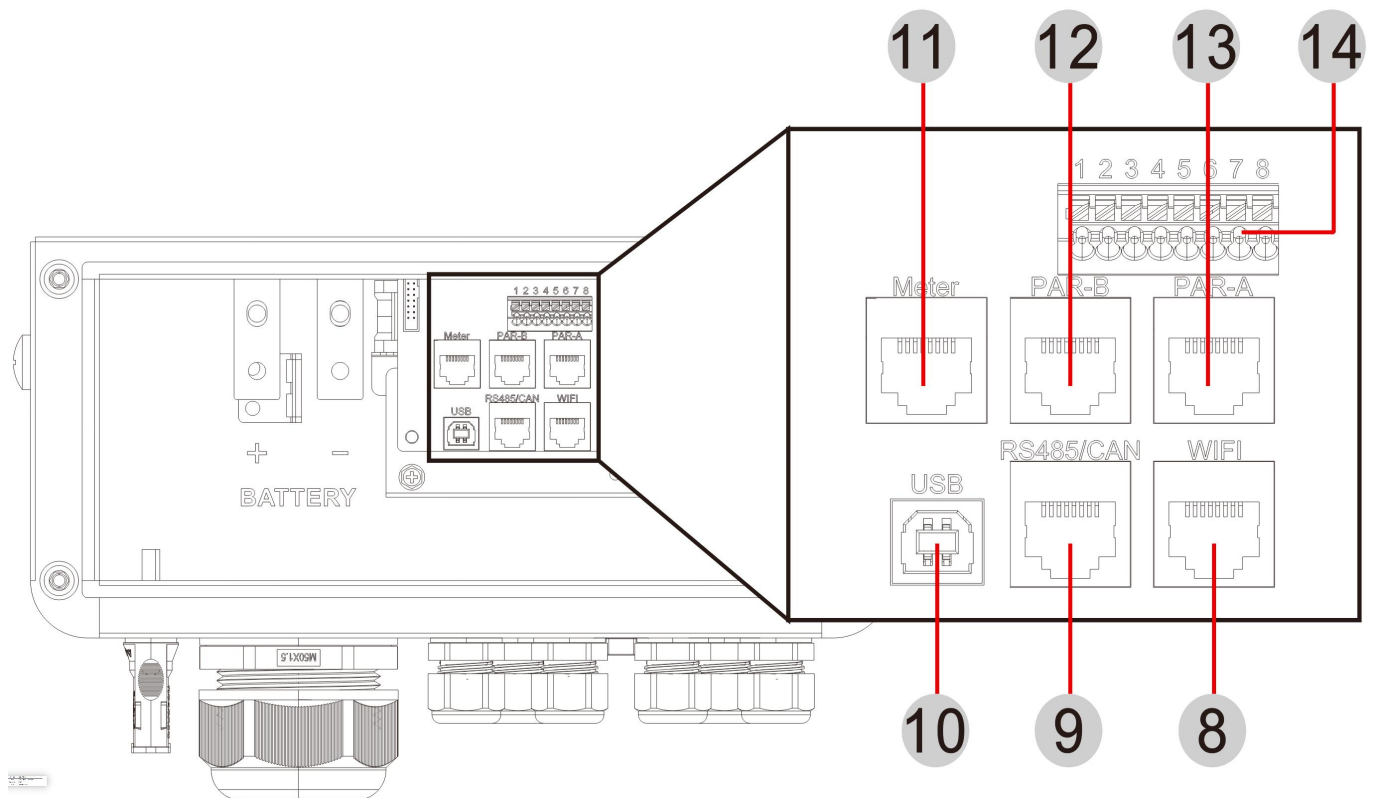

8	WiFi Port	9	RS485/CAN Port	10	USB Port
11	Meter Port	12	Parallel B	13	Parallel A
14	Dry contact				

6.2 RS485/CAN Communication Function

- 1.The RS485/CAN communication port supports RS485 protocol communication with lithium battery BMS systems.
- 2.The RS485/CAN communication port supports CAN protocol communication with lithium battery BMS systems.

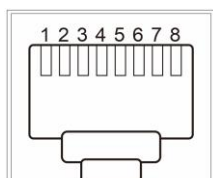

RS485/CAN

RJ45	Pin 1	Pin 2	Pin 3	Pin 4	Pin 5	Pin 6	Pin 7	Pin 8
Description	RS485-B	RS485-A	/	CANH	CANL	/	RS485-A	RS485-B

NOTICE

If you need to use the inverter to communicate with the lithium battery BMS, please contact us for the communication protocol or upgrade the inverter to the appropriate software programme.

6.3 WiFi Communication (Optional)

The WiFi communication port can be connected to the optional RS485-to-WIFI/GPRS communication module developed by our company. After installing this module, it can connect to our inverter, allowing users to view the inverter's operating status and parameters through a mobile APP.

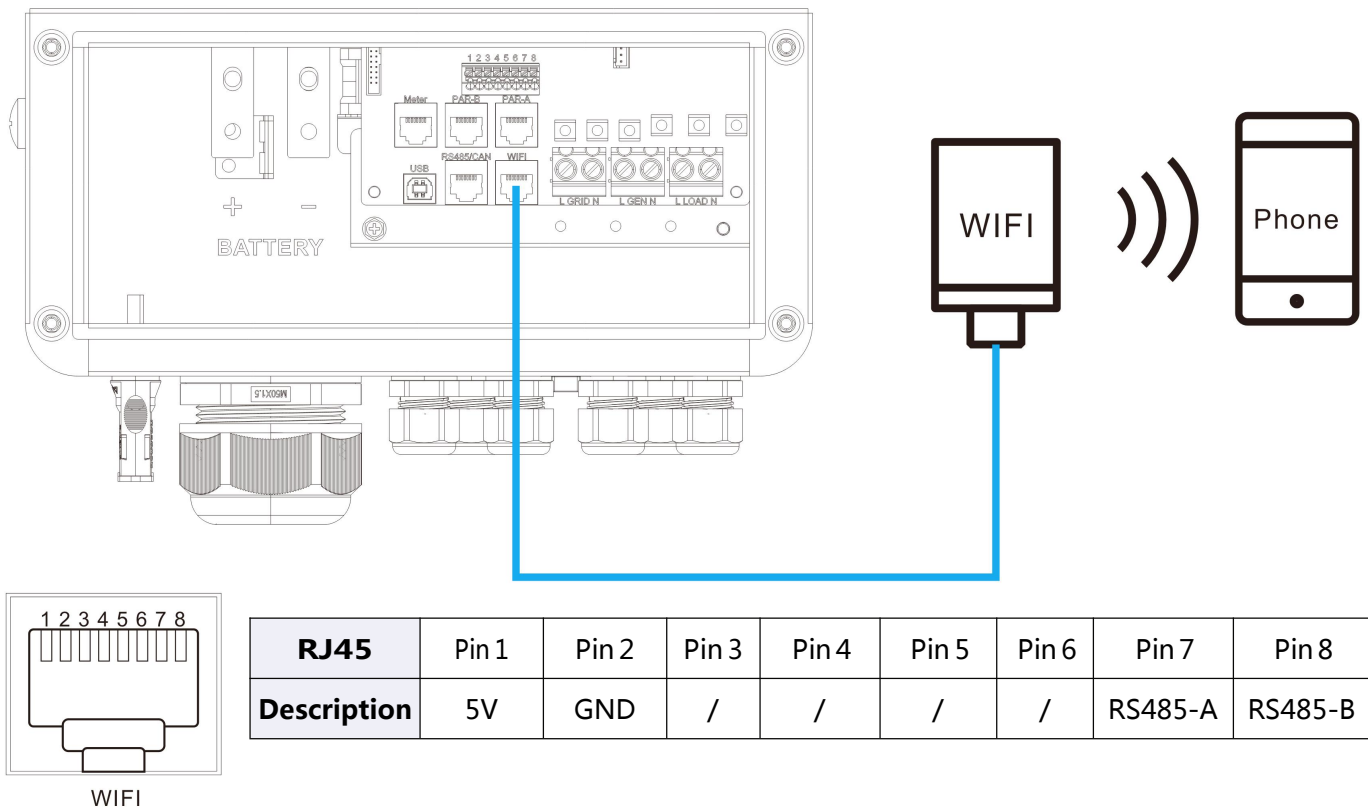

6.4 USB Communication Function

This port is a USB communication port, which can be used for USB communication with our optional upper computer software (application required) via this port. To use this port, the corresponding "USB-to-serial port chip CH340T driver" must be installed on the computer.

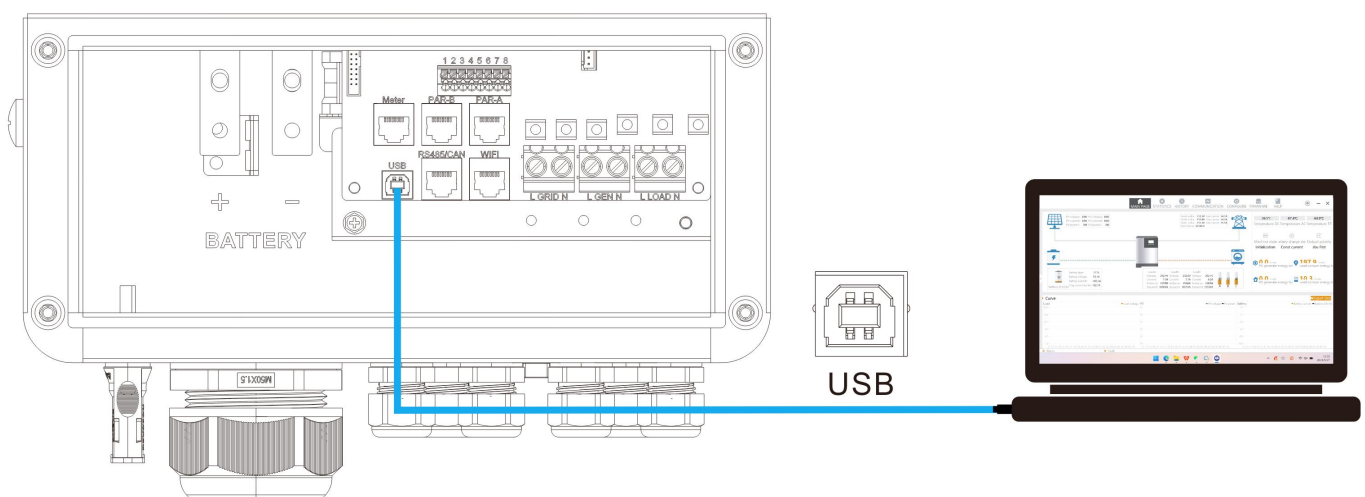

6.5 Meter Communication (Optional)

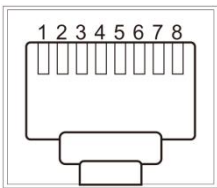
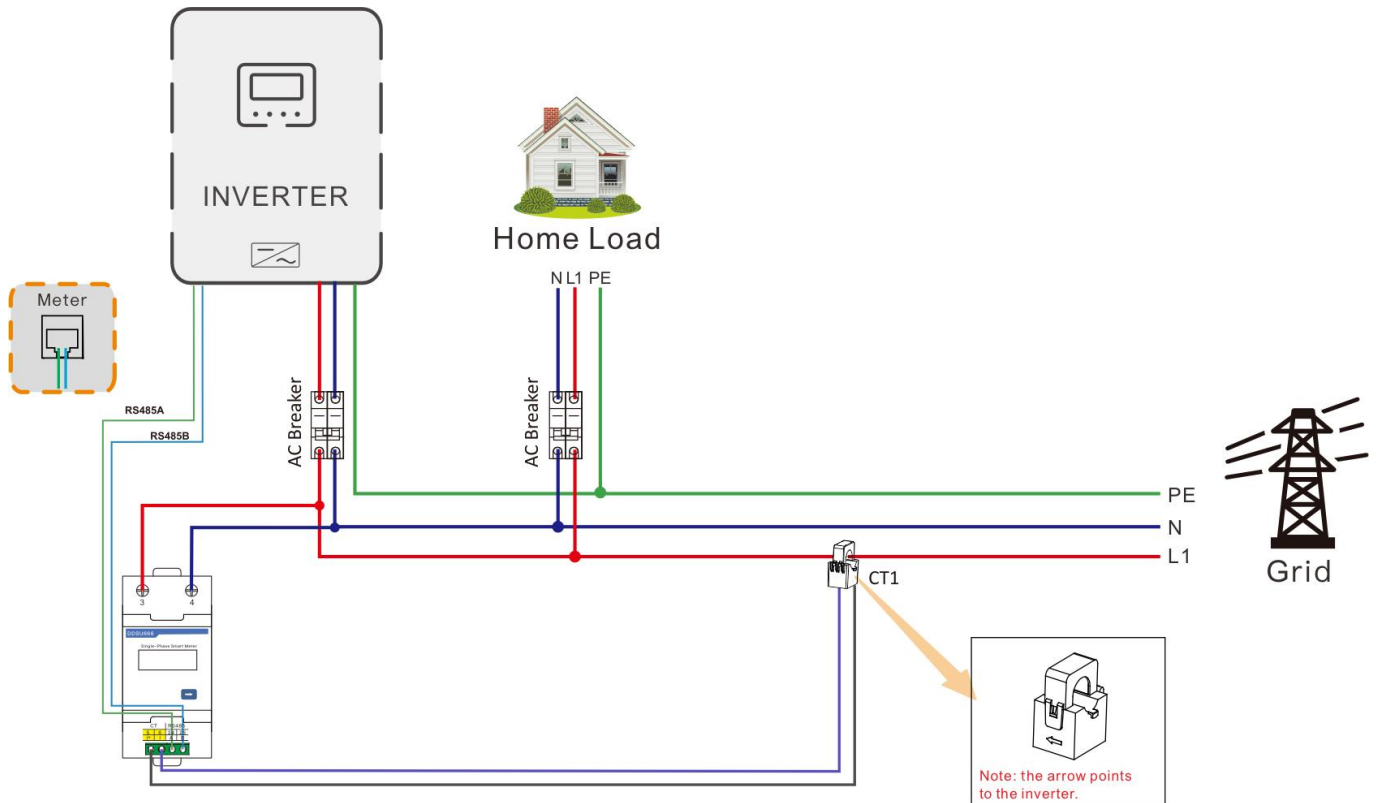

Meter

RJ45	Pin 1	Pin 2	Pin 3	Pin 4	Pin 5	Pin 6	Pin 7	Pin 8
Description	RS485-B	RS485-A	/	/	/	/	RS485-A	RS485-B

1. Meter size: (mm)
2. Smart Meter size 1: (mm)

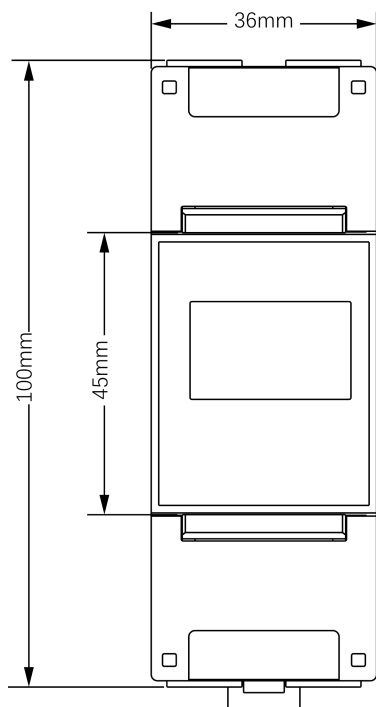

6.6 Parallel Communication Function

This port is a parallel communication port, through which parallel modules can communicate with each other when connected.

1. Each device is equipped with two 8-pin parallel communication ports: PAR-A (Parallel Port A) and PAR-B (Parallel Port B).
2. For connection, connect the PAR-A (Parallel Port A) of the current device to the Parallel Port B of the device to be paralleled, or connect the PAR-B (Parallel Port B) of the current device to the Parallel Port A of the device to be paralleled.
3. Direct connection between the PAR-A and PAR-B of the same device is prohibited.

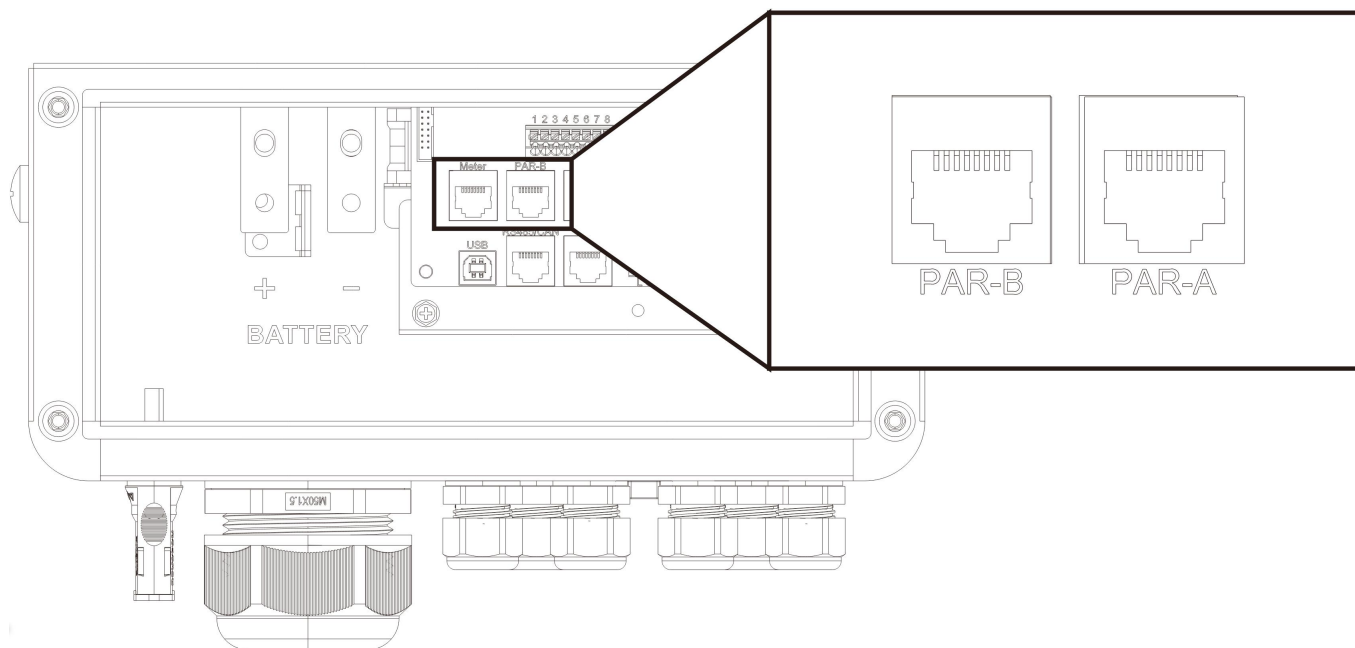

6.7 Dry Contact Function

The dry contact port has 3 functions :

1. RSD power supply
2. Temperature sampling (reserved)
3. Remote generator start/stop

Function	Description
RSD power supply	PIN 1 is GND , PIN 2 is RSD 12V+
Temperature sampling (reserved)	Pin 1 & Pin 2 can be used for battery temperature sampling compensation.
Remote generator start/stop	When the generator is connected, the following conditions must be met: Remote start the generator when there is no grid connection; When there is no BMS connection, remote start the generator if the battery voltage is lower than the undervoltage alarm voltage or the battery switches to the grid voltage point; When BMS is connected, remote start the generator if the battery SOC is lower than the set value of the battery-to-mains SOC switching point; When there is no BMS connection, remote stop the generator if the battery

	<p>voltage reaches the mains-to-battery switch voltage point or the battery is fully charged;</p> <p>When BMS is connected, remote stop the generator if the battery SOC is lower than the set value of the mains-to-battery SOC;</p> <p>Remote shut down the generator when the battery is fully charged;</p> <p>Remote generator start: Pin 6 to Pin 7 (normally open), Pin 6 to Pin 8 (normally closed).</p> <p>Remote generator stop: Pin 6 to Pin 7 (normally closed), Pin 6 to Pin 8 (normally open).</p> <p>(The allowable voltage and current ranges for Pins 6/7/8 are 100Vac/1A, 200Vac/1A, and 30Vdc/1A respectively.)</p>
External CT	<p>Pin 7: CT-</p> <p>Pin 8: CT+</p>

NOTICE

If you need to use the remote start/stop function of a dry contact generator, please ensure that the generator is equipped with an automatic transmitter and supports remote start/stop functions.

6.8 External CT Communication (Optional)

- 1.Current Transformer (CT) Dimensions: (mm)
- 2.Length of Secondary Output Cable: 4m
- 3.CT Direction Points to the Inverter

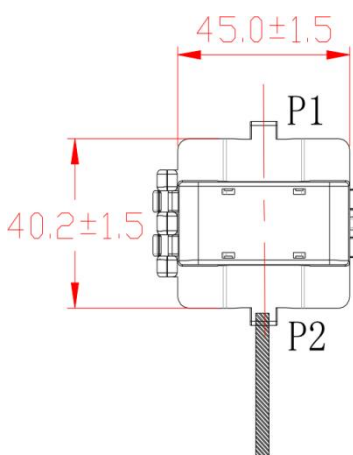
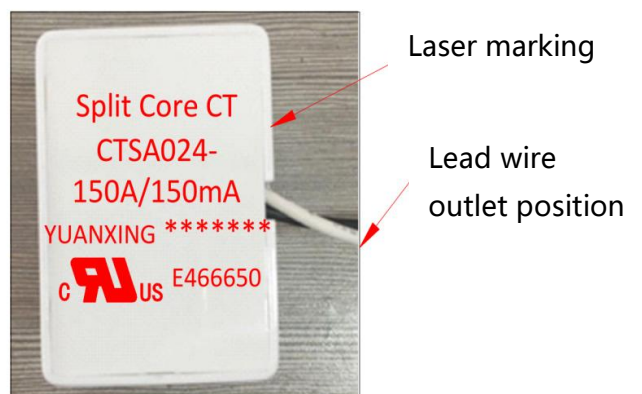
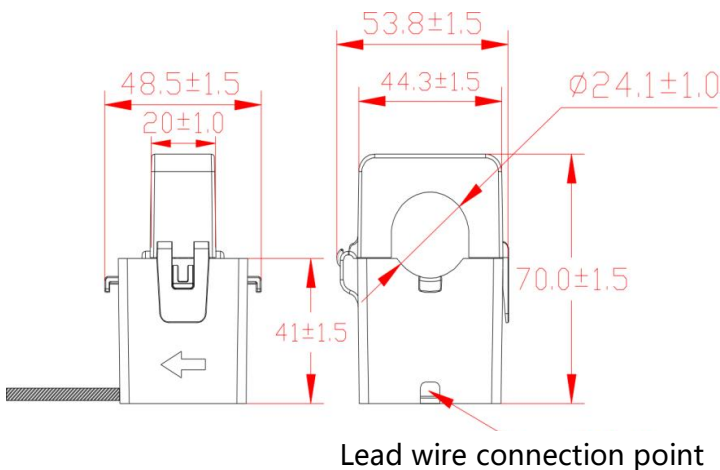

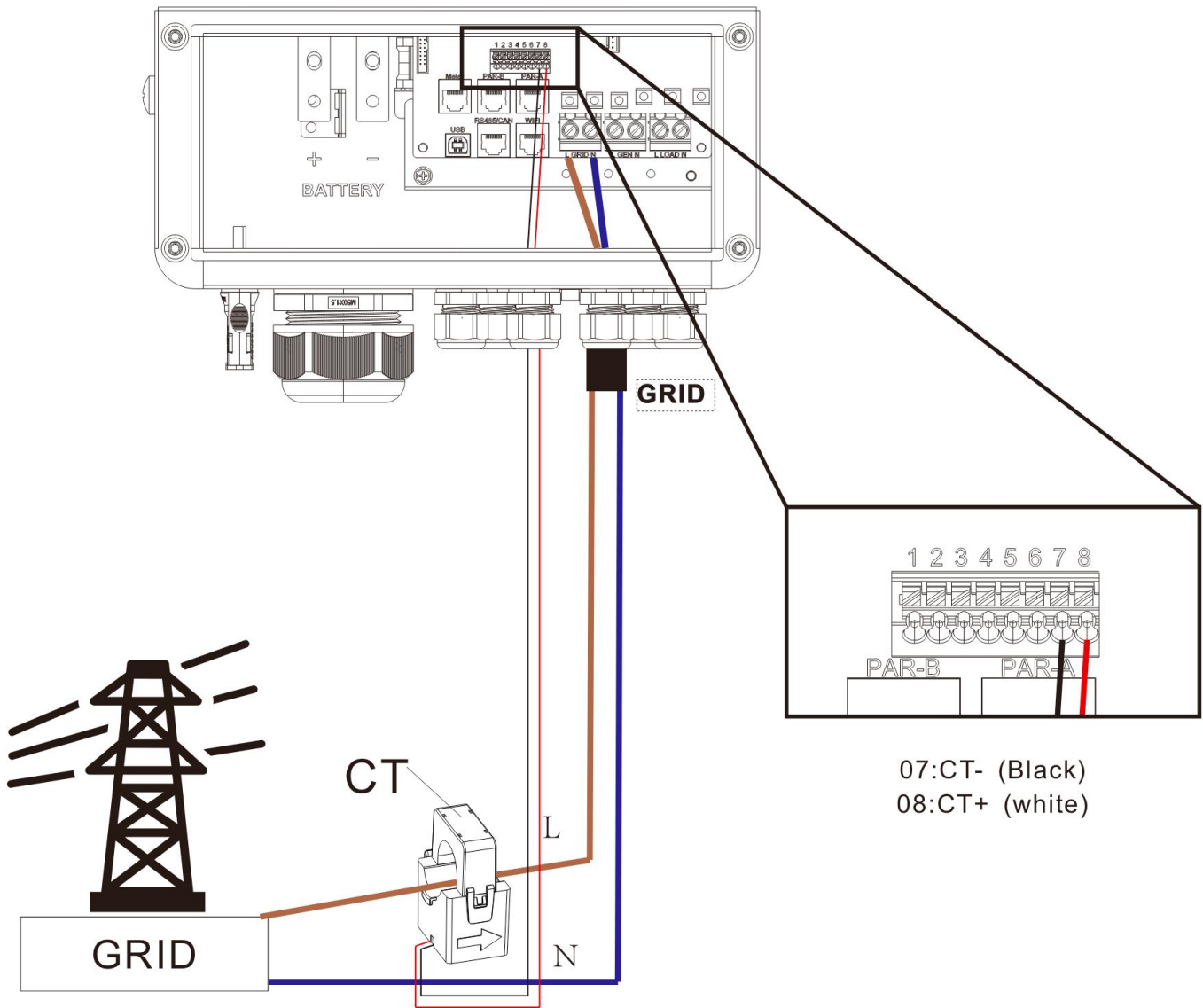

6.9 DIP Switch Configuration



This DIP switch is a resistor matching switch for parallel communication. When performing parallel CAN communication, the first and last units in the parallel system must have DIP switches 1 and 2 toggled down.

7. Fault Codes and Countermeasures

7.1 Fault Codes

Fault Code	Meaning	Impact on Output	Description
01	BatVoltLow	NO	Battery undervoltage alarm.
02	BatOverCurrSw	YES	Battery discharge average current overcurrent (software protection).
03	BatOpen	YES	Battery not-connected alarm.
04	BatLowEod	YES	Battery undervoltage stop discharge alarm.
05	BatOverCurrHw	YES	Battery overcurrent (hardware protection).
06	BatOverVolt	YES	Charging overvoltage protection.
07	BusOverVoltHw	YES	Bus overvoltage (hardware protection).
08	BusOverVoltSw	YES	Bus overvoltage (software protection).
09	PvVoltHigh	NO	PV overvoltage protection.
10	PvAFCIErr	NO	PV Arc Fault.
11	PvBoostOCHw	NO	Boost overcurrent (hardware protection).
13	OverloadBypass	YES	Bypass overload protection.
14	OverloadInverter	YES	Inverter overload protection.
17	InvShort	YES	Inverter short-circuit protection.
19	OverTemperMppt	NO	PV radiator over-temperature protection.
20	OverTemperInv	YES	Inverter radiator over-temperature protection.
21	FanFail	YES	Fan fault.
22	EEPROM	YES	Memory fault.
23	ModelNumErr	YES	Model setting error.
26	Rlyshort	YES	Inverter AC Output Backfeeding to Bypass AC Output.
29	BusVoltLow	YES	Bus voltage undervoltage protection.
30	BatCapacityLow1	NO	Alarm when the battery capacity rate is below 10% (BMS enable validity setting required).
31	BatCapacityLow2	NO	Alarm when the battery capacity rate is below 5% (BMS enable validity setting required).
32	BatCapacityLowStop	YES	Battery low-capacity shutdown (BMS enable must be set valid).
34	CanCommFault	YES	Parallel CAN communication failure.
35	ParaAddrErr	YES	Parallel machine ID (communication address) setting error.
37	ParaShareCurrErr	YES	Parallel current sharing failure.
38	ParaBattVoltDiff	YES	Parallel mode, large battery voltage difference.

39	ParaAcSrcDiff	YES	Parallel mode, inconsistent mains input sources.
40	ParaHwSynErr	YES	Parallel mode, hardware synchronization signal failure.
41	InvDcVoltErr	YES	Abnormal DC component of inverter voltage.
42	SysFwVersionDiff	YES	Inconsistent parallel machine program versions.
43	ParaLineContErr	YES	Parallel wiring failure.
44	Serial number error	YES	Factory-set serial number not configured.
45	Error setting of split-phase mode	YES	Incorrect setting of parallel mode parameters.
58	BMSComErr	NO	BMS communication failure.
59	BMS Alarm	NO	After reviewing the lithium battery BMS fault types, clear the lithium battery faults.
60	BMSUnderTem	NO	BMS low-temperature alarm (takes effect after successful BMS communication).
61	BMSOverTem	YES	BMS over-temperature alarm (takes effect after successful BMS communication).
62	BMSOverCur	YES	BMS over-current alarm (takes effect after successful BMS communication).
63	BMSUnderVolt	NO	BMS under-voltage alarm (takes effect after successful BMS communication).
64	BMS Battery Overvoltage Alarm	NO	Lithium Battery BMS Overvoltage Alarm

7.2 Partial Troubleshooting

Fault Code	Meaning	Cause
Display	No display on the screen	Check if the battery switch or PV switch is closed; whether the switch is in the "ON" state; press any button on the screen to exit the screen sleep mode.
[06]	Battery overvoltage protection	Check that the battery voltage does not exceed the protection value. If it does, discharge the battery until the voltage falls below the battery over-voltage recovery point.
[01] [04]	Battery undervoltage protection	Charge the battery until it returns to the low voltage disconnection recovery voltage.
[21]	Fan failure	Check if the fan is not turning or blocked by foreign object.
[19] [20]	Heat sink over temperature protection	When the temperature of the device is cooled below the recovery temperature, normal charge and discharge control is resumed.

[13] [14]	Bypass overload protection, inverter overload protection	1.Reduce electrical equipment; 2.Restart the all-in-one machine, and the load will resume output. 3.Carefully check the load connection and remove the short-circuit
[17]	Inverter short-circuit protection	fault point; 4.Power on again, and the load will resume output.
[09]	PV overvoltage	Use a multimeter to check if the PV input voltage exceeds the maximum allowable input voltage rated.
[03]	Battery disconnection alarm	
[40] [43]	Parallel connection fault	Check if the battery is not connected or if the battery circuit breaker is not closed.
[35]	Parallel ID setting error	Check whether the setting of parallel ID number is repeated.
[37]	Parallel current sharing fault	Check if the parallel current sharing line is not connected well, such as loose or wrong connection.
[39]	Parallel Mode, Grid input source inconsistent	Check whether the parallel AC inputs are from the same input interface.
[42]	Inconsistent system firmware version in parallel mode	Check whether the software version of each inverter is consistent.
[44]	Serial number error	Incorrect device serial number setting.
[45]	Parallel mode error	There is a device in the parallel system with the wrong parallel mode setting.

 **NOTICE**

If you encounter a fault with the product that cannot be solved by the methods in the table above, please contact our after-sales service for technical support and do not disassemble the equipment yourself.

8. Protection and Maintenance

8.1 Protection Functions

No.	Protection Functions	Definition
1	PV input current/power limiting protection	When the charging current or power of the PV array configured exceeds the PV input rated value, the inverter will limit the input power and charge at the rated.
2	PV input over-voltage	If the PV voltage exceeds the maximum value allowed by the hardware, the machine will report a fault and stop the PV boost to output a sinusoidal AC wave.

3	PV night reverse current protection	At night, the battery is prevented from discharging through the PV module because the battery voltage is greater than the voltage of PV module.
4	AC input over-voltage protection	When the mains voltage exceeds 280Vac, mains charging will stop and the inverter will switch to output mode.
5	AC input under-voltage protection	When the mains voltage falls below 170Vac, mains charging will stop and the inverter will switch to output mode.
6	Battery over-voltage protection	When the battery voltage reaches the over-voltage cut-off point, the PV and the utility will automatically stop charging to prevent the battery from being overcharged and damaged.
7	Battery under-voltage protection	When the battery voltage reaches the under-voltage cut-off point, the inverter will automatically stop the battery discharge to prevent damage from over-discharging the battery.
8	Battery over-current protection	After a period when the battery current exceeds that allowed by the hardware, the machine will switch off the output and stop discharging the battery.
9	AC output short-circuit protection	When a short-circuit fault occurs at the load output for more than 200ms, the AC output will be immediately turned off, and then manually re-powered on to restore normal output. (Not in the bypass mode)
10	Heat sink over-temperature protection	When the internal temperature of the inverter is too high, the inverter will stop charging and discharging; when the temperature returns to normal, the inverter will resume charging and discharging.
11	Overload Protection	After triggering overload protection, the inverter will resume output after 3 minutes. Five consecutive overloads will shut down the output until the inverter is restarted.
12	PV Anti-Reverse Protection	The machine will not be damaged if the PV polarity is reversed.
13	AC Backfeed Protection	Prevents battery-inverted AC power from backfeeding into the bypass AC input.
15	Bypass Wiring Error Protection	When the phase of the two bypass inputs is different from the phase of the inverter phase split, the machine will prohibit cutting into the bypass to prevent the load from dropping out or shorting out when cutting into the bypass.
16	Short-Circuit Protection During Charging	When the battery's external terminals are short-circuited during photovoltaic or AC charging, the inverter will activate protection and cease outputting current.
17	Parallel Connection Wiring Fault Protection	During parallel operation, the device activates protection when a parallel connection wire is lost.
18	Parallel Battery Voltage Discrepancy Fault Protection	During parallel operation, the device activates protection when battery connections are inconsistent and the detected battery voltage differs significantly from the host unit.
19	Parallel Operation Mains Voltage Difference Protection	During parallel operation, the device will activate protection when AC IN inputs are not consistently connected.

20	Fault Protection for Current Sharing in Parallel Operation	During parallel operation, if improper connection of current-sharing lines or damaged components causes significant variations in load distribution across individual machines, the equipment will activate protective measures during operation.
21	Synchronization Signal Fault Protection	When a fault occurs in the pilot signal between parallel buses and the behavior of each unit becomes inconsistent, the equipment will initiate protection.

8.2 Maintenance

To maintain optimal long-term performance, it is recommended to perform the following inspections twice a year for inverter systems:

1. Ensure that the airflow around the inverter is not blocked and remove any dirt or debris from the radiator.
2. Check that all exposed conductors are not damaged by sunlight, friction with other surrounding objects, dry rot, insect or rodent damage, etc. The conductors need to be repaired or replaced if necessary.
3. Verify that the indications and displays are consistent with the operation of the equipment, note any faults or incorrect displays and take corrective action if necessary.
4. Check all terminals for signs of corrosion, insulation damage, high temperatures or burning/discolouration and tighten terminal screws.
5. Check for dirt, nesting insects and corrosion, clean as required , Clean the insect screen regularly.
6. If the lightning arrester has failed, replace the failed arrester in time to prevent lightning damage to the inverter or other equipment of the user.

 **DANGER**

Make sure that the inverter is disconnected from all power sources and that the capacitors are fully discharged before carrying out any checks or operations to avoid the risk of electric shock.

The Company shall not be liable for damage caused by :

1. Damage caused by improper use or use in a wrong location.
2. Photovoltaic modules with an open circuit voltage exceeding the maximum permissible voltage.
3. Damage caused by the operating temperature exceeding the restricted operating temperature range
4. Dismantling and repair of the inverter by unauthorised persons.
5. Damage caused by force majeure: damage during transport or handling of the inverter.

9. Datasheet

Model	AEP4860S135-H	Settable
AC Output		
Rated Output Power	6000W	
Max. Peak Power	2 times of rated power,10s	
Rated Output Voltage	230Vac (200/208/220/230/240Vac Settable)	√
Rated Output Current	26.1Aac	
Rated Frequency	50Hz / 60Hz	√
Waveform	Pure sine wave	
Switch Time	10ms (Typical)	
THDI	< 3%	
Battery		
Battery Type	Lithium-ion / Lead-acid / User-defined Battery	√
Rated Battery Voltage	48Vdc	
Battery Voltage Range	40-60Vdc	√
Max. Charging / Discharging Current	135A	√
Max. PV Charging Current	135A	√
Max. Grid/Generator Charging Current	135A	√
PV Input		
No. of MPPT Trackers	2	
Max. Access Power	12000W	
Max. PV Input Power	6000W + 6000W	
Max. PV Input Current	22Aac + 22Aac	
Max. Input Short-Circuit Current	33Aac + 33Aac	
Max. Input Voltage	500Vdc / 500Vdc	
PV Start-up Voltage	60Vdc / 60Vdc	
MPPT Operating Voltage Range	65Vdc ~ 450Vdc / 65Vdc ~ 450Vdc	
Grid/Generator Input		
Rated Input Voltage	220Vac / 230Vac	
Input Voltage Range	Grid power (170Vac ~ 280Vac) ±2% Generator power (90Vac ~ 280Vac) ±2%	
Input Frequency Range	50Hz : 47Hz ~ 55Hz, with ±0.3Hz accuracy 60Hz : 57Hz ~ 65Hz, with ±0.3Hz accuracy	
Bypass Overload Current	40Aac	
Efficiency		
MPPT Tracking Efficiency	99.9%	
Max. Efficiency	97.5%	

General Data		
Parallel Capacity	1 ~ 6 Units	
Dimensions (W × H × D)	300 x 460 x 217.5mm	
Weight	17.5kg	
Protection Degree	IP65	
Operating Temperature	-40°C ~ 60°C, 45°C derated	
Noise	<55 dB	
Cooling Method	Heat sink + intelligent air cooling	
Communication		
Built-in Interface	RS485 / CAN / USB / Dry contact	√
External Modules	Wi-Fi (Optional)	√
Certification		
Safety Certification	IEC 62109-1/-2 EN 61000	
RoHS	Yes	

SRNE Solar Co,.Ltd

Mail service@szshuori.com

Web www.srnesolar.com

Address 4-5F,Building13A,Taihua Wutong
Industrial Park ,Gushu Development
Zone , Hangcheng Street,Baoan,
Shenzhen, China PR
